

Instruction Manual

**PMC-2
Positioning
Motor Controller,
SB - motors
and
accessories
V20.XX.XX**

COPYRIGHT

© All rights reserved to ELAU AG also in case of patent right applications.

No part of this publication may be reproduced, photocopied, stored on a retrieval system, or transmitted or translated into another language or computer language without the express written consent of the publisher, ELAU AG.

Disclaimer ELAU AG makes no representations or warranties with respect to the contents or use of this manual or with respect to the PMC-2 and specifically disclaims any express or implied warranties of merchantability or fitness for any particular purpose. Further, ELAU AG, reserves the right to revise the publication and to make change to any and all parts of the PMC-2 instruction manual, at any time, without obligation to notify any person or entity of such revisions or changes.

Trademarks:

IBM PC, XT, AT, PS/2 are registered trademarks of the International Business Machine Corporation.

Microsoft, MS, and MS-DOS are registered trademarks, Windows and Windows 386 are trademarks of the Microsoft Corporation.

Intel is a registered trademark and 80286, 80386, 80486, Pentium are trademarks of the Intel Corporation.

Acrobat® Reader Copyright© 1987-1996 Adobe Systems Incorporated. All rights reserved.
Adobe and Acrobat are trademarks of Adobe Systems Incorporated, which may be registered in certain areas.

All other trademarks mentioned are the exclusive property of their manufacturers.

ELAU AG
Dillberg 12
D-97828 Marktheidenfeld

Tel.: 0 93 91 / 606-0
Fax: 0 93 91 / 606-300

eMail: info@elau.de
Internet: <http://www.elau.de>
Mailbox: 09391 / 185 ISDN und analog

ELAU AG
Technisches Büro Nord
An der Kleimannbrücke 98
D-48157 Münster

Tel.: 02 51/1 41 49-0
Fax: 02 51/1 41 49-20

ELAU Automobil
Antriebstechnik GmbH
Dillberg 11
D-97828 Marktheidenfeld

Tel.: 0 93 91/98 50 - 0
Fax: 0 93 91/98 50 - 10
eMail: elau_auto@t-online.de

ELAU SYSTEMS GmbH
Oswald-Greiner-Str. 5
D-04720 Döbeln

Tel.: 0 34 31/57 44-71+72
Fax: 0 34 31/57 44-73

ELAU SYSTEMS ITALIA S.r.l.
Via Tosarelli 302/A
I-40050 Villanova di Castenaso (BO)

Tel.: 00 39/51/78 18 70
Fax: 00 39/51/78 18 69
eMail: vendita@elau.dsnet.it
Internet:
<http://www.affari.com/elau.it/>

Table of contents

1	WHAT IS THE PURPOSE OF THIS INSTRUCTION MANUAL?	5
2	THE PMC-2 IN AN OVERVIEW	6
2.1	INTRODUCTION	6
2.2	APPLICATION RANGE	7
2.3	PERFORMANCE FEATURES	7
2.4	COMMUNICATION	8
2.5	OPERATION WITH BE-7	8
2.5.1	<i>Menu selection</i>	9
2.5.2	<i>Key input</i>	10
2.5.3	<i>Status information</i>	11
2.5.4	<i>Variable and parameter menu</i>	12
2.5.5	<i>I/Os and flags</i>	13
2.5.6	<i>Reset keys</i>	13
2.6	OPERATING UNIT BE-8	14
2.6.1	<i>Mechanics</i>	14
2.6.2	<i>Initial operation</i>	15
2.6.3	<i>Variable menu</i>	16
2.7	PROGRAMMING	18
2.8	MOTORS	19
3	SAFETY	20
3.1	SYMBOL AND NOTE EXPLANATIONS	20
3.2	SAFETY INFORMATION	20
3.3	GENERAL SAFETY INSTRUCTIONS:	21
3.4	ASSEMBLY AND HANDLING	22
3.5	SAFELY SEPARATED EXTRA-LOW VOLTAGES	22
3.6	PROTECTION AGAINST TOUCHING ELECTRICAL PARTS	22
3.7	PROTECTION OF DANGEROUS MOVEMENTS	23
4	INSTALLATION NOTES	24
4.1	PROTECTION METHOD	24
4.2	ESD PROTECTIVE MEASURES	24
4.3	MOUNTING	25
4.4	WIRING NOTES	29
4.4.1	<i>General</i>	29
4.4.2	<i>Electromagnetic Tolerance</i>	30
4.4.3	<i>Mains</i>	33
4.4.4	<i>DC-circuit</i>	35
5	INTERFACES	40
5.1	OVERVIEW	40
5.2	X1 AND X2 POWER PARTS	41
5.3	X4 INPUTS AND OUTPUTS OF THE POSITIONING LEVEL	42
5.4	X5 INPUTS AND OUTPUTS OF THE MOTOR CONTROLLER	43
5.5	X6 RESOLVER	44
5.6	X7 COM1 AND X8 COM2	44
5.7	INTERFACES OF THE ADDITIONAL CARDS	45
5.7.1	<i>X12 encoder</i>	46
5.7.2	<i>X14 Analog I/O module</i>	51
5.7.3	<i>Other option modules</i>	51
5.8	MOTOR CONNECTOR SB-056...205	52
5.8.1	<i>Motor</i>	52
5.8.2	<i>Resolver or SINCOS</i>	52
5.8.3	<i>Brake</i>	52

6	WIRING OF THE PMC-2 IN THE SYSTEM.....	54
6.1	MAINS AND MOTOR CONNECTION.....	54
6.2	THE CONTROL CIRCUIT.....	55
7	COMMISSIONING.....	56
7.1	PROCEDURE.....	56
7.2	LIST OF PARAMETER VARIABLES (P).....	58
7.2.1	<i>General parameters.....</i>	58
7.2.2	<i>Positioning control parameters.....</i>	58
7.2.3	<i>Parameter group 2 - speed regulators.....</i>	59
7.2.4	<i>Parameter group 3 - encoder data.....</i>	59
7.2.5	<i>Parameter group 4 - motor data.....</i>	59
7.2.6	<i>Parameter group 5 - setup.....</i>	60
7.2.7	<i>Parameter group 6 - text for operational unit.....</i>	60
7.2.8	<i>Parameter group 7 - communication.....</i>	61
7.3	DIRECT PARAMETER VARIABLES (Y).....	61
8	DIAGNOSIS AND OPERATION.....	62
8.1	IN GENERAL.....	62
8.2	LEDs AND MONITOR OUTPUTS.....	62
8.3	LIST OF ALL ERRORS.....	63
8.4	CHART WITH ERROR REACTIONS.....	65
8.5	VARIABLES.....	66
8.5.1	<i>Access protection.....</i>	66
8.5.2	<i>Variable types.....</i>	66
8.6	SYSTEM VARIABLES (S).....	67
8.6.1	<i>Not wirable logical system variables.....</i>	67
8.6.2	<i>Wirable logical system variables.....</i>	68
8.6.3	<i>System variables group 2.....</i>	68
8.6.4	<i>System variables group 3.....</i>	69
8.6.5	<i>System variables group 4.....</i>	70
8.6.6	<i>System variables group 5.....</i>	71
8.6.7	<i>System variables group 6 - memory module.....</i>	71
8.6.8	<i>System variables group 7 - communication.....</i>	72
8.6.9	<i>System variables group 8 - options.....</i>	72
8.6.10	<i>System variables group 9.....</i>	72
9	MAINTENANCE.....	74
9.1	SPARE PARTS, COMPONENTS.....	74
9.2	REPAIRS.....	75
9.2.1	<i>Service.....</i>	75
9.2.2	<i>Unit exchange.....</i>	76
10	TECHNICAL DATA.....	80
10.1	PMC-2.....	80
10.2	COMBINATIONS PMC-2 AND SB-MOTORS.....	82
11	APPENDIX.....	86
11.1	DECLARATION BY THE MANUFACTURER.....	86
11.2	MODIFICATIONS.....	90

1 What is the purpose of this instruction manual?

Structure and contents of this documentation

This instruction manual contains information about the interfaces of the PMC-2, its operation, the main parameters and a description of available diagnosis messages and system variables.

This instruction is aimed exclusively at technically qualified staff with detailed knowledge in the sector of automation technology, for only qualified staff have the necessary expertise to interpret and implement safety instructions correctly.

For the sake of clarity, the instruction manual does not contain all details on all versions of the PMC-2 and cannot cover any feasible case of installation, operation or maintenance. In case of specific problems not sufficiently explained here, please contact ELAU.

Further Literature:

PMC-2

Product information	
German	
English	
Projecting manual	
German	Art.Nr. 17 13 00 55 - 000
User documentation	
German	Art.Nr. 17 13 00 51
English	Art.Nr. 17 13 00 52
Italian	Art.Nr. 17 13 00 53
Instruction manual PMC-2	
German	Art.Nr. 17 13 00 54 - 000
English	Art.Nr. 17 13 00 54 - 001
Italian	Art.Nr. 17 13 00 54 - 002
French	Art.Nr. 17 13 00 54 - 003
Spanish	Art.Nr. 17 13 00 54 - 004
Instruction manual PMC-2 BASIC Soft	
German	Art.Nr. 17 13 00 56 - 000

Product training

Naturally we also offer you comprehensive training.

It can be carried out in our offices or, on request, at the customer's site.

The training is offered in German, English or French language.

The functions of the PMC-2 are explained to the customer not only in theory, but also in practical exercises.

Further information is available on request.

2 The PMC-2 in an overview

The PMC-2 digital positioning motor controller is the cost optimal and complete solution in future-oriented technology for your positioning and synchro tasks.

2.1 Introduction

Until now a servo positioning has been realized by means of a positioning control and a separate motor controller.

Now there is the PMC-2, where you will find these two components integrated in one single unit.

The advantages of this conception are as follows:

- no difficulties in adapting positioning control <-> motor controller
- deep system view until down to the motor current via system variables
- one software for positioning and synchro procedures
- one interface for setting parameters and programming of both components
- highly flexible process language

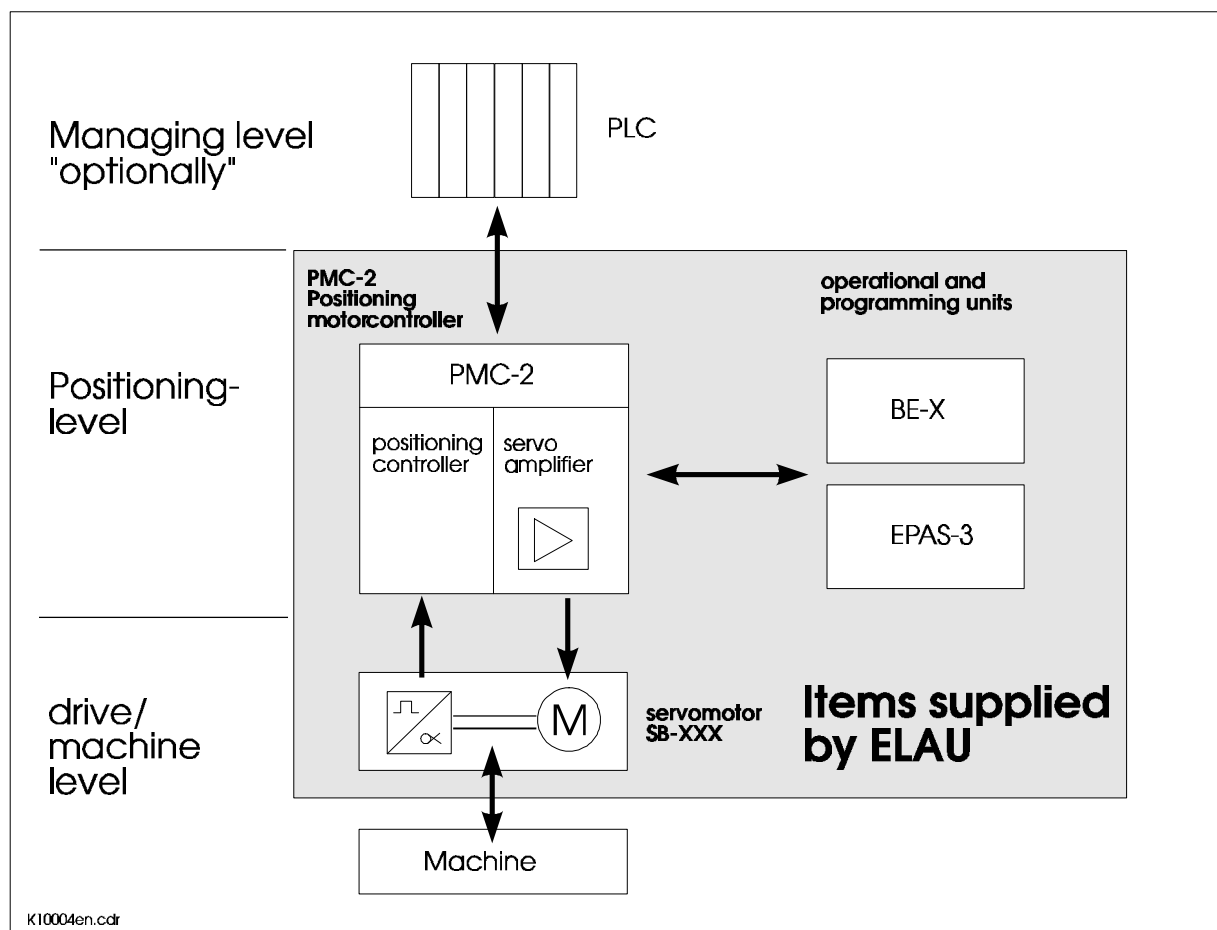

2.2 Application range

All applications requiring a high dynamic, flexible, and precise positioning of brushless AC servo motors.

Typical applications are in tact and angle-synchronous machines:

- food and packaging machines
 - e. g. measurers, foil transport, cut into sections referred to labels, rotating blades
- printing and paper machines
 - e. g. book binding
- textile machines
 - e. g. sewing, weaving, thread transfers
- plastics machines
 - e. g. foil transport, cutting
- hosting engines and mounting techniques
 - e. g. round tables, pallets, feeding, removing
- special purpose machines
 - e. g. flying shear, perforating installations

2.3 Performance features

The PMC-2 positioning motor controller provides the following performance features:

- flexible positioning control and digital motor controller in one case
- direct electric mains with integrated mains filter (600 Volt technology)
- T1-operation according to VDI 2853
- dc-circuits of several PMC-2 are parallelly switchable (power compensation)
- completely digital concept
- multiple processor technology (32 bit processor plus VECON chips)
- one programming interface for POS and MC
- unit exchange without PC (Memory Module)
- highly dynamic brushless AC servo motors SB-056...205 in high-voltage technology with resolver or SINCOS encoder
- extensive cross linkage abilities
- own input and output level (digital and analog I/Os)
- independent operation
- modular extension possibilities via option modules
- connection of absolute or incremental encoders possible
- matured diagnosis
- simple and flexible programming language ECL-3 with multitasking functions
- system variable conception with deep system view until down to the motor current
- realization of positioning and/or synchro functions (electrical gear, disk cam function) with one software
- sampling rate position controller 0,33 ms
- CE in conformity

2.4 Communication

The PMC-2 positioning motor controller communicates:

- with a PLC via inputs/outputs,
- with a PLC via serial data transfer,
- with operational and display units via serial data transfer
- with the Industrial I/O-Lightbus over option module
- with the INTERBUS-S (Remote bus) over option module
- with the PROFIBUS-DP

2.5 Operation with BE-7



The PMC-2 can optionally be equipped with the BE-7 operational unit. Only dock the BE-7 via a d-sub connector. You need the BE-7 for commissioning if you do not have a PC with EPAS-3 or in diagnosis cases. German, English, French, Italian and Spanish texts facilitate the dialogue with the PMC-2.

Access protection

The conception of the PMC-2 includes an access protection mechanism. Parameters and variables are divided in several access authorisation levels for writing and reading.

Performance features of the BE-7:

- parameter editor
 - parameters
 - direct parameters
- variable editor
 - inputs
 - outputs
 - flags
 - user variables
 - system variables

2.5.1 Menu selection

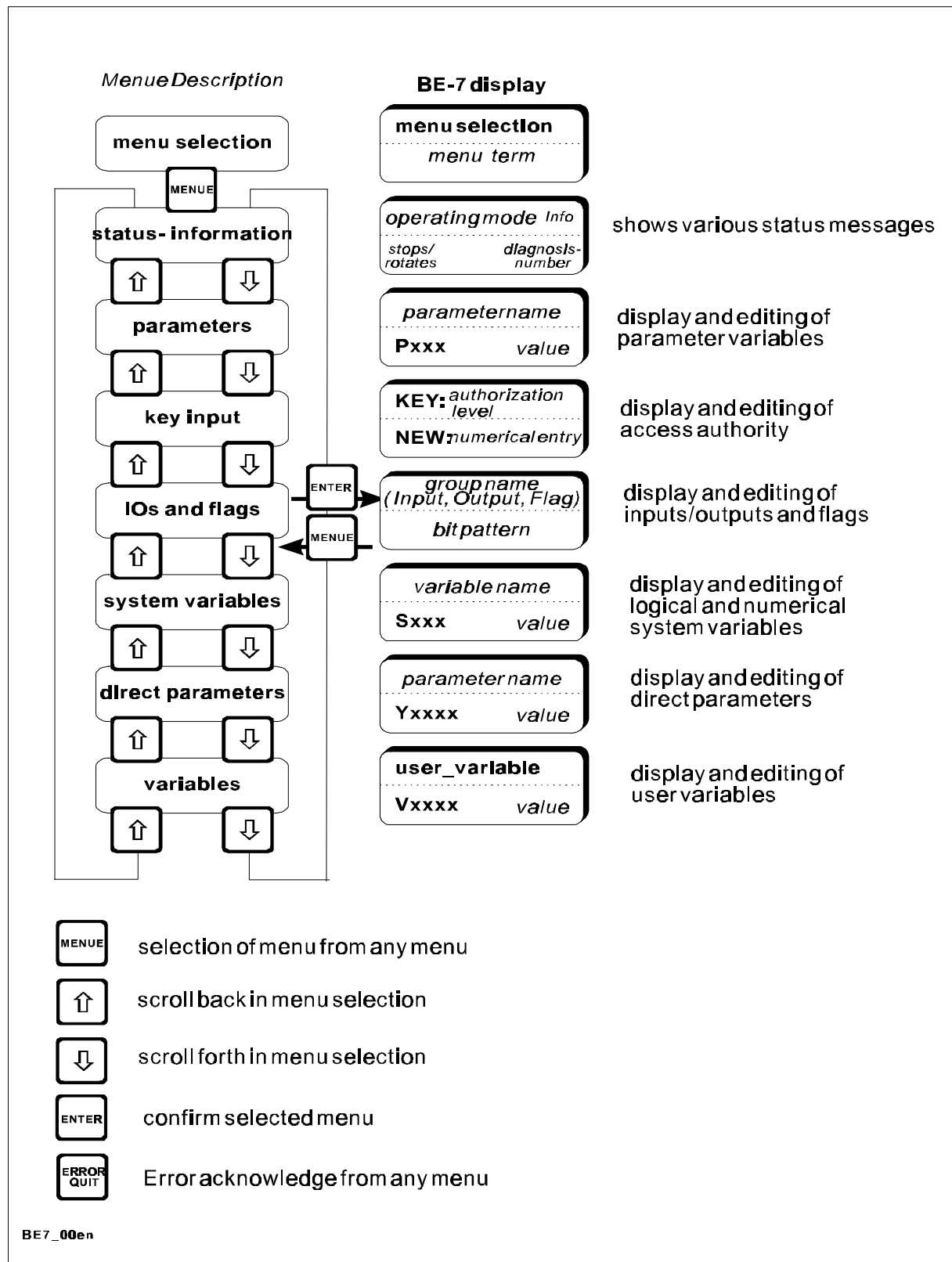

2.5.2 Key input

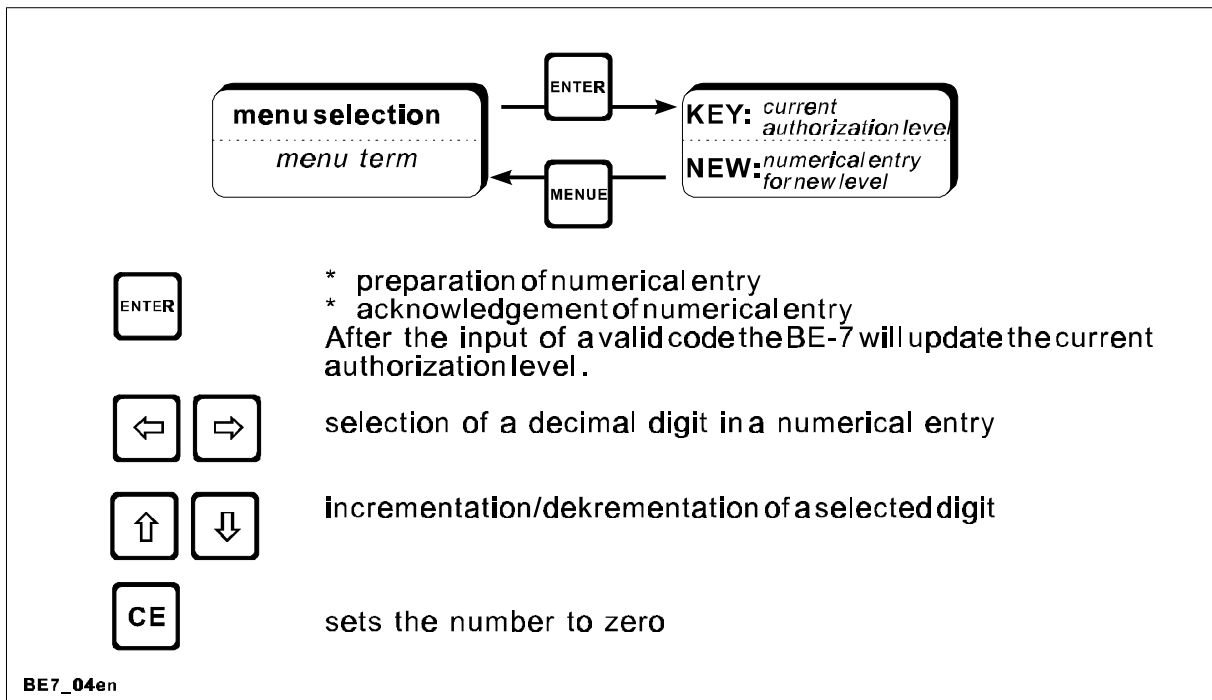

The keys cannot be modified in menu "key input".

„NEW“ means here the entry to another authorisation level, but not the modification of the key.

The keys are set in "General Parameters" P0.18 „Code_Foreman“ and P0.19 „Code_Installer“.

2.5.3 Status information

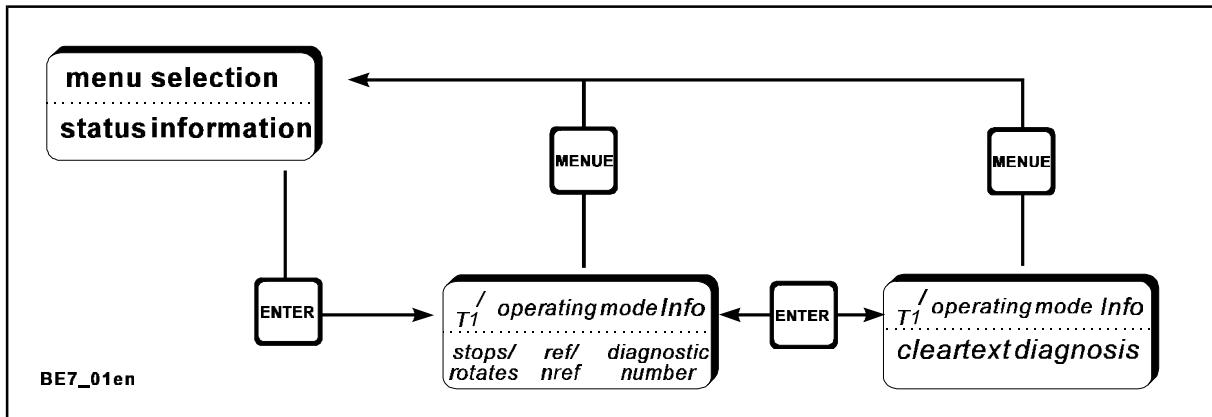

/T1:	T1	standard operation set up, LOW-Power-operation active
Operating mode:	parameter Error1 inactive -> active active -> manual manual -> auto auto	1st initialisation class 1 error no enable or class 2 error dc-circuit tension builds up PMC-2 in automatic control, but without operating mode dc-circuit tension builds up and manual operation preselected manual operation dc-circuit tension builds up and automatic operation preselected automatic operation
Information:	E_Off Qstop stop Sstep	emergency stop active quick stop active start/stop on LOW (in operating mode Auto) single step active
stops/moves:	stops moves	drive does not move drive moves
ref/nref:	ref nref	drive is homed drive is not homed
Diagnosis number:	EXXX	current diagnosis number

2.5.4 Variable and parameter menu

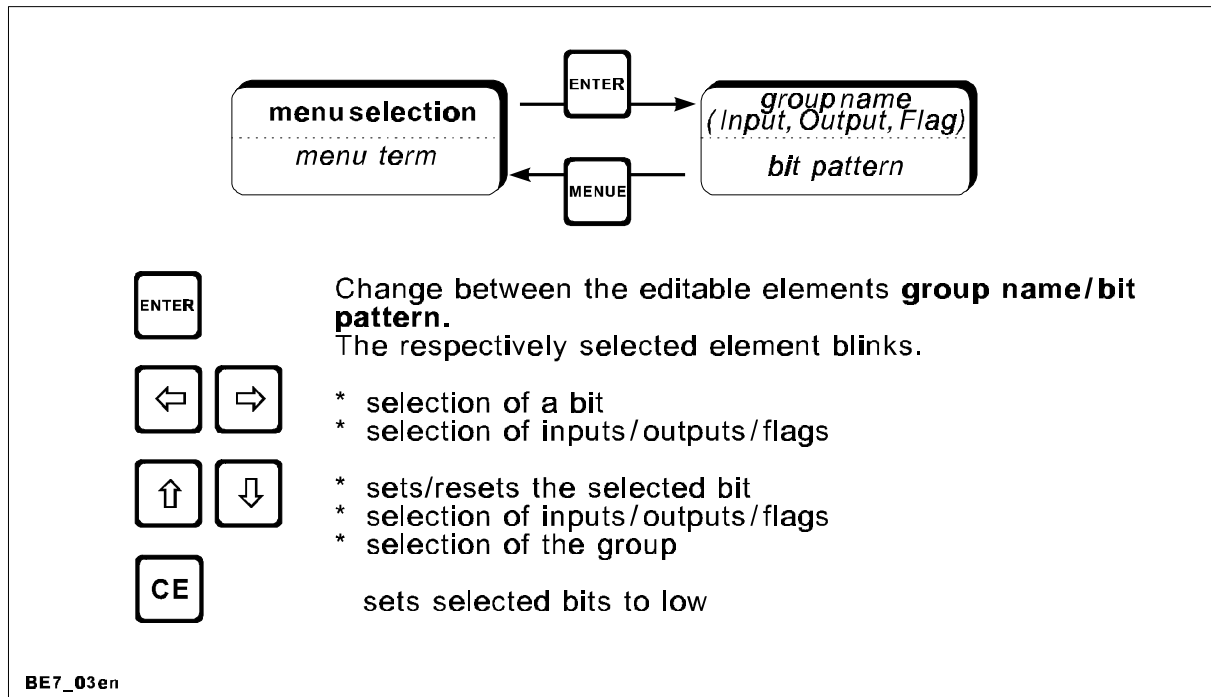

After the input of a parameter (Pxxx), the BE-7 will ask you, if you want the modified parameter record to be transferred to the PMC-2.

A transferred parameter record will only be accepted into the working memory with a positive edge (LOW -> HIGH) on input "Enable".

All other inputs will be accepted right away.

If an arrow key is pressed longer than 1 second, the auto repeat function will be activated.

2.5.5 I/Os and flags

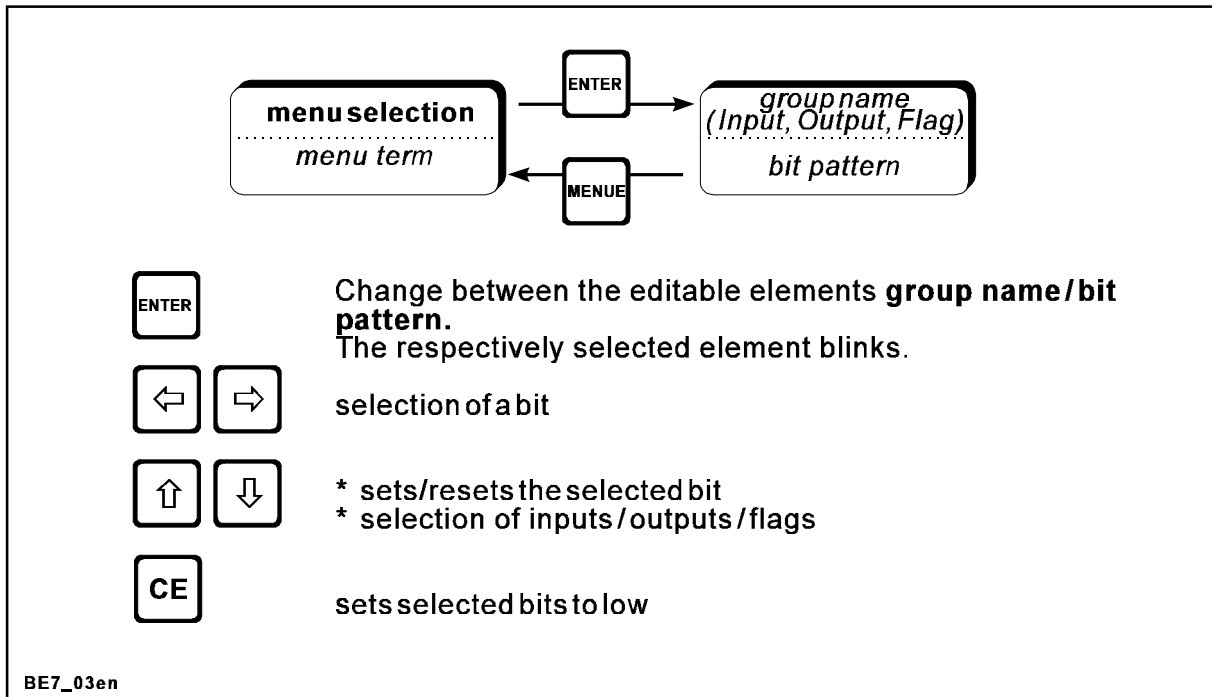

Inputs can only be read.

System outputs can only be read.

Programmable outputs can be read and influenced.

Flags can be read and influenced.

2.5.6 Reset keys

With the BE-7 certain behaviour patterns of the PMC-2 can be selected for reset of the PMC-2. During RESET the BE-7 key must be pressed down.

BE-7 key	Function
ERROR QUIT	load the default parameter set from ROM
CE	after loading the parameter set, P0.26 "COM1_Application" is changed to SINEC_L1_S and P0.27 "COM1_Address" to 1 in RAM.
ENTER	prompt no ECL program

2.6 Operating unit BE-8

2.6.1 Mechanics

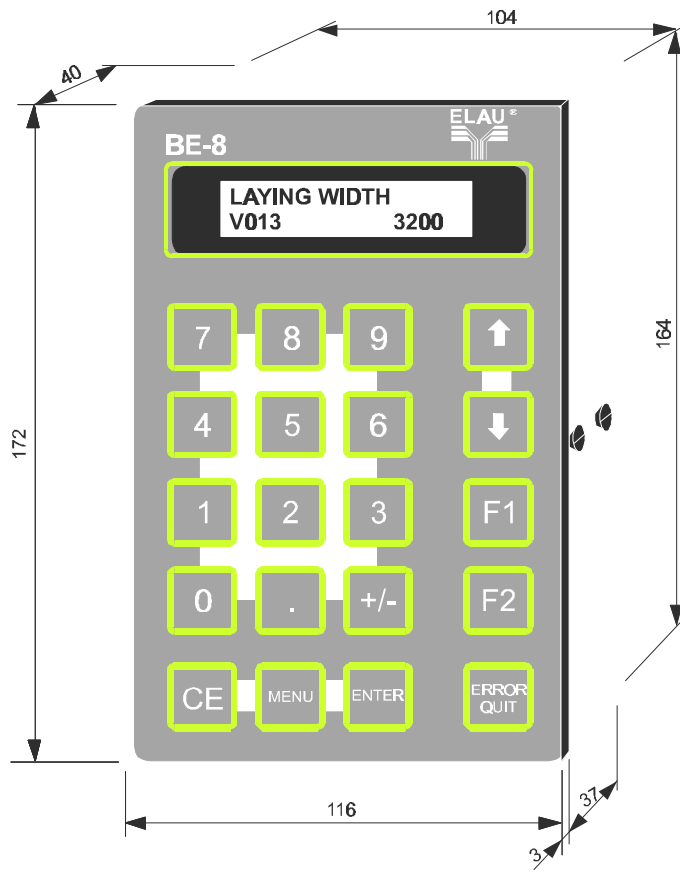

BA_BE8.cdr

BA_BE8.cdr

2.6.2 Initial operation

Power supply of the BE-8 (article number 13130205) is via the COM1 or COM2 interfaces of the PMC-2.

Jumper occupation:

J1	J2	J3	J4
free	used	free	not fitted

The serial interface of the BE-8 is connected to the COM1 or COM2 interface of the PMC-2.
(Setting of the serial interface: 9600, N, 8, 1)

Cables for RS 485

Plug PMC-2

D-sub pin

Pin

- 1
- 2
- 3
- 4
- 5
- 6
- 7
- 8
- 9
- 10
- 11
- 12
- 13
- 14
- 15



bridge
pin 5 - 6

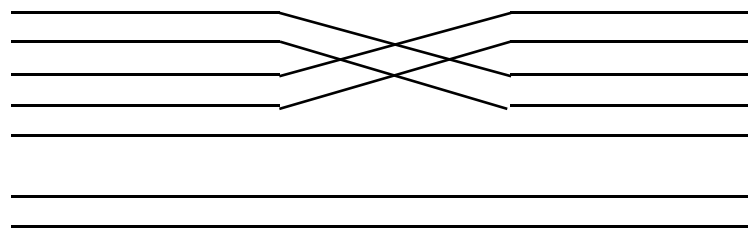

Plug BE-8

D-sub socket

Pin

- 1
- 2
- 3
- 4
- 5
- 6
- 7
- 8
- 9
- 10
- 11
- 12
- 13
- 14
- 15

CAUTION	If the BE-8 is served by the COM2 interface pin 14 and pin 15, the cables should have a minimum diameter of 0.25 mm ² .
----------------	--

Note:

The screen is unilaterally linked to the control by the plug casing.

CAUTION	The BE-8 should be connected to the PMC-2 only in tension-free state.
----------------	---

To activate the BE-8, the parameter **P0.21 COM2_application** or **P0.26 COM1_application** must be set to **BE-8**.

Note:

- Changes in the parameter P0.21 (or P0.26) are not taken over until after RESET at the PMC-2.
- If BE-8 was selected in the parameter P0.21 (or P0.26), also the PMC-2 expects that a BE-8 is connected. Otherwise the warning E587 "BE-Timeout" is triggered.
- If you still get no display in the BE-8, you have probably not yet defined any variables (parameter group 6 -> see 2.6.3 Variable menu).

2.6.3 Variable menu

20 V variables (V0 to V19) can be edited with EPAS-3. Display text, lower limit, upper limit and format are set in parameter group 6.

- The variables must be inputted in a row with no gap, because all following variables after format 0.0 are ignored.
- If the input is to be blocked, the lower limit must be higher than the upper limit.
- Variables are not taken over until format contains a number > 0.0.
- If a variable is inserted or deleted, it is not taken over until after RESET at the PMC-2.
- If the display text, a limit or the format of an existing variable is changed, this is taken over after enable LOW -> HIGH (standard parameter takeover).

Example:

Parameter	Variable	Display text	Lower limit	Upper limit	Format
P 6.00	V0000	Velocity	0	100	3.0
P 6.01	V0001	Laying width	0	10000	5.3
P 6.02	V0002		0	0	0.0
P 6.03	V0003		0	0	0.0
P 6.04	V0004		0	0	0.0
P 6.05	V0005		0	0	0.0
P 6.06	V0006		0	0	0.0
P 6.07	V0007		0	0	0.0
P 6.08	V0008		0	0	0.0
P 6.09	V0009		0	0	0.0
P 6.10	V0010		0	0	0.0
P 6.11	V0011		0	0	0.0
P 6.12	V0012		0	0	0.0
P 6.13	V0013		0	0	0.0
P 6.14	V0014		0	0	0.0
P 6.15	V0015		0	0	0.0
P 6.16	V0016		0	0	0.0
P 6.17	V0017		0	0	0.0
P 6.18	V0018		0	0	0.0
P 6.19	V0019		0	0	0.0

Note:

Format 5.3 means that the number has altogether 5 digits, of which 3 after the decimal point.

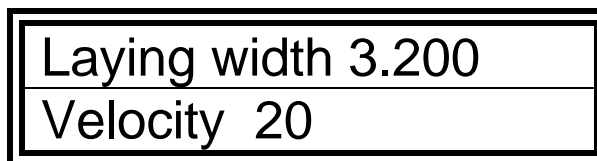

- Working line is the lower line.
- The variable value is flashing.

Note:

In case of large number formats and long texts, it may happen that the number overwrites the variable text from the right end.

CAUTION	If the number to be displayed is larger than the format set, the highest digits are displayed.
----------------	--



- select next-lower variable
- cancel input (old value is retained)

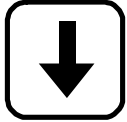

- select next-higher variable
- cancel input (old value is retained)



- deletes the last digit as long as the input is not completed



- takes over the inputted value



- quits an error in the PMC-2



- prepare input (variable value is set to 0)



- no function yet



- no function yet

2.7 Programming

EPAS-3 is responsible for the programming of the PMC-2.

Tailor-made installations are realised with the ECL-ELAU Control Language, which has been successfully used many times in the positioning controls SX-1, SX-2, and SX-3.

ECL-3, for the product family PMC-2, gives the user a powerful tool due to its multitasking capabilities. The compiled ECL-3 program is activated by the ECL runtime system. Up to 8 parallel ECL program parts can be executed at the same time.

For example, one ECL program part takes care of the positioning jobs, whereas a second part concentrates on monitoring functions. Due to the fact that the ECL program is filed in machine code of the micro processor, a high processing speed can be achieved.

The division in single instructions and half textual language elements facilitate the structure of easy-to-survey and easily readable programs.

The ECL-3 offers a comprehensive range of commands:

- program organisation commands
- relative and absolute positioning commands
- synchro positionings (electrical gear, disk cam)
- label positionings
- variable transfer commands
- time commands
- logic and arithmetic commands

The program is created with a menu-guided programming surface on an IBM compatible PC with EPAS-3.

Performance features of EPAS-3:

- pull down menus according to SAA standard
- mouse or keyboard operation
- ECL-3 editor with syntax check
- parameter editor
- variable editor
- filing
- printing
- window system

2.8 Motors

Since ELAU defines itself as a system supplier, it includes high dynamic brushless servo motors SB-056...205 to its range of products.

Performance features of the servo motors:

- torque range from 0,5 to 90 Nm
- Fe Nd B magnets for high temperatures
- resolver feedback; optionally absolute or incremental encoder
- sinusoidal EMK
- high voltage technology = low currents
- low mass moment of inertia
- high durability
- system of protection IP 64
- high overload capability; fivefold peak torque
- with brake, separate fan or gear available
- motor connection and feedback system via connector.

The range of motors provides 5 lines:

SB-056
SB-070
SB-105
SB-145
SB-205

The abbreviation SB stands for Servomotor Brushless, the numbers represent the flange dimensions. There are several torque graduations for each line each providing, in addition to this, different nominal speeds.

The torque graduations in Nm:

SB-056	0.6			
SB-070	0.5	1	1.5	2
SB-105	2	4	6	8
SB-145	8	15	22	28
SB-205	27	50	70	90

The speed graduations in RPM:

SB-056	5000		
SB-070	4000	6000	
SB-105	2000	3000	4000
SB-145	2000	3000	4000
SB-205	1000	2000	3000

3 Safety

3.1 Symbol and note explanations

Safety symbol

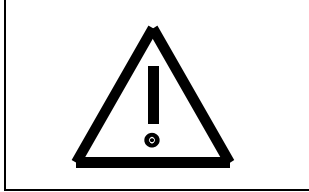

You will find this symbol with all safety instructions in this instruction manual which could be a danger to life and limb of persons. Therefore observe these notes thoroughly and act extremely carefully in those cases. Please pass these safety instructions also to other users.

Caution notes



You will find this "Caution" signal in this instruction manual where you should comply with the directions, instructions, notes and the right course of works as well as where you should avoid a damage or destruction of the equipment.

3.2 Safety information

for electrical equipment of machines for the machine manufacturer.

The machine manufacturer has to undertake a danger, error and risk analysis on the specific conditions of his machine and - with consideration to the effective safety instructions - to watch the corresponding safety installations and measures.

The safety is guaranteed, if uncontrolled movements can be avoided from the standstill and during controlled move of the drive.

The safety arrangements have to be done in a way that no dangerous status could arise in case of an error.

What the safety for persons is concerned this can be achieved, if it is made sure that no person can enter or catch hold of the danger area of the station during its operation (passive protection with access locks, safety fences,...).

The following rules, directions, and instructions are to be observed:

- VDE-0113 part 1
- EN 292 part 1 and part 2
- universally valid regulations for prevention of accidents
- Initial operation must not begin until it has been proven that the machine where the products are built in complies with the EU directive 89/336/EEC (machine directive).
- Operation is allowed only if national rules on electromagnetic tolerance for the respective application are adhered to. In the EU the valid directive is 89/336/EEC.
- DIN EN 50178 on equipment of high-voltage systems with electronic operating means

3.3 General safety instructions:

The following safety notes should be especially observed:

- The safety instructions are to be read and used by each person being occupied with the commissioning, operation, maintenance and repair of the machine.
- In addition to the universally valid national and local regulations for prevention of accidents, pay attention to the notes in this instruction manual.
- Before starting with any work on this equipment, switch the station currentless and secure it against switch on.
- After installation, commissioning or repair of the electrical equipment and of the machine, test the installed protection measures.
- Omit anything which will affect the safety of the machine.
- Unauthorised rebuildings or modifications on the equipment are prohibited due to safety reasons.
- Persons responsible for the safety of the station must guarantee that
 - only qualified personnel will be entrusted with the work on the units and machines
 - the instruction manual will be always available and that they are obliged to obey them.
 - work on the equipment and on the machines is prohibited for unauthorised people.
- When working on the equipment, please observe the corresponding notes on the equipment (e. g. front sides, case, etc.)
- The PMC-2 and the SB-XXX servo motor may only be used for the installations intended in this manual and only in connection with external units and components recommended and authorised by ELAU.
- The flawless and safe function of the product presupposes appropriate transport, storage, arrangement and installation as well as careful service and maintenance.

3.4 Assembly and handling

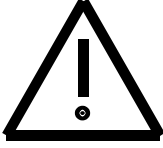
	<p>There is a risk of injuries by squeezing, shearing, cutting or hitting!</p> <p>Observe rules for the prevention of accidents!</p>
---	---

3.5 Safely separated extra-low voltages

Signal voltage and control voltage are <33 Volt and must be executed as extra-low voltages with safe separation. When building in the PMC-2 it must be ensured that the existing safe separation is retained throughout the complete power circuit.

 <p>CAUTION</p>	<p>Wrong connection can result in high electric tensions!</p> <p>Watch the norms! (draft DIN EN 50178/ed. 11.94, section 5.3.1.2)</p>
---	--

3.6 Protection against touching electrical parts

Touching parts with tensions higher than 50 Volt can be dangerous for persons. The operation of electrical appliances necessarily implies that certain parts of these appliances carry a dangerous voltage.

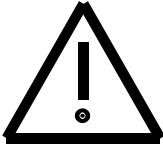
 <p>CAUTION</p>	<p>Touching voltage-carrying parts - even after disconnection from the mains supply - is a life hazard!</p> <p>Wait for more than one minute after switch-off (due to the built-in condensers) before accessing the appliances.</p> <p>After removing the casing or cover or after opening the system cupboard, certain parts of these appliances / systems, which can carry a dangerous voltage, become accessible.</p>
---	---

- After installation, check the firm connection of the earth conductor at all electrical appliances according to the connection plan.
- Operation is permitted **only** with firm connection of the earth conductor at all electrical components. Otherwise high voltages can occur on the casing.
- Before accessing electrical parts with tensions higher than 50 Volt, disconnect the device from the mains supply or the voltage source. Secure against switch-on. Where appropriate, check residual current in the DC-circuit (clamps DC+ and DC-) with voltmeter!
- Do not touch electrical connections of the components when switched on!
- Before switching on the appliance, safely cover up tension-carrying parts to avoid touching.
- Provide for protection against indirect touching (according to draft DIN EN 50178/ed. 11.94, section 5.3.2).

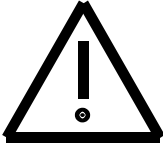
 <p>CAUTION</p>	<p>The PMC-2 leads increased leakage current and may be operated only with connected earth conductor.</p> <p>The leakage current exceeds 3.5 mA. Therefore appliances require a fixed mains connection (according to draft DIN EN 50178/ed. 11.94, section 5.2.11).</p>
---	--

3.7 Protection of dangerous movements

There may be various causes of dangerous movements:

- wiring mistakes
- software errors
- faulty components
- faults in measuring value and signal encoders
- mistakes in operation

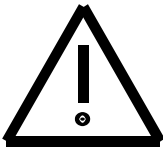
 <p>CAUTION</p>	<p style="text-align: center;">Hazardous movements!</p> <p style="text-align: center;">Risk of life hazard, serious injuries or material damage!</p>
--	---

- Controls at the driving components to a large extent rule out malfunction in the connected drives. For personal protection, one must not rely on these controls alone. Until these built-in controls become effective, one must expect a faulty drive movement the extent of which depends on the kind of malfunction and the operating mode. Therefore personal protection must be ensured by monitoring or superior measures. These are planned by the engineer after a risk and error analysis according to the specific situation of a plant. The respective safety regulations valid for the plant are taken into consideration.
- No person is allowed within the moving range of the machine. This must be ensured e.g. by means of protective fences, grids, covers or photoelectric barriers.
- Sufficient stability of fences and covers to resist maximum possible motive energy.
- The emergency stop switch must be easily accessible and located close to the operators. The functioning of the emergency stop switch must be tested before initial operation.
- Secure against unintentional machine start by enabling the drives' mains connection via emergency stop circuit or use a secure start-up block.
- Before accessing the danger area, bring drives to a standstill.
- Before working at the plant, switch the electrical equipment current-free by main switch and secure against switch-on.
- Avoid operating high-frequency, remote-control and radio devices in the vicinity of the plant electronics and connecting wires. If the use of these devices is inevitable, check system and plant for possible malfunctions in all working situations before initial operation. A special electromagnetic tolerance check for the whole plant may be necessary.

4 Installation notes

This instruction manual gives you the most important basic requirements for the commissioning of the PMC-2 positioning motor controller.

However, before you start with the commissioning, there are some instructions to be observed.

4.1 Protection method

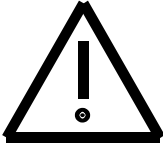
 CAUTION	<p>For the protection of the unit (especially from metallic powder deposit, oil, humidity and strong electromagnetic interference as well as for the observance of the admissible ambient temperature) a system of protection corresponding to the ambient application has to be guaranteed by the mounting.</p> <p>With the installation you have to pay attention to the following rules so as to exclude as far as possible consequences of excessive interference effects.</p>
---	--

4.2 ESD protective measures

CAUTION	<p>Electro static discharge becomes a danger with the increasing miniaturisation for the large-scaled components used, if no protective measures are made during the handling.</p>
----------------	--

Electrostatically endangered components and assembly groups will be furnished with the sticker shown here (or similar).



Therefore:

- do not touch components in a way that you have contact with component pins or strip contactors
- do wear a special wrist ribbon when exchanging components
- do lay components on a conducting earthed padding
- do only transport the PMC-2 in an appropriate packaging (original packaging)

4.3 Mounting

- Mount the units vertically with the power connections on the top side.
- Only connect one motor to each PMC-2.

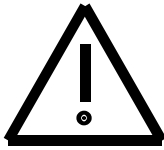

WARNING HIGH VOLTAGE!

Disconnect from mains supply, before working on this equipment. Electric discharge > 1min

Caution!
When exploiting the maximum brake power, the air outlet temperature of the PMC-2 can become >100°C.

- Leave a mounting space of 100 mm on the top, the bottom and the front!
- A free air supply to the fan has to be guaranteed!
- External bleeders should have at least 100 mm distance to all adjacent parts, since they can warm up very greatly; better is an installation outside the electric cabinet.

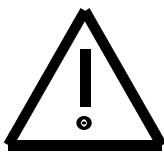

ACHTUNG hohe Temperatur
warning high temperature

Oberfläche des Gerätes im Betriebszustand nicht berühren
do not touch to this surface under operation conditions

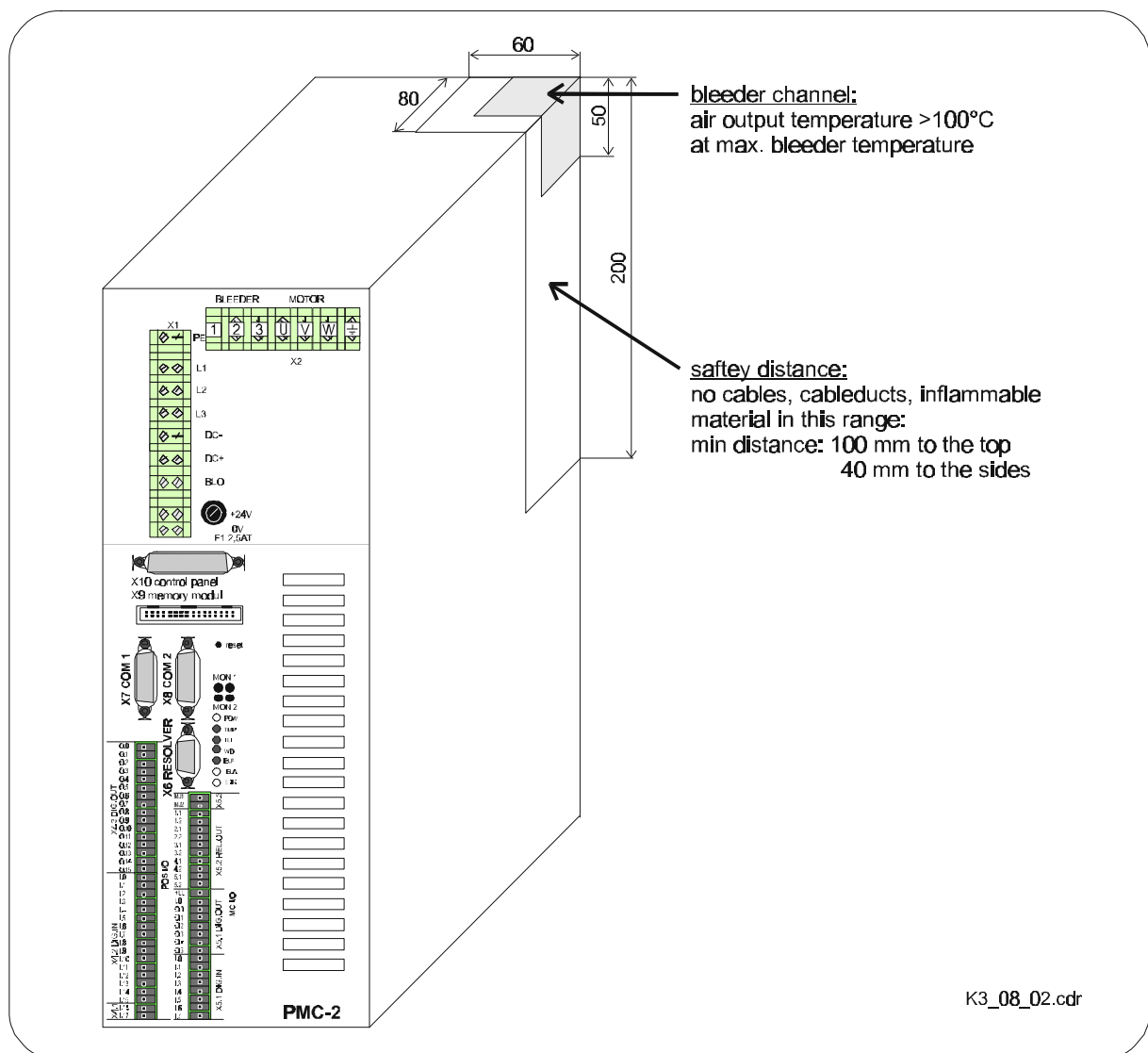

Example of a switching cupboard with ventilation

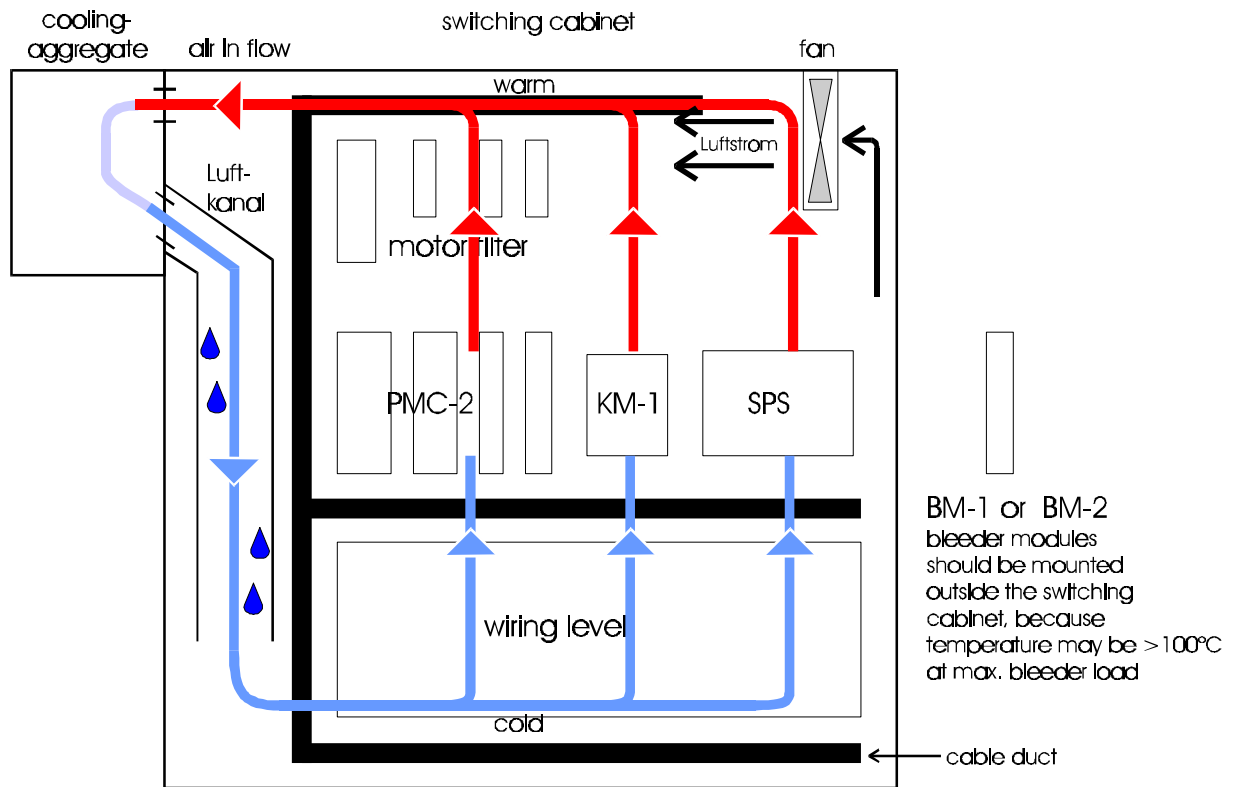

Notes:

- Distance between casings:

short form 2A, 4A, 5A, 8A	>40mm
long form 2A, 5A, 8A	>30mm
short form 16A, 25A	>10mm
- If a DPS-1 option module (PROFIBUS-DP) is used, the minimum distance of the long form may have to be increased due to the PROFIBUS plugs.
- For fixing use cylindrical screws M6 (Inbus screws) and for mounting a hexagonal screwdriver size 5.
- If there are more than three PMC-2s in one switching cupboard, a fan is needed to provide sufficient air flow.

Mounting drawing for the PMC-2 with minimum distances:

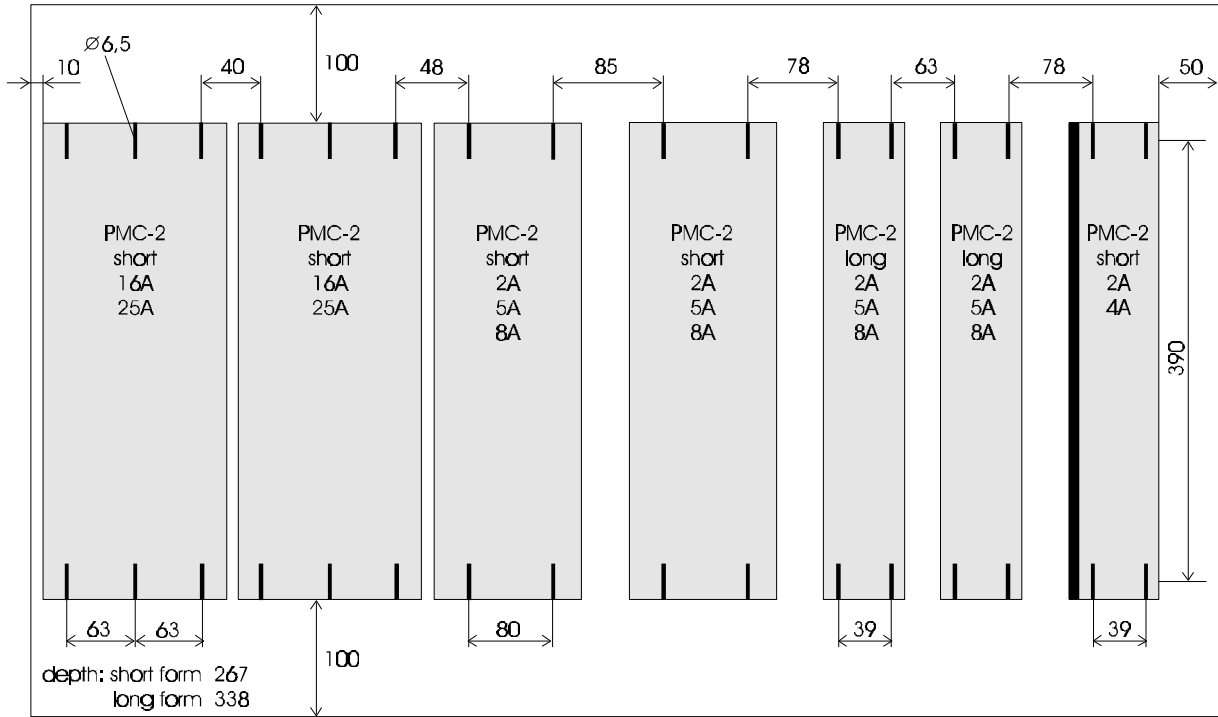

Mounting drawing for the motor filter with minimum distances:

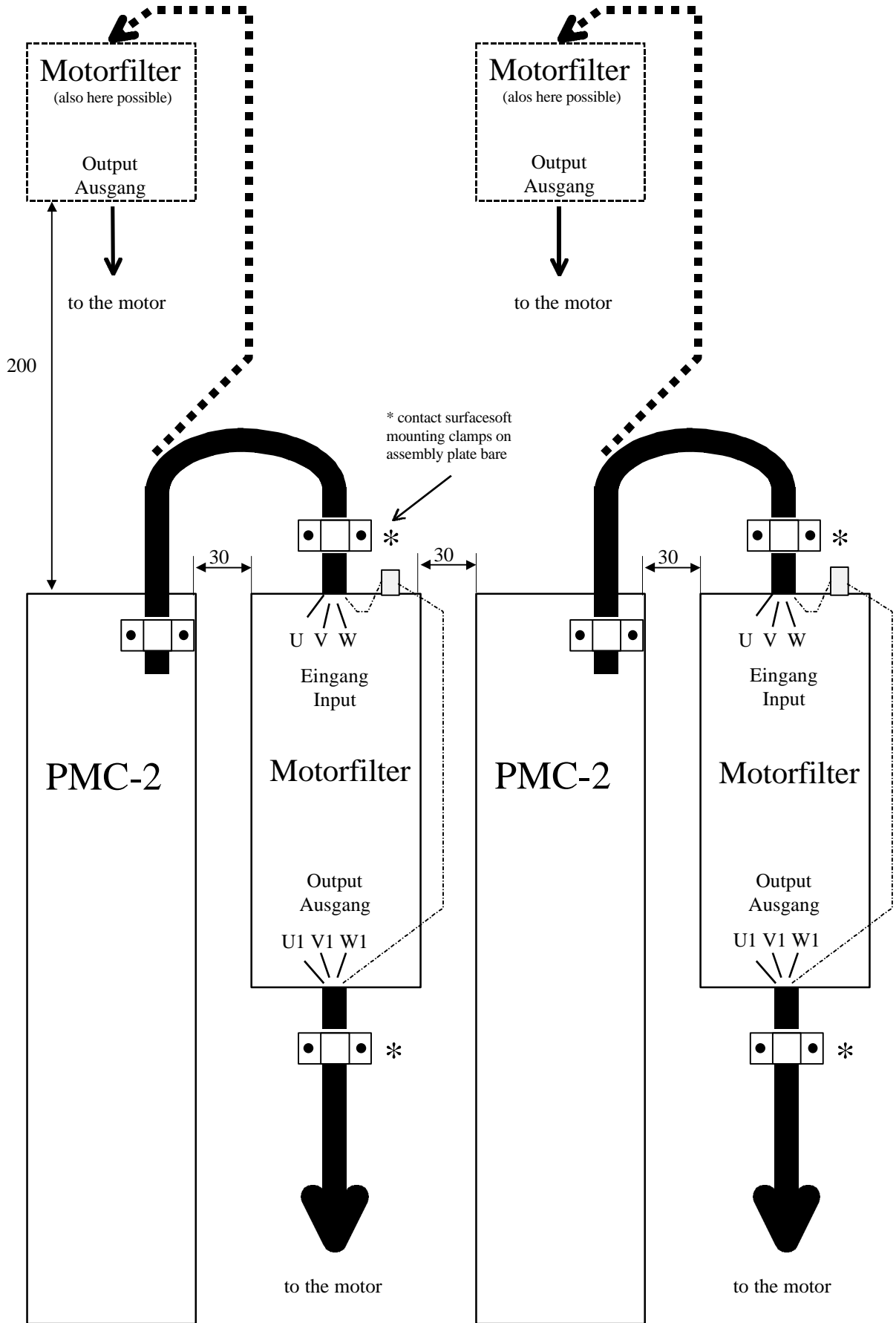

4.4 Wiring notes

4.4.1 General

The wiring has to be done with regard to minimum cross sections, shields and earthings given. Observe the presented branching conditions. If there are, for example, two parallel transmissions starting from one point, it will not be admissible to lay only one transmission and to branch the one on a later point, because induction loops (disturbance sender and aeriels) as well as interfering potential shift could develop.

ELAU as a system supplier provides the ready-made cables.

CAUTION	Minimum bending radius for all ELAU cables is 10 times the cable diameter
----------------	---

If no ELAU cables are used, please watch the following cross sections:

Admissible cable cross sections in dependence of current (VDE 0113), installation type C:

1,5 mm ²	up to 15A
2,5 mm ²	up to 21A
4 mm ²	up to 28A

PMC-2 type	4A	5A	8A	16A	25A
Mains cable in mm ²	1.5	1.5	1.5	2.5	4
Earth conductor to the ZEP in mm ²	10	10	10	10	10
Control signals in mm ²	0.5	0.5	0.5	0.5	0.5
DC-Circuit in mm ²	2.5	2.5	2.5	4	4
external bleeder in mm ²	1.5	1.5	1.5	2.5	2.5

Motor type	SB-070	SB-105	SB-145	SB-205
Motor cable in mm ²	1.5	1.5	1.5 / 2.5 / 4	2.5 / 4

The following cables have to be separately laid and shielded:

- motor cable
- resolver cable
- encoder cable
- serial interface

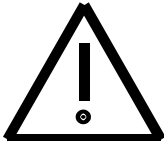
	<p>Check the wiring before the switch on. To avoid errors we recommend you to order the connecting cables together with the PMC-2.</p>
---	--

Frequent errors are:

- wrong shielding of transmissions
- frame or earth circuits
- change by mistake of the motor phases
- change by mistake of the resolver connections

4.4.2 Electromagnetic Tolerance

In general

To control and regulate motors, the mains voltage is stored in the DC-circuit of the PMC-2 by ac-dc conversion. This stored energy is fed to the motor by deliberate switch-on and switch-off of six semiconductor switches. The steep rise and fall of the current poses substantial demands to the insulation ability of the motor winding. Another important aspect to be considered is electromagnetic tolerance with regard to other system components. The high steepness of flanks of the tacted voltage creates harmonic oscillations of great intensity up to the high-frequency range.

Therefore the following rules for electromagnetic tolerance must be observed:

- For installation, choose the lowest-possible earthing option (e.g. unpainted mounting board of the switching cupboard).
- Contact on the largest possible surface (skin effect). If necessary remove existing paint to enable large-surface contact.
- From the central earthing point, lay earthing wires to all connections in a star structure. Earthing loops are not admissible and can cause unnecessary distortions.
- Use shielded cables only
- Only large-surface shield transitions are admissible.
- Contacting of shields by PIN contacts of plugs is not admissible.
- At all means observe switching proposals.
- Cut motor cables to minimum length.
- Do not lay cable loops in the switching cupboard.

Installation

	The following installation rules must be observed to exclude the consequences of excessive distortion effects as far as possible.
---	---

In connection with electronic controls, no inductive loads whatsoever must be switched without appropriate shielding.

Appropriate shielding for dc-operation is achieved by arranging recovery diodes and for ac-operation by arranging commercially available deleting elements compatible with the contactor used.

Only the shielding element mounted immediately at the inductivity serves its purpose. In any other case the switching pulse may even emit increased interference via the cables of the shielding element. It is much easier to avoid sources of interference than to eliminate the effects of existing interference.

In no case must contacts switching unshielded inductive loads be placed in the same room as the PMC-2. The same goes for cables leading unshielded switched inductivity and cables guided parallel to them. The control must be separated from such "disturbance" by a faraday cage (own section in the switching cupboard).

Motor cable	0 - 10m	10 - 20m	20 - 40m	over 40m
SB056 mains filter motor filter	no no	(up to 25m) FI07838 no	(up to 50m) FI07838 FI07837	application specific filters (from 50m)
SB070 mains filter motor filter	no no	(up to 25m) FI07838 no	(up to 50m) FI07838 FI07837	application specific filters(from 50m)
SB105 mains filter motor filter	no no	FI07838 no	FI07838 FI07837	application specific filters
SB145 with PMC-2/8A mains filter motor filter	no no	no	FI07838 FI07837	application specific filters
SB145 from PMC-2/16A mains filter motor filter	no no	no	FI07841 FI07840	application specific filters
SB205 mains filter motor filter	no no	FI07841 no	FI07841 FI07840	application specific filters

Notes::

For groupwise shielding the common mains filter is dimensioned in such a way that $I_{Nominal} \text{ filter} \geq \text{sum } I_{Nominal} \text{ PMC-2}$.

The motor filter is to be mounted above or to the side of the PMC-2.

The motor filter is to be mounted as close as possible to the PMC-2. For cable lengths of less than 0.5 m between filter and PMC-2 no shielding is necessary between filter and PMC-2. Twist the motor cable! The shield is guided directly from the motor cable to the central earthing point!

CAUTION	For cable lengths over 40 (or 50) metres please contact our application department.
----------------	---

Shielding, earthing, potential balancing for the wiring of several PMC-2

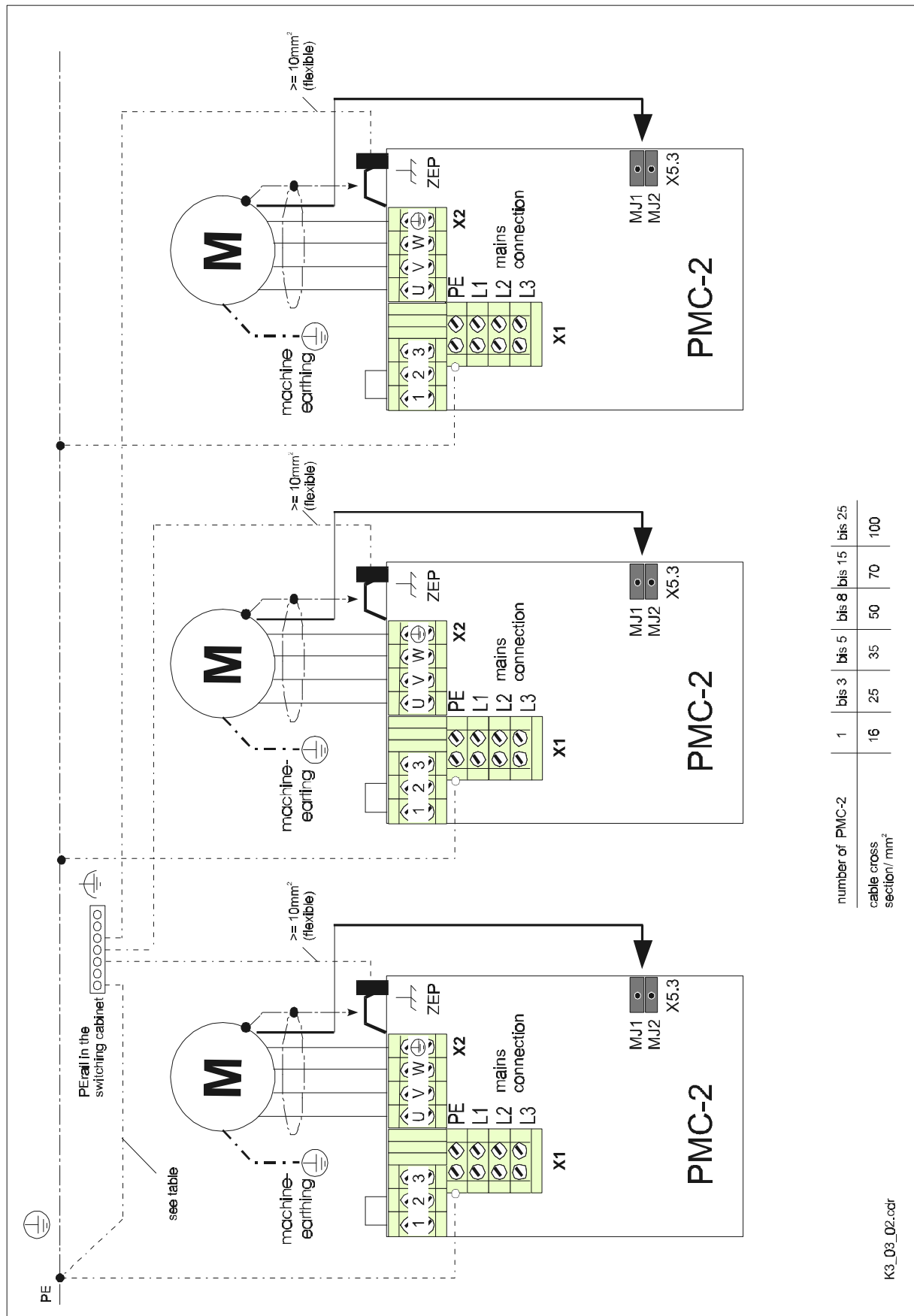

4.4.3 Mains

Fuse protection of mains

CAUTION	The PMC-2 is directly contacted to the 3 AC 400 Volt. A filter is integrated into the PMC-2. The power supply has to be safed by fuses or a power safety switch.
----------------	--

Nominal current PMC-2	Fuse	Power safety switch (e.g. Siemens)	Range	Value
2 A	6 AT	3VU13 00-0ML00	6 ... 10 A	6 A
5 A	10 AT	3VU13 00-0ML00	6 ... 10 A	6 A
8 A	16 AT	3VU13 00-0MM00	10 ... 16 A	10 A
16 A	35 AT	3VU13 00-0MP00	16 ... 25 A	18 A
25 A	50 AT	3VU16 00-0MP00	22 ... 32 A	28 A

For several PMC-2 at one fault current protective gear the following formula applies:

$$I_N = 1,2 * \text{Summe_der_Nennströme}$$

Example:

1 PMC-2/2A + 1 PMC-2/5A + 1 PMC-2 /8A

$1,2 * (2A + 5A + 8A) = 18A$

-> e.g. type 3VU13 00-0MP00, Siemens with 18A set value

Note:

For wiring observe cable cross-sections in relation to power.

Fault current protective gear

Due to the integrated mains filter the PMC-2 has regular leakage current of more than 3.5 mA. This results in incompatibility with general fault current protective gear!

According to DIN VDE 0160, FI compatibility is not required if with connected units a warning sign on the appliances and in the instruction manual points out the increased leakage current and one of the following conditions is met:

- cross section of earth conductor at least $10 \text{ mm}^2 \text{ Cu}$
- monitoring of the earth conductor by an installation which has an automatic switch-off as consequence in case of error.
- placing of a second conductor, electrically parallel to the earth conductor, via separated quandaries. This conductor has to fulfil for itself the requirements according to DIN VDE 0100 part 540.

For further information please see DIN VDE 0160 (EN 590 178)!

Mains contactor

For the dimensioning of the mains contactor the rated powers of the connected PMC-2s must be added and the next higher mains contactor chosen (applied category AC2 and AC3).

Example:

1 PMC-2/2A + 1 PMC-2/5A + 2 PMC-2 /8A

$1 * 1.3\text{kVA} + 1 * 3.4\text{kVA} + 2 * 5.5\text{kVA} = 15.7\text{kVA}$

-> e.g. TYPE 3TF45, Siemens with 18.5 kilowatt

Control voltage

The control voltage can be earthed.

With the 24 V DC for the control voltage also other sinks can be supplied. Please make sure that the tolerances for the 24 V DC control voltage have to be met. This is especially important for applications with inductivities (magnetic valves, brake, etc.).

A checking of the control voltage with a voltmeter is not sufficient. An oscilloscope must be used in order to recognise short-term intrusions in the control voltage (e. g. when switching inductive sinks).

CAUTION	<p>If the tolerances for the control voltage are not observed the following errors could occur:</p> <ul style="list-style-type: none"> • E588 control voltage low • WATCHDOG
----------------	--

Note:

For around 10 ms there is a switch-on power of approx. 10 A per PMC-2.

T1 - operation

The operating mode T1 is for the observing of the safety instructions at stations where works are to be accomplished in danger area (installing and testing the station). The T1-operation of the PMC-2 follows the VDI 2853. Thereby the max. velocity is reduced to 10 % referring to software and hardware. A proceeding of the axis in manual and automatic operation is possible. The restriction on the software side refers to P0.01 V_max. The DC-circuit tension is reduced to 10 % max. of rated voltage by a separate feed. Due to the smaller DC-circuit tension in T1-operation the velocity is effectively limited. Thereby a locking of T1-contactor and mains contactor is necessary due to safety reasons (see 3.4). The monitoring of the DC-circuit tension must be realised externally via over- and undervoltage relay, since the discharging of the DC-circuit without DC-circuit short circuit needs > 1 min. and at the time of commutation the DC-circuit has to be discharged.

	Netzeingang	Zwischenkreisspannung
Normalbetrieb	3*400V AC	560V DC
T1-Betrieb	10 - 40V AC	14 - 56V DC

4.4.4 DC-circuit

The rectification of the power supply and the storage of the electrical energy in the PMC-2 takes place in the so-called direct current circuit. The DC-circuit essentially consists of a rectification and capacitors. With the PMC-2 the DC-circuit voltage is laid on the power plug X1.

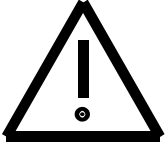
 CAUTION	<p>DC-Voltage can be up to 725V!</p> <p>Isolation of the flexes has to be sufficient!</p> <p>Do not earth the DC-circuit!</p>
---	---

DC-circuit stress limit

In brake operation the servo motor functions as generator and feeds back energy into the DC-circuit via motor dc.-ac. converter. The energy is stored in the DC-circuit capacitors, in this connection the voltage of the dc-circuit increases. If the capacitance of the capacitors is not sufficient to consume the energy incurring, it has to be secured that the DC-circuit voltage does not become too high.

The voltage monitoring registers the DC-circuit voltage and - in case of exceeding a certain limit value - switches the DC-circuit via power transistor to a bleeder, in which the brake energy is transformed into heat. If the DC-circuit voltage drops below the switching threshold (approximately 700 V) the power resistor will be switched-off again.

CAUTION	<p>When utilising the max. braking power the air outlet temperature of the bleeder module can be > 100°C.</p>
----------------	--

Connection of the external bleeder:

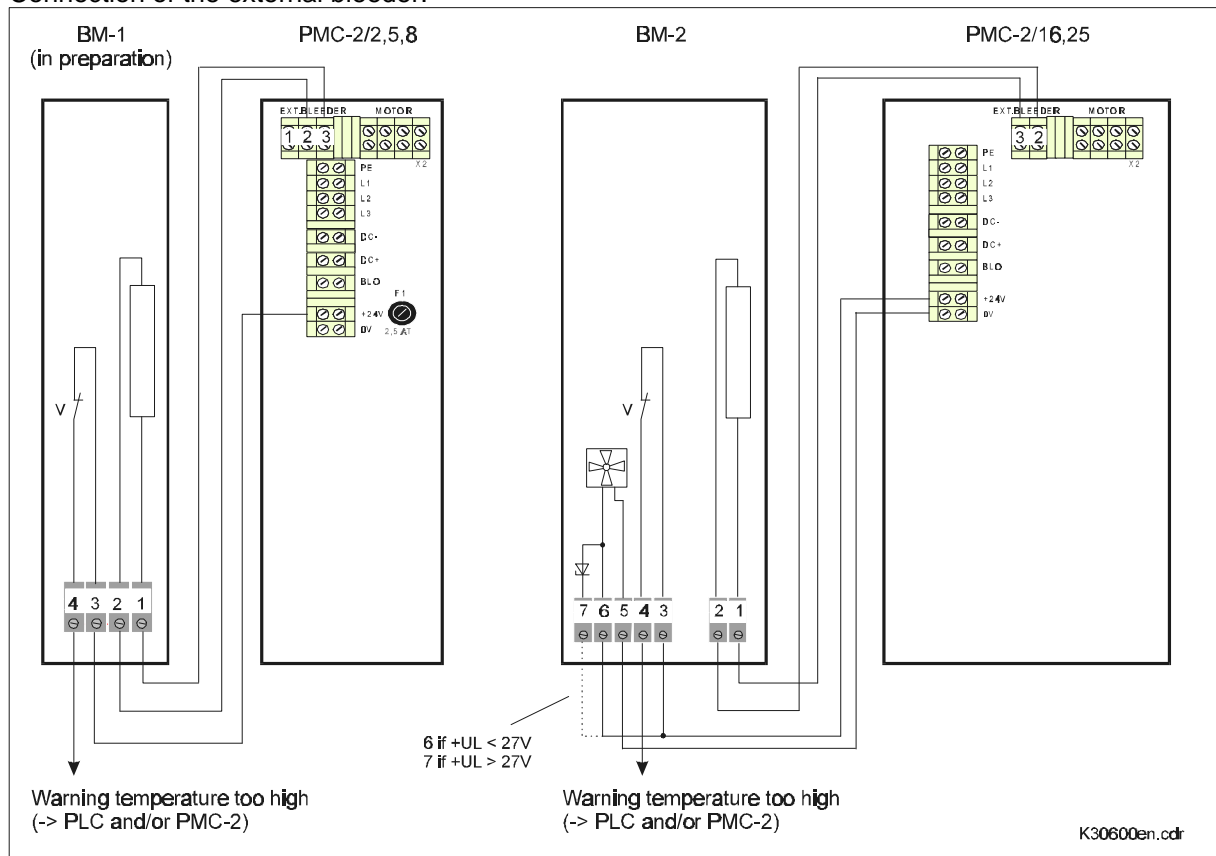

DC-circuit short circuit

With this drive a high safety at standstill of the drive is achieved with little expenditure. The monitorings installed in the drive system are most effectively used.

In cases of EMERGENCY STOP, enable LOW and severe PMC-2 errors the mains contactor will drop and the DC-circuit short circuit contactor will fall-in after a deceleration time (parameter P0.16). The DC-circuit is then discharged by means of a power resistor. Therefore the motors are always stopped in braked manner.

- The DC-circuit short circuit is active for at least 250 ms in order to guarantee a complete discharge of the DC-circuit.
- The power resistor must come to at least 10 Ω. A power resistor BM-1 or BM-2 for single units in the size of the bleeder is recommended (see Technical Data). With a parallel connection of the DC-circuits a BM-2 with 10 Ω (article no. 13270010) is recommended.
- The contactor K3 must be designed for the peak discharge current; its two normally-closed contacts have to be switched in series.

Type Telemecanique LP1-D 25008 / 24 V (article no: 17189003-002) or LC1-D25008 / 230 V (article no. 17189003-001) are recommended.

Additional capacities on the DC-circuit

Due to additional capacities the energy stored will be increased in the DC-circuit.

- At stations in which it is accelerated and braked again shortly one after another, this could be necessary in order to reduce the bleeder's continuous operation and thus the heat loss.
- At stations at which the motor has to finish its movement after cessation of the power supply, the condensator module can supply the required energy.

For units up to 8A nominal power the condensator module KM-1 is available.

CAUTION	When using additional capacities on the DC-circuit please contact our application department.
----------------	---

Bridges of the DC-circuit

With multiple axes applications the DC-circuits of the single PMC-2s can be bridged for energy exchange.

For this purpose the PMC-2s are coupled via the DC-bus. In doing so the terminal BLO has to be bridged between all units as well as the mains feeder L1, L2, and L3. The drive of the joint mains contactor is via series connection of the relay outputs A_mains contactor of the parallely switched units. Each unit can have its own bleeder or all units can have a joint bleeder. It is driven to the LED „BLO“ on all units.

CAUTION	<ul style="list-style-type: none"> • four PMC-2s max. can parallely be switched • the mains feed is on the appliance with the highest performance • the DC-circuit short circuit is on the appliance with the highest performance • with a common bleeder, the bleeder is connected to the appliance with the highest performance • on appliances without an external bleeder the parameter P0.25 bleeder must be set to „no“
----------------	--

CAUTION	BLO, DC+ and DC- must all be bridged in any case (e.g. only mains and BLO is not allowed)
----------------	---

If the option DC-circuit short circuit is used, the contacts O_DC-c_short circuit will have to be switched in series (see drawings on next page; K7).

With T1-operation the digital outputs must be connected to auxiliary relays (K5). (The contacts of the auxiliary relays must be switched in series to the spool of K2 -> see 6.2 The control loop).

-> see also 5. Wiring of the PMC-2 in the system

Depending on the application it can be dispensed with bleeders of individual appliances. Thereby please consider the following:

- the bleeder transistor of the individual appliances is designed for the min. resistance indicated in the data sheet. It must not be remained under this value.
- the bleeder resistance resulting from parallel switches and/or the leave out of individual bleeders must be dimensioned in a way that it can destroy
 - the peak brake performance of the parallelly switched PMCs
 - the continuous brake performance without overheating.

Note:

The times P0.07, P0.16 and P0.17 should be equal in all parallelly switched PMC-2. Otherwise the behaviour is determined e.g. by the shortest time P0.16 for switch-off and the longest time P0.16 for switch-on.

Wiring (appliances with internal bleeder):

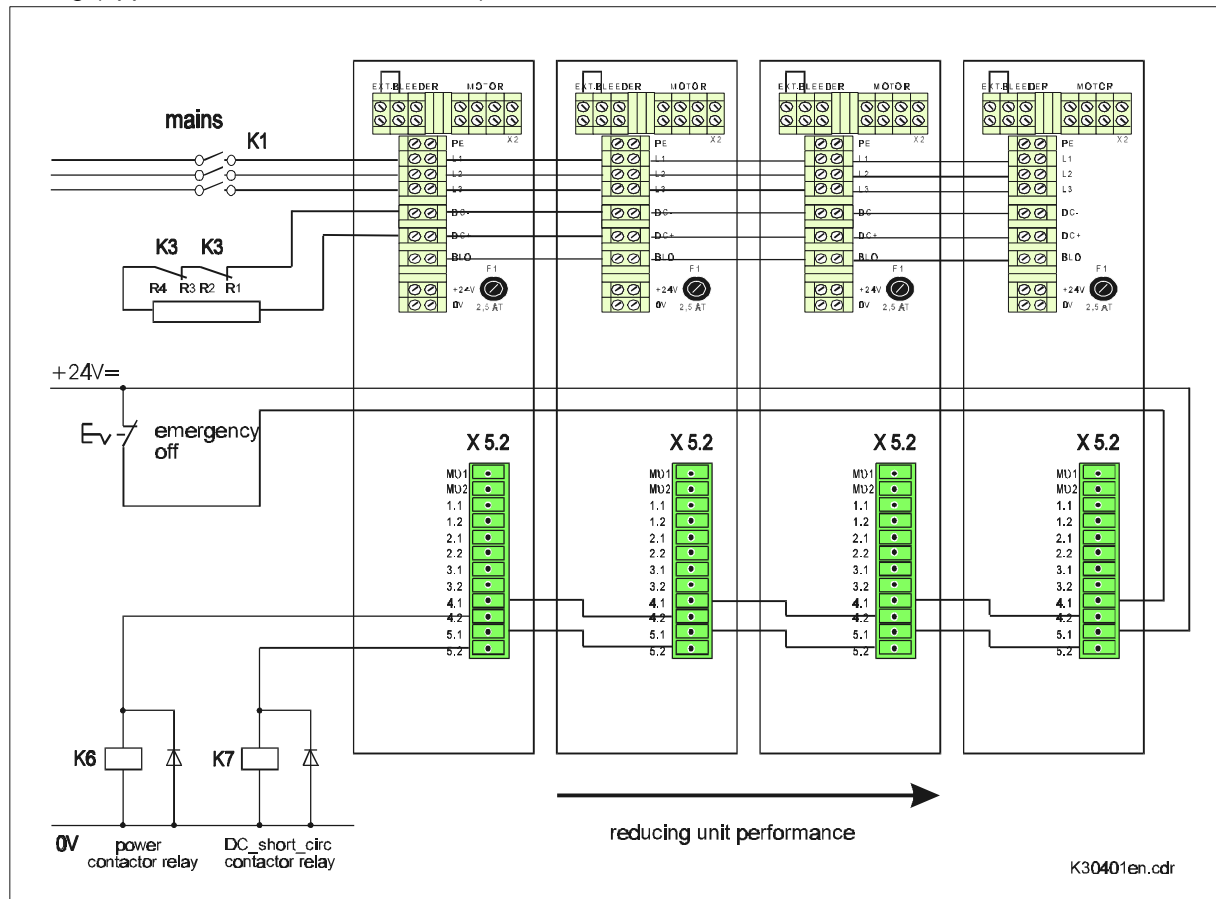

Wiring (external bleeder): Bleeder is simultaneously DC-circuit short circuit resistance

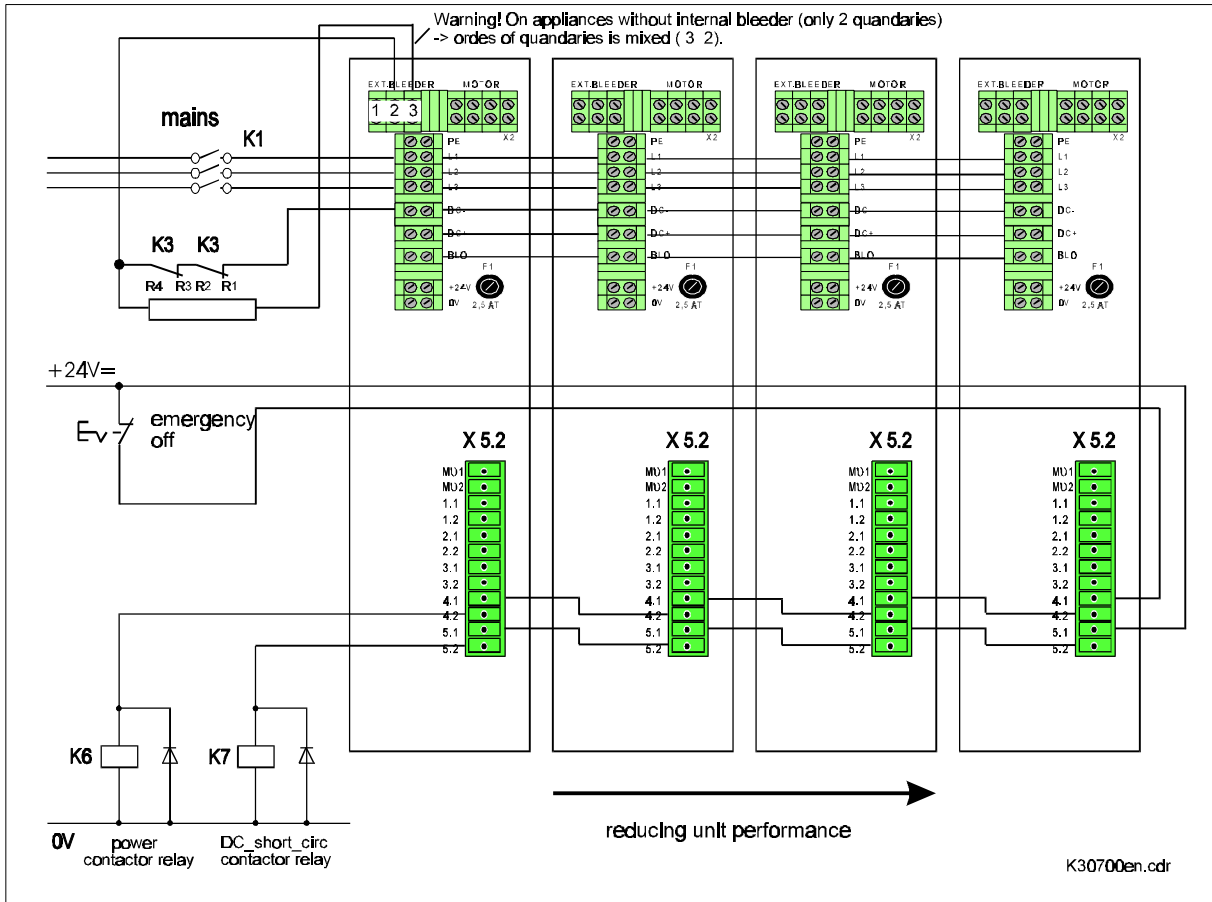

Wiring (external bleeder): As above, but with connection to 16A or 25A compact unit

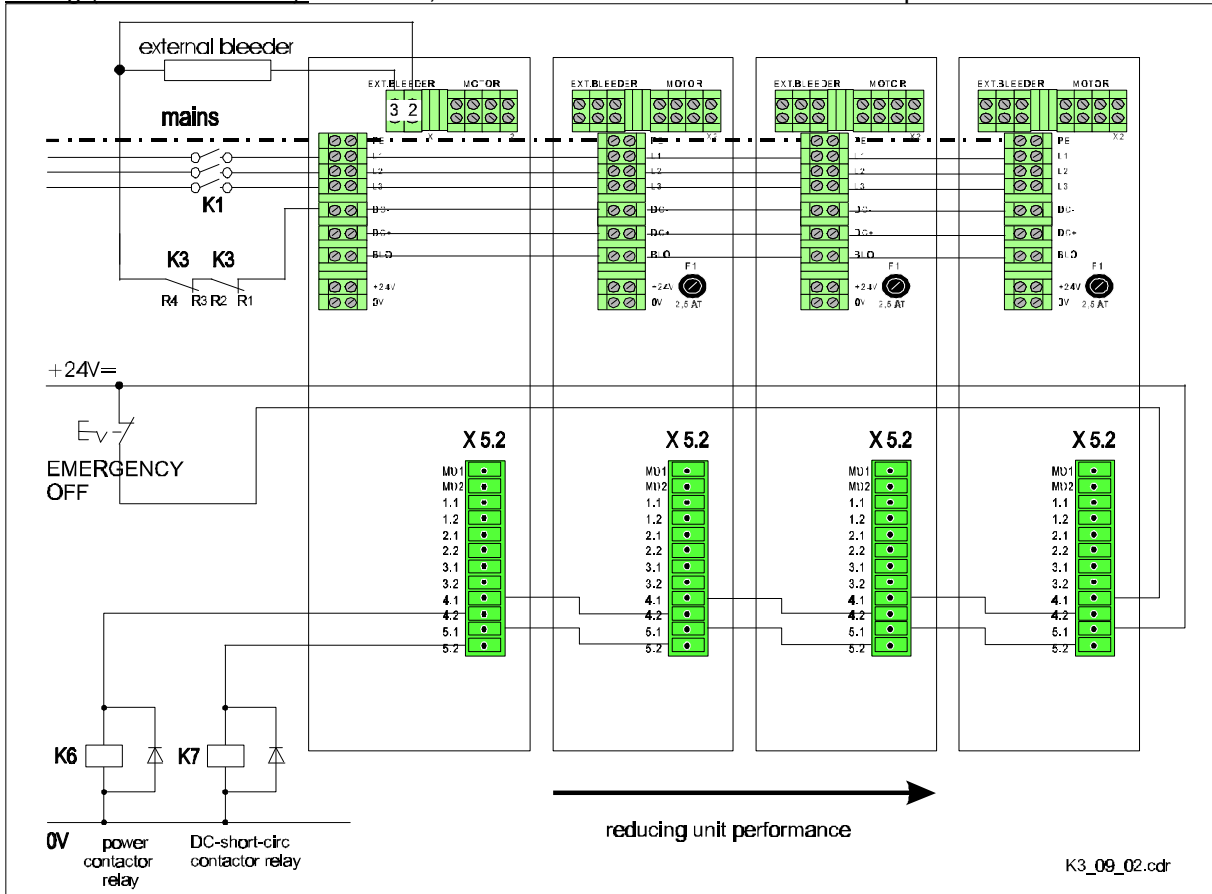

5 Interfaces

5.1 Overview

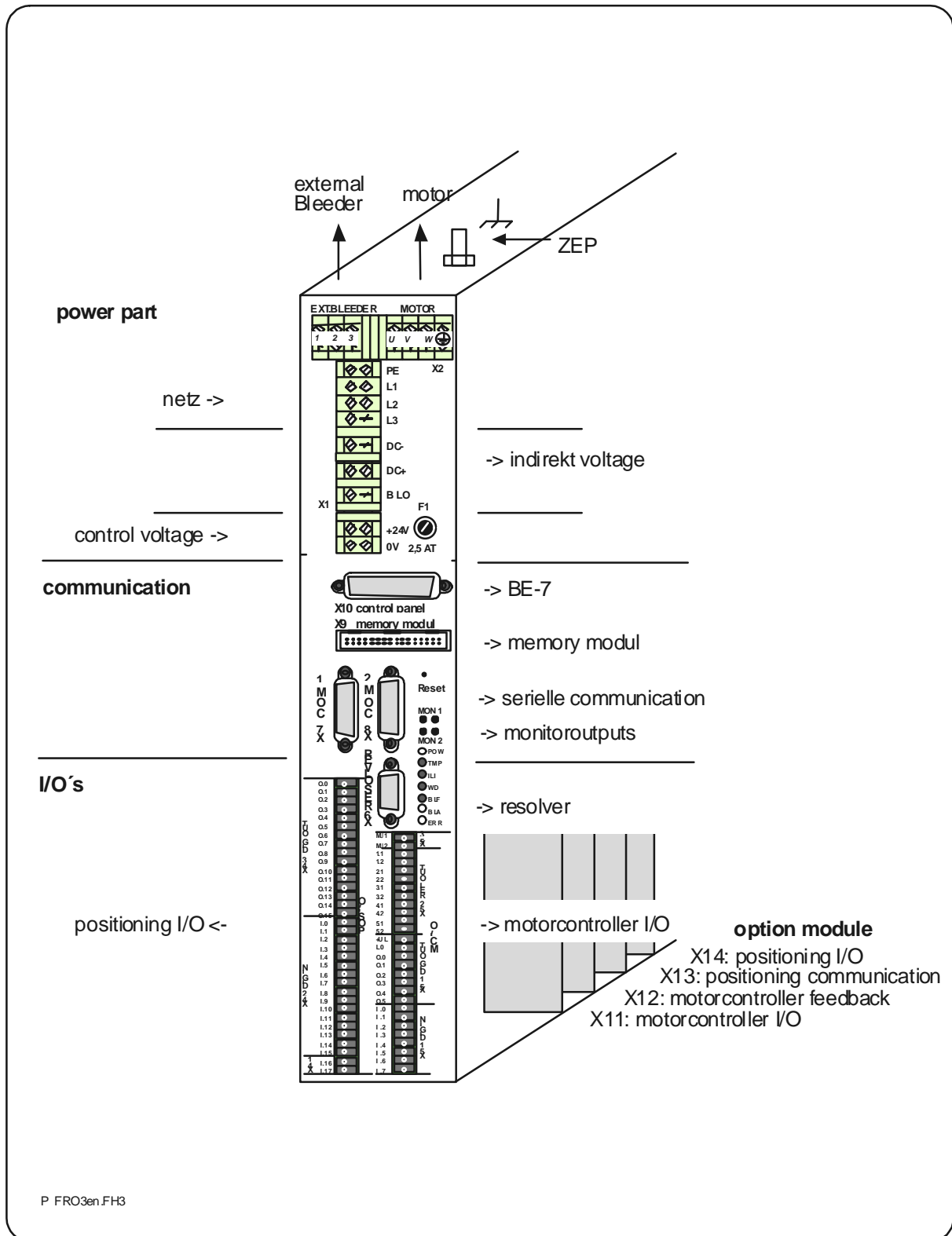

5.2 X1 and X2 power parts

Connector	Pin	Meaning
	PE	Mains connection
	L1	Mains connection
	L2	Mains connection
	L3	Mains connection
	DC -	dc-circuit (basic voltage 510-735 V)
	DC +	dc-circuit (basic voltage 510-735 V)
	BLO	“bleeder on” control signal for bridging of dc-circuits
	+24V	Control voltage (I_max. = 2A) (input)
	0V	Control voltage (input)

CAUTION	The DC must not be earthed.
----------------	-----------------------------

Note:
The 0 Volt of the control voltage (X1 / 0V) can be earthed.

Connector	Pin	Meaning	SB-Motor
X2	1	<- internal bleeder in	
	2	-> Bleeder out	
	3	<- external bleeder in	
	U	Motor	A Motor connection
	V	Motor	B Motor connection
	W	Motor	C Motor connection
		Motor earth conductor connection	D Motor connection

Notes:

internal bleeder bridge X2 pin 1 and pin 2 (mode delivered by manufacturer)
 external bleeder connect X2 bleeder resistor on pin 2 and pin 3

Connector X2:
 Connect the shield of the motor cable at the side of the motor on the connector case and at the side of the PMC1 on the central earthing point. The central earthing point is located on the top of the PMC-2. The motor cable has to be completely shielded.

5.3 X4 Inputs and outputs of the positioning level

Connector	Pin	Meaning	Variable	Factory setup
X4.3	O.0	Outputs	O0.0	Automatic active
	O.1		O0.1	Manual active
	O.2		O0.2	Ready for operation
	O.3		O0.3	Disturbance
	O.4		O0.4	Warning
	O.5		O0.5	TP1 active
	O.6		O0.6	homed
	O.7		O0.7	Homing active
	O.8		O0.8	
	O.9		O0.9	
	O.10		O0.10	
	O.11		O0.11	
	O.12		O0.12	
	O.13		O0.13	
	O.14		O0.14	
O.15		O0.15		
X4.2	I.0	Inputs	I0.0	Automatic
	I.1		I0.1	Manual
	I.2		I0.2	T1
	I.3		I0.3	Quick stop
	I.4		I0.4	Error acknowledgement
	I.5		I0.5	Start/manual drive positive
	I.6		I0.6	Single step/manual drive negative
	I.7		I0.7	Homing
	I.8		I0.8	Quick motion/creep speed for manual operation
	I.9		I0.9	
	I.10		I0.10	
	I.11		I0.11	
	I.12		I0.12	
	I.13		I0.13	
	I.14		I0.14	
I.15		I0.15		
X4.1	I.16	Interrupt In IRQ 1	S0.18	Fixed assignment
	I.17	Interrupt In IRQ 2	S0.19	Fixed assignment

Note:

The factory-set assignments can be modified in the parameters.
(parameter P5.00)

5.4 X5 Inputs and outputs of the motor controller

Connector	Pin	Meaning	Variable
X5.3	MØ1	Connection motor temperature switch or PTC	S0.16
	MØ2		
X5.2	1.1	O_disturbance (normally-closed contact)	S1.03
	1.2		
	2.1	O_warning (normally-closed contact)	S1.04
	2.2		
	3.1	O_brake (normally-open contact)	S0.06
	3.2		
	4.1	O_mains contactor (normally-open contact)	S0.07
	4.2		
	5.1	O_ZK_short circuit (normally-open contact)	S0.08
5.2			
X5.1	+UL	+ 24V	Power supply of the I/O level and motor temperature monitoring logic
	L0	L0	
	O.0	Output Drive moves	S0.00
	O.1	Output In target window	S0.01
	O.2	Output Free	
	O.3	Output Free	
	O.4	Output Motor temperature too high	S0.16
	O.5	Output T1_operation active	S0.09
	I.0	Input Enable	S0.10
	I.1	Input Emergency stop (LOW active)	S0.17
	I.2	Input Free	
	I.3	Input Homing switch	S0.13
	I.4	Input Positive limit switch	S0.14
	I.5	Input Negative limit switch	S0.15
I.6	Input Touchprobe_1	S0.11	
I.7	Input Touchprobe_2	S0.12	

Note:

The relay outputs X5.2 can be stressed with max. 200mA and 60 V.

The relay outputs X5.2 have a contact protection against overstress (PTC in series with the respective contact).

The 0 Volt (L0) of the I/O level (connector X5.1/L0) can be earthed.

galvanic separation:

All I/Os of the positioning level and the motor controller are internally guided by opto-controller. To use this galvanic separation in the optimal way, a separate mains contactor must be used for the 24V control voltage (plug X1). The 0V must not be earthed.

5.5 X6 Resolver

Connector	Pin	Meaning	SB-Motor
X6	1	free	
D-Sub	2	free	
outlet	3	SIN -	E Resolver connection
	4	COS -	C Resolver connection
	5	EXCT -	B Resolver connection
	6	free	
	7	SIN +	F Resolver connection
	8	COS +	D Resolver connection
	9	EXCV +	A Resolver connection

Note:

The shield is laid on both sides of the plug casing.

5.6 X7 COM1 and X8 COM2

Connector	Pin	Meaning
X7 / X8	1	free
D-Sub	2	TxD RS 232
outlet	3	RxD RS 232
	4	> RS 232 out
	5	< COM in
	6	> RS 485 out
	7	GND RS 232
	8	TxD - RS 485
	9	TxD + RS 485
	10	RxD - RS 485
	11	RxD + RS 485
	12	GND RS 485
	13	free
	14	GND
	15	+ 5V

RS 232 interface (bridge from pin 5 to pin 4 in the respective cable)

- Only one drive can be operated with EPAS-3 via RS 232 interface
- Maximum transmission length is 10m.

RS interface 485 (bridge from pin 5 to pin 6 in the respective cable)

- Realisation of a serial bus with up to 32 participants
- Maximum transmission length is 100m.
- Initial operation of several PMC-2 with EPAS-3 without changing the interface cable to new plug



Note:

The shield is connected unilaterally with the PMC-2 via connector case.

5.7 Interfaces of the additional cards

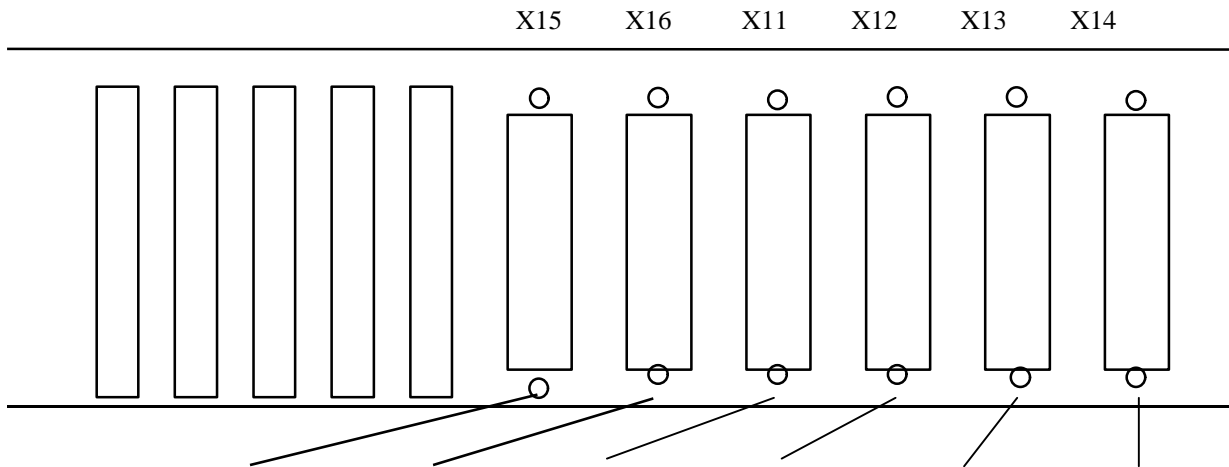
Occupation of places for the option modules (-> see also S9.12 - S9.15)



Plug	X15	X16 Encoder 2	X11	X12 Encoder	X13 Communication	X14 Analog I/O
ANA-1						DSUB 15pole pin
BHS-1					LWL  	
IBS-2	DSUB 9pole socket (outgoing interface)				DSUB 9pole pin (ingoing interface)	
DPS-1					DSUB 9pole socket	
FLB-1	DSUB 9pole socket (outgoing interface)		DSUB 9pole socket (ingoing interface)			
IKA-1		DSUB 15pole socket INK-input	DSUB 9pole pin analog input	DSUB 9pole socket encoder simulation		
INK-1		DSUB 15pole socket encoder 2		DSUB 15pole socket encoder 1		
SSI-1		DSUB 15pole socket encoder 2		DSUB 15pole socket encoder 1		
SCI-1		DSUB 15pole pin SINCOS 2 or DSUB 15pole socket INK-encoder 2		DSUB 15pole pin encoder 1		

5.7.1 X12 encoder

SINCOS module SCI-1

The PMC-2 can read high-resolution rotation encoders (SINCOS encoders) via the option module SCI-1. In addition, the SCI-1 has an incremental encoder input. Two SINCOS encoders or one SINCOS and one incremental encoder can be connected.

SINCOS encoder inputs

Connector (X12/X16)	15 pole D-Sub pin
Encoder supply voltage power	+11V DC max. 100mA per encoder
Analog traces	difference inputs (SIN, REFSIN / COS, REFCOS) max. input level 1,1 Vss max. input frequency 200kHz
Parameter channel	asynchronous bidirectional RS485 interface

Incremental encoder input

Connector (X16)	15 pole D-Sub socket
Overload protection	no short circuit protection
Signal traces	Level acc. to RS 422, for incremental encoder with rectangular signals
Input frequency	max. 250kHz
Pulse multiplication	4

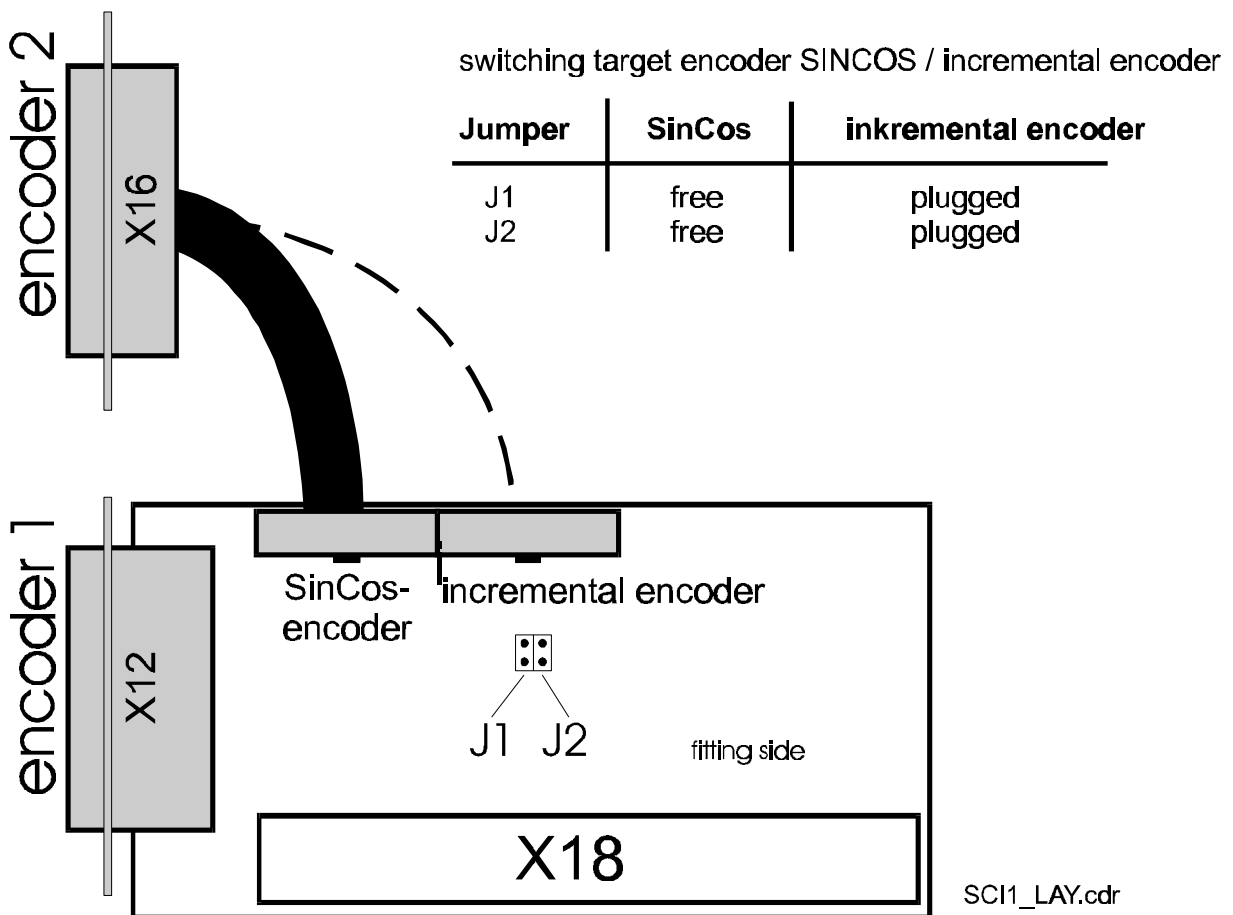

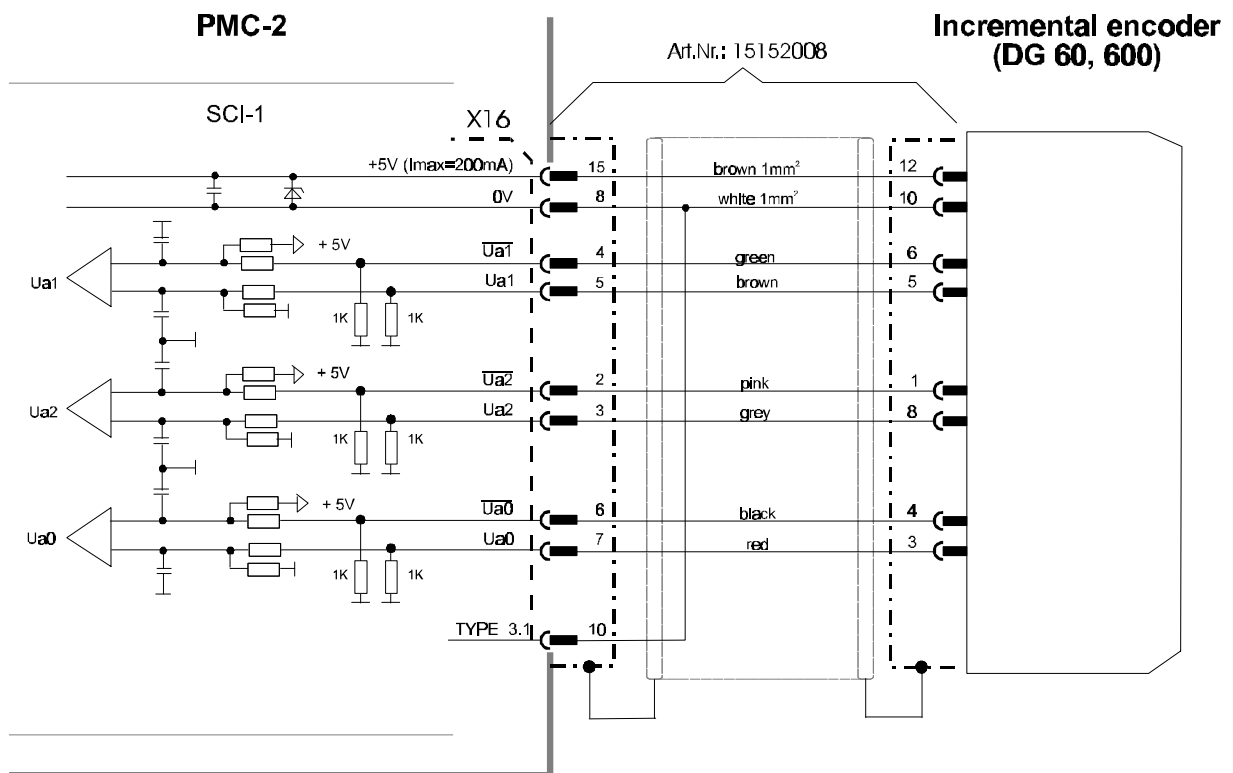
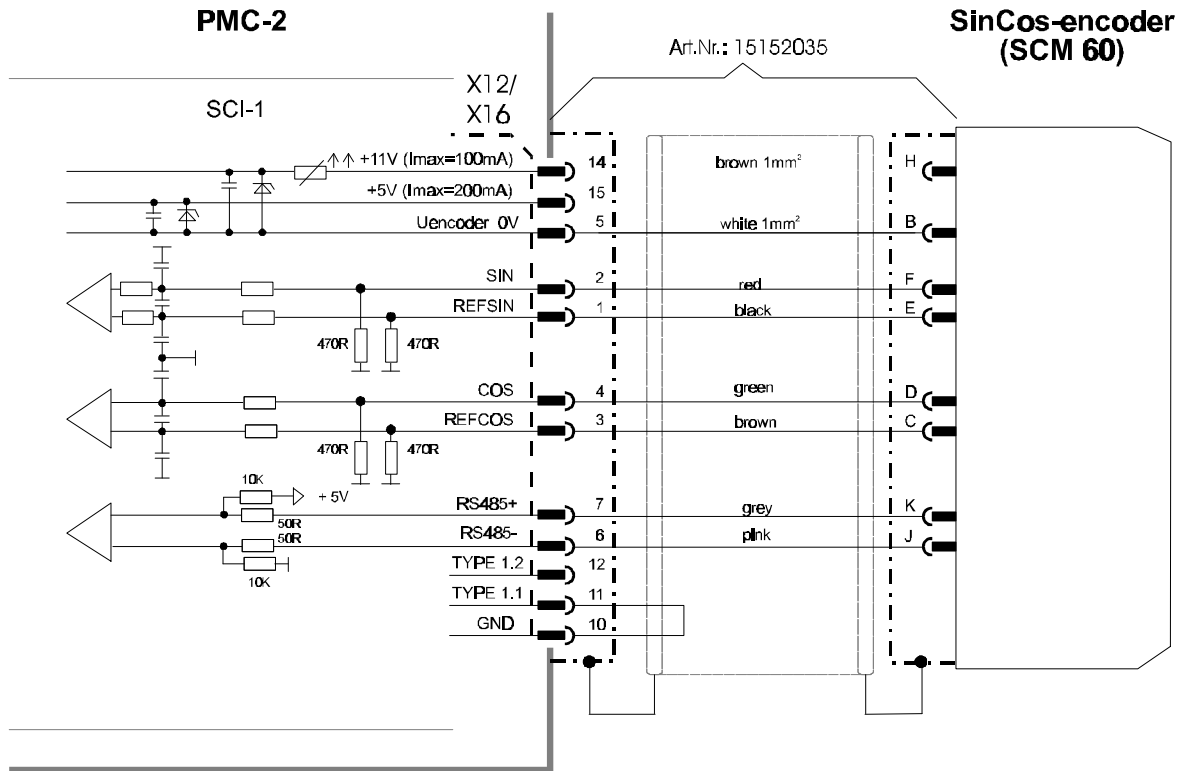

SCI1_X12.cdr

Incremental encoder simulation module IKA-1

The option module converts the position values from the resolver into incremental encoder signals and passes them on to other positioning controls (e.g. SX-2, PMC-2). In addition, the module has an analog set value input which can additionally read in voltage (-10 ... +10V) or power (0 ... 20mA). In addition an incremental encoder input was realised.

Encoder emulation output

Connector (X12)	9 pole D-Sub socket
Signal traces	level according to RS422, for incremental encoders with rectangular signals
Input frequency	max. input frequency 250kHz
Increments per rotation	2048 incr/rotation (encoder 1)

Analog input

Connector (X11)	9 pole D-Sub pin
Analog input for input voltage for input power	-10V ... +10V 0 ... 20mA
Reference voltage	+15V / -15V

Incremental encoder input (optional)

Connector (X16)	15 pole D-Sub socket
Overload protection	no short circuit protection
Signal traces	Level according to RS 422, for incremental encoders with rectangular signals
Input frequency	max. 250kHz
Pulse multiplication	4

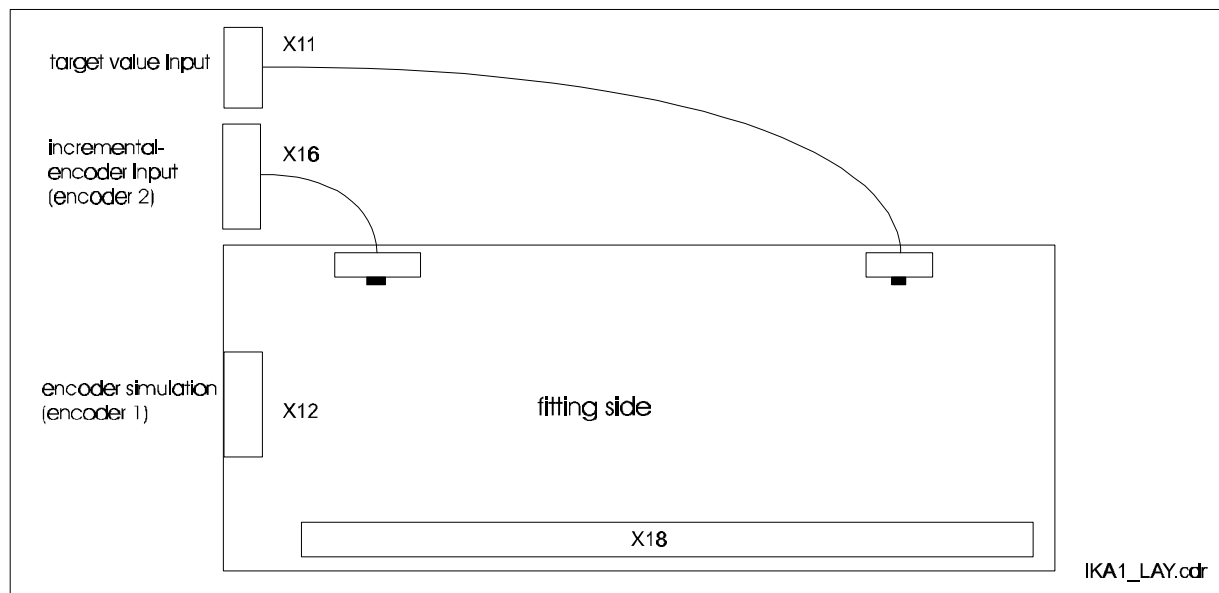

CAUTION	To ensure correct functioning of the encoder simulation, "resolution_enc_1" (P3.03) must be equal to "resolution_enc_0" (P3.00).
----------------	--

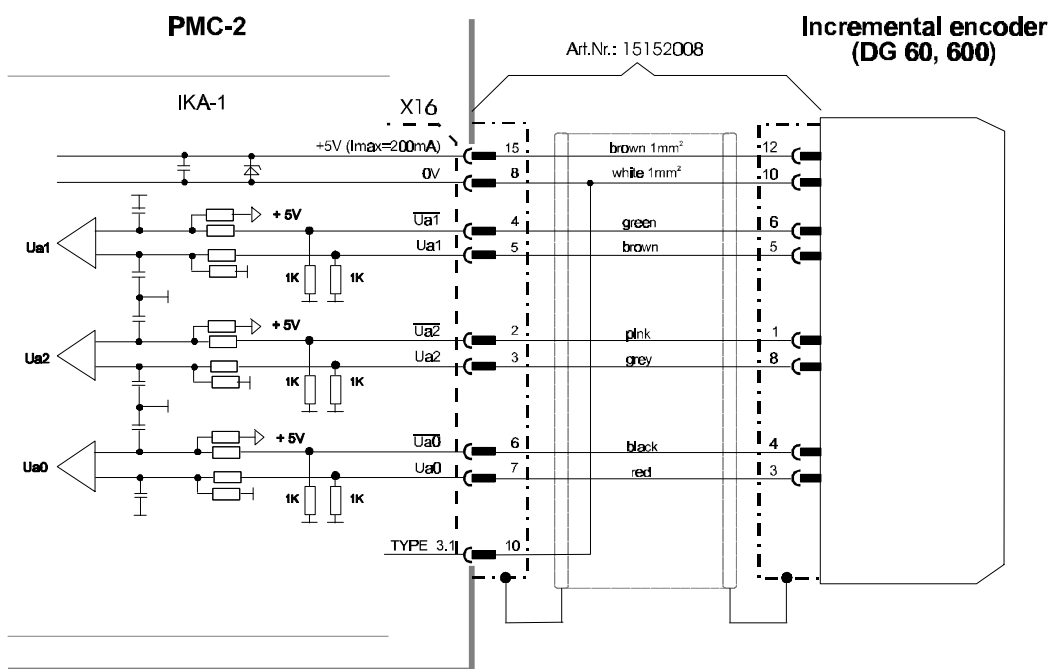
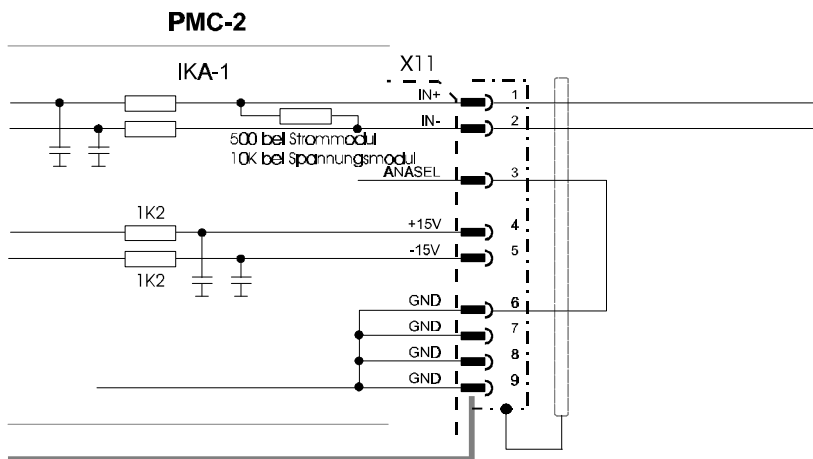
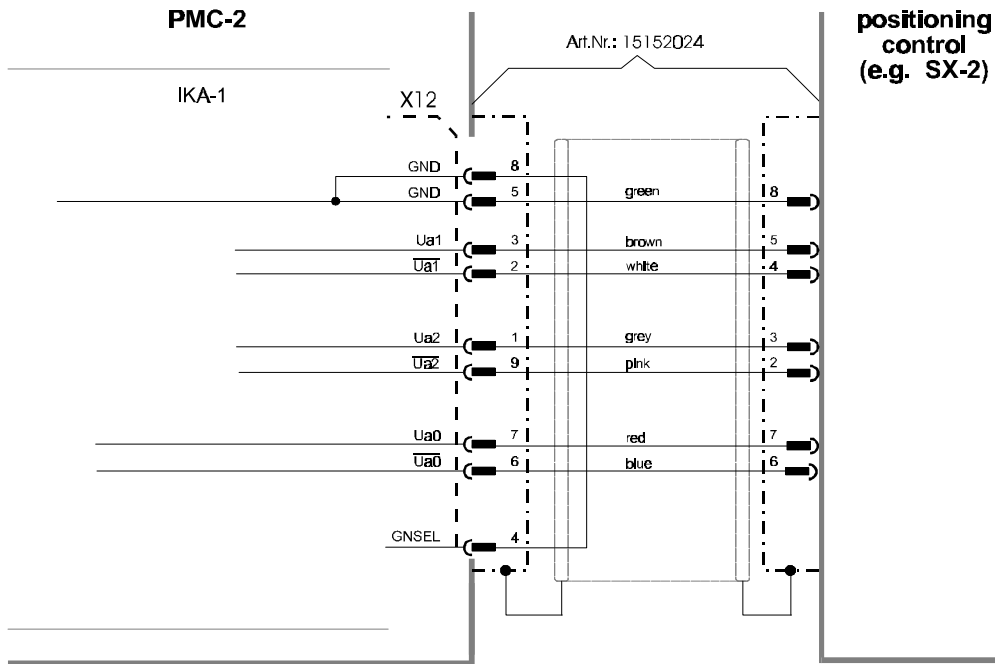

IKA1_X12.cdr

Incremental encoder module INK-1

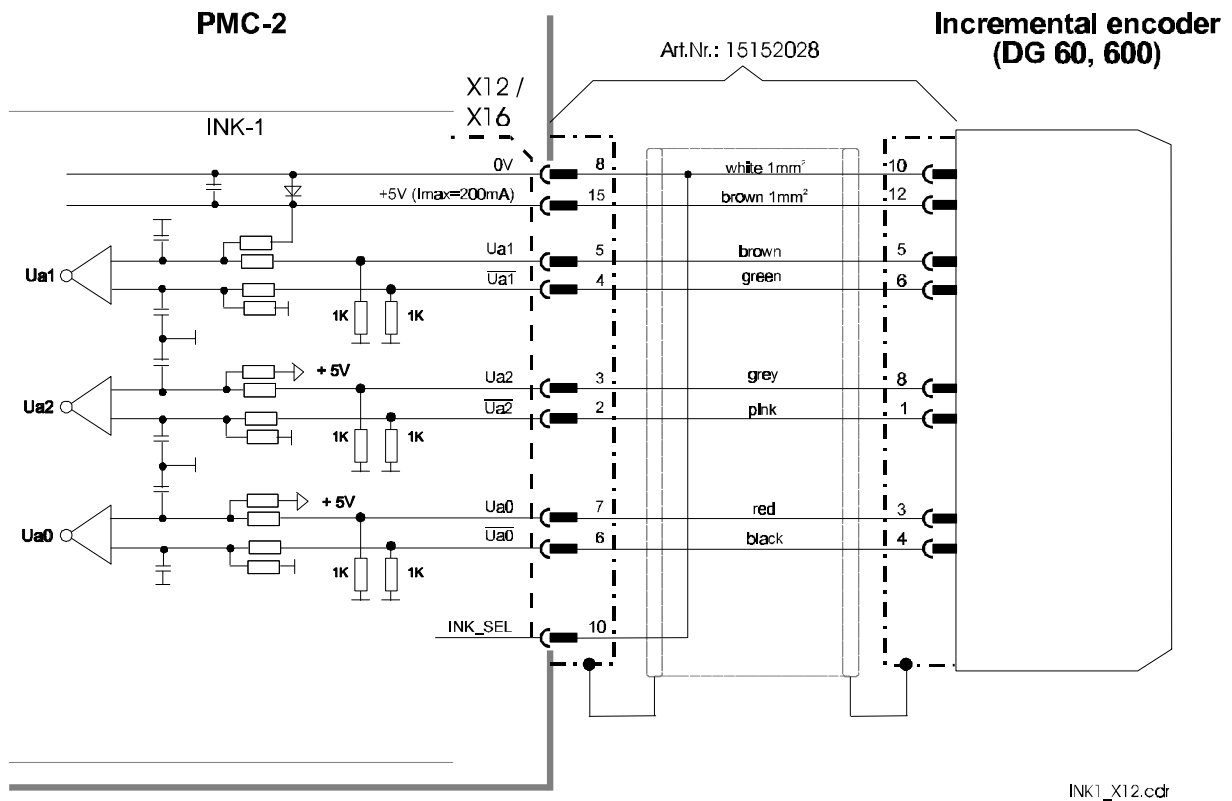

Absolute value encoder module SSI-1

Connector	Pin	Meaning
X12/X12.1 D-Sub socket	1	0V
	2	free
	3	free
	4	free
	5	free
	6	free
	7	free
	8	free
	9	Uabs (U = 15V DC; I _{max} = 0.4A)
	10	free
	11	loop in +
	12	loop in -
	13	loop out +
	14	loop out -
	15	free

Notes:

Only one incremental encoder module INK-1 or one absolute encoder module SSI-1 can be used. For the incremental value encoder pulse multiplication is preset at 4t (standard).

5.7.2 X14 Analog I/O module

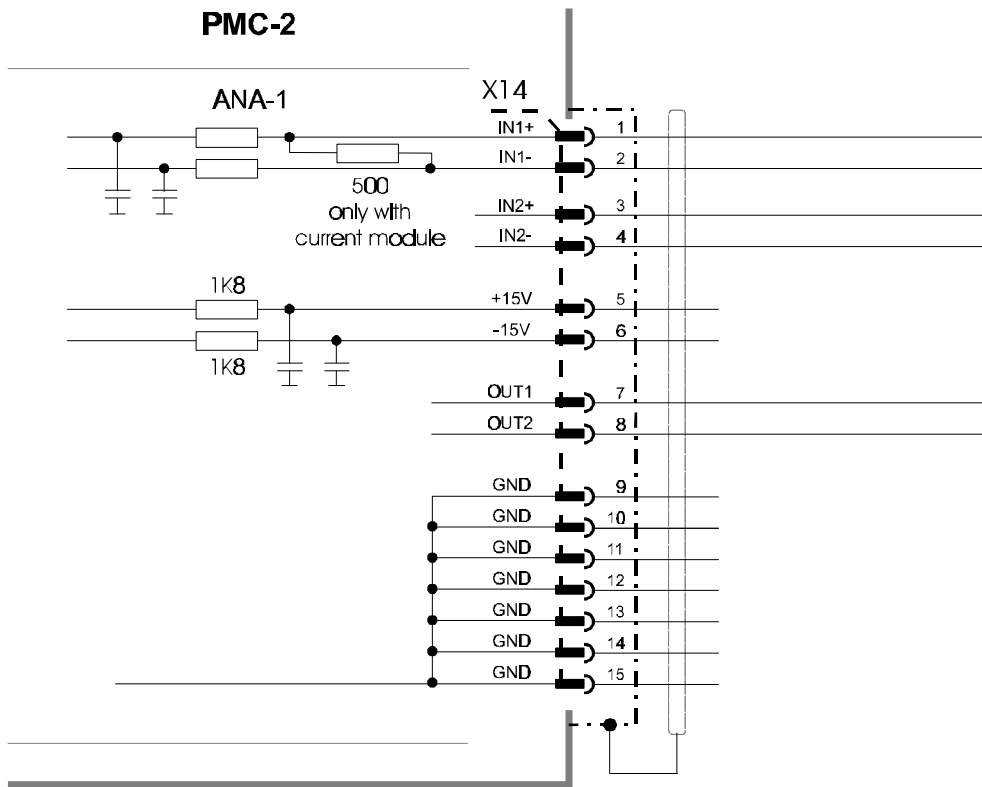

5.7.3 Other option modules

For the settings for other option not mentioned here, please see chapter 8 “Technical data” of the user documentation.

5.8 Motor connector SB-056...205

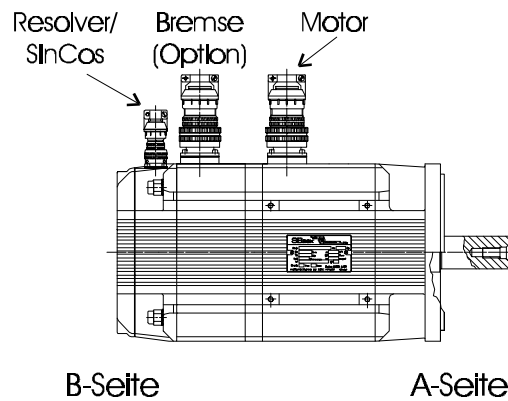

5.8.1 Motor

Connector	Pin	Meaning	PMC-2
MIL Pin	A	U	X2 U
	B	V	X2 V
	C	W	X2 W
	D	Earth conductor	X2 Earth conductor
	E	Mø1 temperature contact	X5.3 Mø1
	F	Mø2 temperature contact	X5.3 Mø2
	G	free	
connector case		Cable shielding	CEP

5.8.2 Resolver or SINCOS

Connector	Pin	Meaning (resolver)	PMC-2
MIL Pin	A	EXCT +	X6 9
	B	EXCT -	X6 5
	C	COS -	X6 4
	D	COS +	X6 8
	E	SIN -	X6 3
	F	SIN +	X6 7
	G	Cable shielding	X6 Connector case
	H	free	
	J	free	
	K	free	

Connector	Pin	Meaning (SINCOS)	PMC-2
MIL Pin	A	free	
	B	0V encoder	X12 5
	C	REVCOS	X12 3
	D	COS	X12 4
	E	REFSIN	X12 1
	F	SIN	X12 2
	G	free	
	H	11V encoder	X12 14
	J	- RS485	X12 6
	K	+ RS485	X12 7
connector case		cable shielding	X12 Connector case

5.8.3 Brake

Connector	Pin	Meaning	Switching cabinet
MIL Pin	A	+ 24V DC	Brake contactor
	B	0V	L0
	C	free	
connector case		Cable shielding	PE

6 Wiring of the PMC-2 in the system

6.1 Mains and motor connection

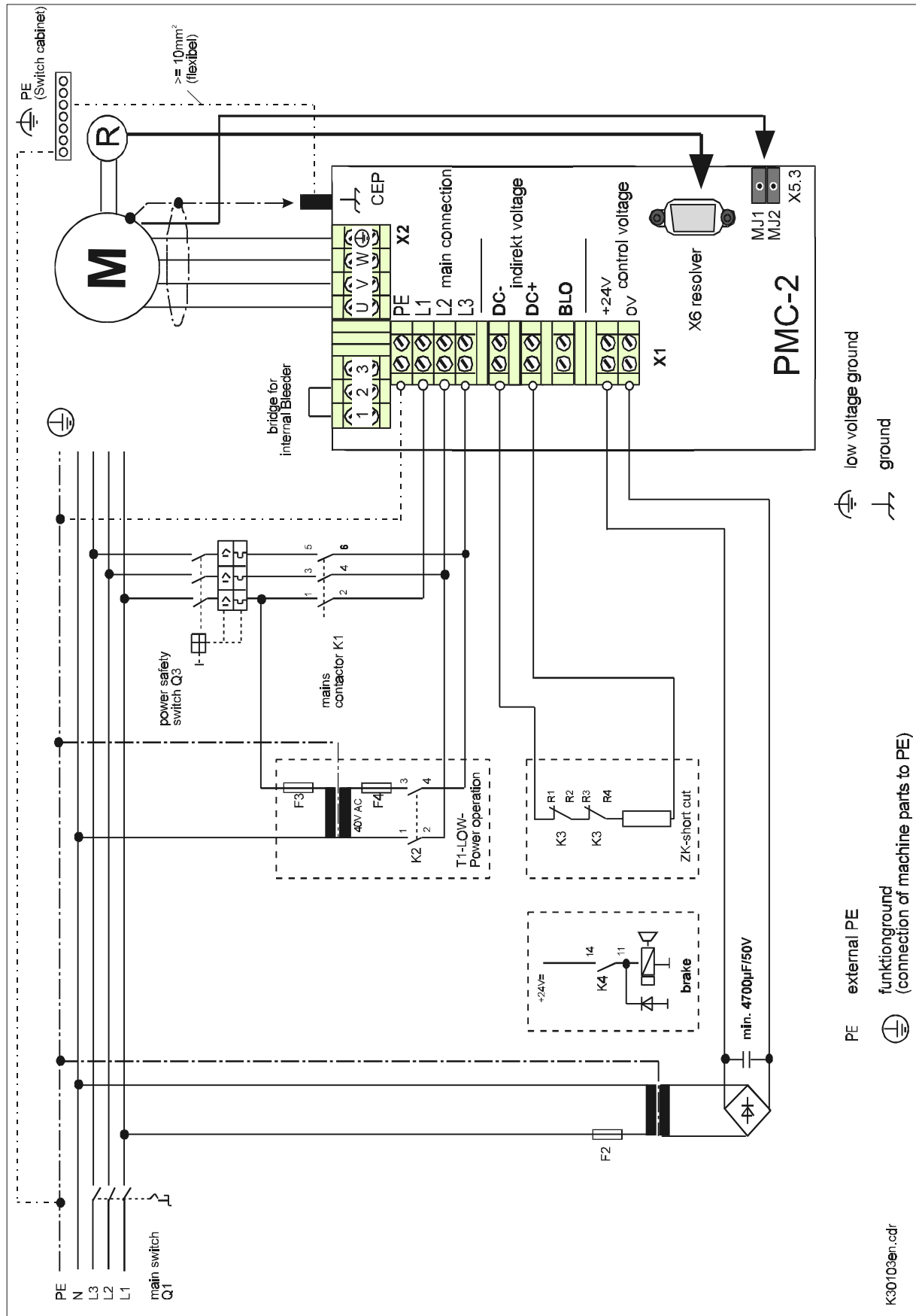

K30103en.cdr

7 Commissioning

We recommend urgently to call on ELAU personnel for the commissioning. This should not only be done for reasons of guaranty, but at the same time

- the equipment is controlled
- the optimal parameters are checked/determined
- the attendance crew will be instructed

7.1 Procedure

Data comparison

Compare the data of the PMC-2 positioning motor controller and of the SB-XXX servo motor on the basis of the type plates and the table "Combinations PMC-2 and SB-motors".

Resolver or SINCOS encoder

The PMC-2 positioning motor controller and the SB-XXX servo motors are both provided factory-set by ELAU. The measuring in of the resolver or SINCOS on the scene is therefore not necessary.

Check of cables and wiring

Identity with the valid ELAU connection plans. Please make sure that all binders are firmly tightened, that the required cross sections are laid, that the shielding has been correctly done and that there are no interruptions and short-circuits.

Check of mains voltage

3 AC 400Volt +15%/-10% with 50 to 60Hz

If there are mains voltages deviating from this, an autotransformer will help to adapt the voltage.

Check of 24V DC control voltage

22 - 33V DC

1. Switch on

Only lay the 24 Volt control voltage.

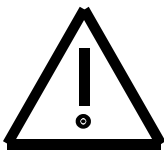

During the setting of parameters, there should only be the control voltage laid until meaningful parameters are fed into the PMC-2.

- BE-7 prompts for menu selection
- Status LEDs on the front panel

POW	green	on
TMP	red	off
ILI	red	off
WD	red	off
BLF	red	off
BLO	green	off
ERR	yellow	off

- If you do not receive these displays, please check the cause with the help of chapter 8 "Diagnosis and operation".

Check of the safety functions

- Motor thermo contact or PTC.
- As soon as the power connector is torn off the motor, the PMC-2 has to recognise this.
- Does the brake function, if present?
- Does the emergency stop chain function?
- Do the emergency stop limit switches function?

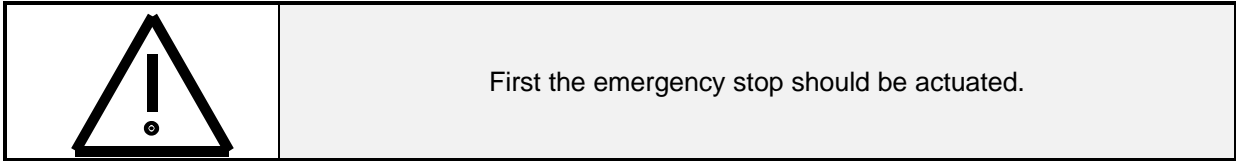
End of 1st commissioning**Lay of mains supply**

If all status displays are o.k., release the emergency stop.

Positioning of axis

For the first positioning of the axis choose "Manual operation slow"

- Caution! Check sense of rotation of axis.
- Check the software limit switch
- Brake distance check
 - Check of the hardware emergency stop limit switch.
 - The brake distance is checked in both directions.

After successful 1st commissioning of the PMC-2, lay now the mains supply.

7.2 List of parameter variables (P)

Parameter variables are data in which machine parameters and drive specific information are filed. The transfer of new parameters is done at the switch of enable. Parameters are power failure safe. They are filed into the Memory Module and are copied into the RAM memory with the switch on of the unit. When sending new parameters, an automatic copy is made from the RAM memory to the Memory Module.

7.2.1 General parameters

Number P	Designation	Unit	Data type	Access level	Min-Max	Default
0.00	Name_of_axis		text	Foreman		PMC-2
0.01	V_max	E/sec	I32	Foreman	0.1-99999.9	500.0
0.02	A_max	E/sec ²	I32	Foreman	1-99999	10000
0.03	A_quick_stop	E/sec ²	I32	Foreman	1-99999	10000
0.04	QStop_power_off		AT	Foreman	yes-no	yes
0.05	Man_slow	E/sec	I32	Foreman	0.1-99999.9	50.0
0.06	Man_quick	E/sec	I32	Foreman	0.1-99999.9	500.0
0.07	Accel_smooth	msec	I32	Foreman	0-1000	20
0.08	Homing_mode		I32	Foreman	0-7	0
0.09	V_Homing	E/sec	I32	Foreman	0.1-99999.9	50.0
0.10	Homing_switch		AT	Foreman	nor.-closed/nor.-open contact	normally-open contact
0.11	Limit_switch		AT	Foreman	nor.-closed/nor.-open contact	normally-closed contact
0.12	Positioning_mode		AT	Foreman	abs./endless	absolute
0.13	Softlimit_pos	E	I32	Foreman	+ -999999.999	1000.000
0.14	Softlimit_neg	E	I32	Foreman	+ -999999.999	-1000.000
0.15	0_point_offset	E	I32	Foreman	+ -999999.999	0
0.16	Time_DC_Short_Ci	msec	I32	Foreman	50-1000	100
0.17	Time_brake	msec	I32	Foreman	0-1000	100
0.18	Code_foreman		I32	Foreman	0-99999	1
0.19	Code_Installer		I32	Installer	0-99999	2
0.20	Language		AT	Foreman	Ger/Engl/French/Ital/Spain	German
0.21	COM2_application		AT	Foreman		no
0.22	COM2_address		I32	Foreman	0-255	1
0.23	LCD_contrast		I32	Foreman	0-32	25
0.24	PMC_Variant		AT	Foreman	standard/SINCOS	Standard
0.25	Bleeder		AT	Foreman	yes / no	yes
0.26	COM1_application		AT	Foreman		SINEC_L1_S
0.27	COM1_address		I32	Foreman	0 - 255	1
0.28	AUTO_cfg		BS	Foreman		00000000

7.2.2 Positioning control parameters

Number P	Designation	Unit	Data type	Access level	Min-Max	Default
1.00	Position_Kv		I32	Foreman	0.1-25.5	1.0
1.01	Following error	E	I32	Foreman	0-99999.999	50.000
1.02	Foll_error_time	msec	I32	Foreman	0-99999	100
1.03	Pos_window	E	I32	Foreman	0-99999.999	1.000
1.04	Pos_window_time	msec	I32	Foreman	0-99999	0
1.05	Position_encoder		I32	Foreman	0-1	0
1.06	free					
1.07	Ref_encoder		AT	Foreman	no-yes	no

7.2.3 Parameter group 2 - speed regulators

Number P	Designation	Unit	Data type	Access level	Min-Max	Default
2.00	V_P_gain		I32	Foreman	0-200	30
2.01	V_I_time		I32	Foreman	0-2500	100
2.02	V_feed_forward	%	I32	Foreman	0-120	100
2.03	Filter_Param.1	msec	I32	Foreman	0.0-10.0	0.5
2.04	Filter_Param.2	msec	I32	Foreman	0.0-10.0	0.5

7.2.4 Parameter group 3 - encoder data

Number P	Designation	Unit	Data type	Access level	Min-Max	Default
3.00	Resolution_enc_0	I/E	I32	Foreman	0.0001-9999.9999	100.0000
3.01	Incr_encoder_0	Increm	I32	Foreman	1-999999	8192
3.02	Pol_couple_reslover		I32	Foreman	1-4	1
3.03	Resolution_enc_1	I/E	I32	Foreman	0.0001-9999.9999	100.0000
3.04	Incr_encoder_1	Increm	I32	Foreman	1-99999999	4096
3.05	Rotations_1		I32	Foreman	1-16535	1
3.06	Pulses_encoder_1		I32	Foreman	8-32	26
3.07	Frequence_enc_1	kHz	AT	Foreman	62/125/250/500	250
3.08	Encoder_direct_1		AT	Foreman	neg/pos	pos
3.09	Resolution_enc_2	I/G	I32	Foreman	0.0001-9999.9999	100.0000
3.10	Incr_encoder_2	Increm	I32	Foreman	1-99999999	4096
3.11	Rotations_2		I32	Foreman	1-16535	1
3.12	Pulses_encoder_2		I32	Foreman	8-32	26
3.13	Frequence_enc_2	kHz	AT	Foreman	62/125/250/500	250
3.14	Encoder_direct_2		AT	Foreman	neg/pos	pos
3.15	Norm_encoder		I32	Foreman	0-2	0

7.2.5 Parameter group 4 - motor data

Number P	Designation	Unit	Data type	Access level	Min-Max	Default
4.00	Motor_type		Text	Foreman		default
4.01	Motor_direction		AT	Foreman	neg/pos	pos
4.02	Max_current	mA	I32	Foreman	0-50000	2000
4.03	Maximum_RPM	RPM	I32	Foreman	1-8000	3600
4.04	No_of_poles		I32	Installer	1-6	4
4.05	Torque_const.	Ncm/A	I32	Installer	0-99999	151
4.06	W_resistance	mOhm	I32	Installer	1-999999	12093
4.07	W_inductivity	mH	I32	Installer	1-999999	23.975
4.08	Nominal_power	mA	I32	Installer	0-250000	500
4.09	J_internal	kg cm ²	I32	Foreman	0.001-200.000	1.900
4.10	J_ex_internal		I32	Foreman	0-99.9	1.0
4.11	I_P_gain		I32	Foreman	1-999	1000
4.12	I_I_time		I32	Foreman	0-99999	100
4.13	I_feed_forward	%	I32	Foreman	0-120	100

7.2.6 Parameter group 5 - setup

Number P	Designation	Unit	Data type	Access level	Min-Max	Default
5.00	Wiring		VTAB	Foreman		see 8.6.2
5.01	TEST_switches		BS	R&D		00000000
5.02	I_Group_0		AT	Foreman		PMC X4.2
5.03	I_Group_1		AT	Foreman		RAM
5.04	I_Group_2		AT	Foreman		RAM
5.05	I_Group_3		AT	Foreman		RAM
5.06	I_Group_4		AT	Foreman		RAM
5.07	I_Group_5		AT	Foreman		RAM
5.08	I_Group_6		AT	Foreman		RAM
5.09	I_Group_7		AT	Foreman		RAM
5.10	I_Group_8		AT	Foreman		RAM
5.11	I_Group_9		AT	Foreman		RAM
5.12	O_Group_0		AT	Foreman		PMC X4.3
5.13	O_Group_1		AT	Foreman		RAM
5.14	O_Group_2		AT	Foreman		RAM
5.15	O_Group_3		AT	Foreman		RAM
5.16	O_Group_4		AT	Foreman		RAM
5.17	O_Group_5		AT	Foreman		RAM
5.18	O_Group_6		AT	Foreman		RAM
5.19	O_Group_7		AT	Foreman		RAM
5.20	O_Group_8		AT	Foreman		RAM
5.21	O_Group_9		AT	Foreman		RAM

7.2.7 Parameter group 6 - text for operational unit

Number P	Designation	Unit	Data type	Access level	Min-Max	Default
6.00	BE_Text			Foreman		
6.20	BE_Mode		AT	Foreman	1 - 5	BE_Mode_1

Number P	Variable	Display text	lower limit	upper limit	Format
6.00	V0000		0	0	0.0
6.01	V0001		0	0	0.0
6.02	V0002		0	0	0.0
6.03	V0003		0	0	0.0
6.04	V0004		0	0	0.0
6.05	V0005		0	0	0.0
6.06	V0006		0	0	0.0
6.07	V0007		0	0	0.0
6.08	V0008		0	0	0.0
6.09	V0009		0	0	0.0
6.10	V0010		0	0	0.0
6.11	V0011		0	0	0.0
6.12	V0012		0	0	0.0
6.13	V0013		0	0	0.0
6.14	V0014		0	0	0.0
6.15	V0015		0	0	0.0
6.16	V0016		0	0	0.0
6.17	V0017		0	0	0.0
6.18	V0018		0	0	0.0
6.19	V0019		0	0	0.0

7.2.8 Parameter group 7 - communication

Number P	Designation	Unit	Data type	Access level	Min-Max	Default
7.00	KOM_Mode		BS	Foreman		00000000
7.01	Start_Timeout		I32	Foreman	0 - 999999	10000
7.02	BUS_Timeout		I32	Foreman	0 - 999999	100
7.03	KOM_Timeout		I32	Foreman	0 - 999999	100
7.04	KOM_Address		I32	Foreman	0 - 999999	1

7.3 Direct parameter variables (Y)

Direct parameters are variables which, in contrast to normal parameters, are immediately taken over. Their purpose is to effect parameter changes in the ECL program. Direct parameters are initialised by corresponding parameters (after power on or after the transfer of new parameters -> enable LOW). When inscribing them, they are also limited to the parameter value.

Number Y	Designation	Unit	Data type	Access level	Min-Max	Default
00	max_current	mA	I32	Foreman	1-999999	P4.02
01	maximum_rpm	Rev/min	I32	Foreman	1-8000	P4.03
02	kv		I32	Foreman	1-100	P1.00
02	language		AT	Foreman	Ger/Engl./free	P0.20
04	direction		AT	Foreman	neg / pos	P4.01
05	v_gain	%	I32	Foreman	0-200	P4.10
06	v_feed_forward	%	I32	Foreman	0-100	P4-02

8 Diagnosis and operation

8.1 In general

The PMC-2 features a differentiated error treatment to enable of carefully directed reactions to certain events.

All errors and warnings have to be confirmed. Fatal errors of error class 1 can only be confirmed by a renewed switch off/on of the unit, if the cause of error is eliminated.

All errors and warnings are displayed as a three digit numbers and appear in clear text on the display of the BE-7 or in EPAS-3 respectively. The number consists of the error class as first digit and of the error number as second and third digit.

On the front plate of the PMC-2, there are 7 LEDs, which give first information on status and error in the unit.

WatchDog and outage of the logic voltage are no errors in the sense described above, but cause an immediate switch off of the unit.

8.2 LEDs and monitor outputs

Reset

MON 1

MON 2

POW

TMP

ILI

WD

BLF

BLA

ERR

Reset-button

Analog outputs
Via the system variables selection of the function:
MON 1: S3.00 "I_DAC_1_selection"
MON 2: S3.01 "I_DAC_2_selection"

The values are actualized with 1.5kHz.
(12 bit DA converter)

standardize for 10V:
current = PMC-2 peak current
speed = Motor speed (P4.03 / 1,2)
following error = 200% (100% = P1.01)

permanent light in normal status.
blinks, if bracom or output voltagages of the logic power supply (24V) are to small.
extingulshes, if bracing is missing.

lightens, if the internal temp of the PMC-2, motor or heat temperature are too high.

lightens, if the max. current in P4.02 (bzw. Y06) is reached or the I²t monitoring reacts.

lightens, if a hard error occurs. All outputs become inactive. -> Reset is necessary
(Watchdog)

lightens, if the bleeder current is to big or short circuit or bleeder resistor are not connected (or ZK-voltage is LOW).
(Bleeder error)

lightens, if intermediate circuit is discharged via bleeder (at braking of axis)
(Bleeder-activ)

lightens, if an error of class 1 - 4 occurs
(Error)
1 : fatal error -> Reset is necessary
2-4 : confirmation is possible

K60001en.cdr

8.3 List of all errors

Error class 1: Fatal error -> contact our service department

Error class 1	PMC-2 text	short explanation
110	Ojob timeout	internal error
120	Ampl. shortcircuit	high-level short circuit
131	Bleeder error	bleeder resistor defective
148	MEM no module	no MEM module plugged
149	MEM no parameter	no parameters on MEM module
163	Incomp. EPROMs	Incompatible EPROMs in POS and actuator
164	SW WatchDog MC/VC	SW watch dog in actuator part
165	VC fatal error	fatal SW error in actuator part
167	Wiring	Wiring table defective
171	Error encoder_1	hardware encoder error encoder_1
172	Error encoder_2	hardware encoder error encoder_2
176	EEprom Checksum	Check sum of Eeprom is wrong
177	Power Fail	Voltage loss
178	ECL Error 1	ECL ERROR-Instruction
195	Pole_number mot/res	wrong number of pole couples for motor or resolver
197	SINCOS_1	error with SINCOS as position encoder
198	SINCOS_2/INK_2	error with SINCOS or incremental encoder as target encoder and SINCOS as position encoder

Error class 2: bad errors -> Check unit, confer with our service department, if necessary

Error class 2	PMC-2 text	short explanation
207	Parameter inval	Parameter beyond limit values
209	SW_Error	unknown error number
211	Job Timeout	internal error
217	Default Param.	Default parameters loaded
221	Overcurrent	peak current of PMC-2 exceeded
223	DC-Bus high	Indirect tension too high
225	Motor temp high	Motor temperature too high
234	unknown error	error text not yet defined
241	Encoder not move	Encoder causes no change
242	Jumping Encoder	Position changes erratically
243	Error encoder_0	Error in resolver/SINCOS or cable connection
247	MEM CRC Error	Memory check sum error
258	BP_Ident	Break point is wrong
268	bad Encoder	Encoder not available or double assignment
269	> Max. Rotation	Speed too high
270	> Max. Current	Motor current in parameter too high
271	Error Encoder1	Hardware encoder error incremental encoder 1
273	Error Encoder2	Hardware encoder error incremental encoder 2
274	Err-SSI-Encoder2	Hardware encoder error absolute encoder 2
275	Param. > v_max	One parameter speed is higher than v_max
279	ECL Error 2	ECL ERROR-Instruction
291	8fold following error	8-fold following error occurred
293	Param < Omax	P0.03 O_quick_stop smaller than P0.02 O_max

Error class 3: normal errors -> remove error cause

Error class 3	PMC-2 text	short explanation
301	HW limit switch -	driven to neg. HW limit switch
302	HW limit switch +	driven to pos. HW limit switch
303	SW_limit switch -	driven to neg. software limit switch
304	SW_limit switch +	driven to pos. software limit switch
305	Following error	position_following error too big
312	Arithm. Overflow	ECL arithmetic over/underflow
313	Division by Zero	ECL division by zero
314	Time Overflow	ECL WAITT target time overrun
315	Linking Timeout	Time out at SPEED CONTOURING
335	Unval Home Mode	homing drive mode not valid
336	Lim_SW b. 0 Pulse	driven to limit switch before 0_pulse
337	No 0_Pulse/Rev	no reset pulse in one revolution
339	not homed	system has not homed
345	Sector invalid	sector number of the MEM module is not valid
346	MEM R/W Error	read-write error on the MEM_module
350	BCD Format Error	BCD transformation error
351	Variable Number	ECL wrong variable number
352	Variable Range	ECL value inadmissible
353	Stack Error	ECL max. UP-interlacing
354	Program Area	ECL tcb-id wrong task number
356	PGM Trans active	program transfer active
357	no valid Program	no valid program available
359	Vel <= 0	velocity too low
360	Vel too high	velocity to high
361	ACC<=0	acceleration too low
362	ACC too high	acceleration too high
366	Defect Data SYN	defective data in ECL SYN command
380	ECL Error 3	ECL ERROR-Instruction
383	ECL COM	ECL COM 2 application has no parameters
386	Pos Overflow	to large actual position
390	PLC-PT function	not allowed ECL instruction in PLC-PT

error class 4: light errors -> remove error cause

Error class 4	PMC-2 text	short explanation
416	P_Window Timeout	Target window time out
426	Heat Sink Temp	Dissipator temperature too high (level 2)
427	Inside Temp high	Internal temperature too high
430	Bleeder I2T	Bleeder resistor overstrained
481	ECL Error 4	ECL ERROR-Instruction

Warnings: -> These are normally only for your information, but they should nevertheless be removed

Warnings	PMC-2 text	short explanation
522	Power Line fail	Mains phase failure
524	DC-Bus low	Indirect tension too low
526	Dissipator Temp	Dissipator temperature high (level 1)
528	Motor I2T	Motor overstrained
529	Power Ampl. I2T	High level overstrained
582	ECL Error 5	ECL ERROR-Instruction
584	EEPROM ANA1	no balancing data for ANA-1
587	BE Timeout	no operational unit found
588	Cont.Voltage low	control voltage too low
589	Comm. module	Communications module error
592	EG following error	in SYN mode no synchronisation to SEP
596	Axis Pos Timeout	AXIS command ignored due to system overload

8.4 Chart with error reactions

Action	Error class	1	2	3	4	5
Mains separation The relay_output "Mains on" (normally-open contact) opens		yes	yes	no	no	no
High level deactivated no EMK braking		yes	yes	no	no	no
Brake active The relay_output "brake release" (normally-open contact) opens		yes	yes	no	no	no
Indirect short circuit The external discharging resistor, decelerated by P16 (time_DC_short circuit), switched via intermediate circuit. The relay_output "DC short circuit" (normally-open contact) opens		yes	yes	no	no	no
Ready for operation The output "Ready for operation" opens		off	on	on	on	on
Disturbance output The relay output "Error" (normally-closed contact) opens		on	on	on	on	off
Warning output The relay output "Warning" (normally-closed contact) opens		on	on	on	on	on
Drive immediate stop		yes	yes	yes	no	no
Stop at record end		x	x	no	yes	no
Acknowledgeable via acknowledge key		no	yes	yes	yes	yes
ECL stop		yes	yes	no	no	no
ECL PLC - PT stop		no	no	no	no	no
Reset outputs (P0.28 Auto_cfg = 00000000)		yes	yes	no	no	no

8.5 Variables

8.5.1 Access protection

There is a general mechanism for the control of the accesses to all variables. Each variable has an access authorisation for writing; reading, however, has no access protection. We differ between six authorisation levels:

Level	Meaning	Key	Key deposit
0	Operator	none	none
1	Foreman	Level1	Parameters
2	Installer	Level2	Parameters
3	Application	Level3	EPROM
4	R&D	Level4	EPROM
5	none	none	none

8.5.2 Variable types

There are the following variable types:

Variable type	Grammalogue	Number
Inputs	I	160
Outputs	O	160
User variables	V	10000
User flags	F	160
Parameters	P	see parameters
Direct parameters	Y	see direct parameters
System variables	S	see system variables

8.6 System variables (S)

Via system variable you have access to internal sizes.

There are the following data types of system variables:

- logical which can become the states high and low
- numerical which contain the corresponding numerical values
- enumeration type which have several states, e. g. 0, 1, 2 for the selection of options
- bit strings which contain codings or version numbers

We differ between input and output system variables. They are accordingly signed with I or O.

The designation of the variables is composed of the standard designation Sx.xx and of a symbolic name. In the EPAS-3 variable editor and in the display they appear with both designations, in the ECL it is referred to the variables with the standard designation.

The write access authorisation can be taken out of the listing. Basically, it is not possible to write on output system variables, neither can you write on input system variables, if there are wired on hardware inputs.

Logical system variables can be partly "wired". Wired means that they can be set on either an input or output, into the memory or to a firm value. It is therefore possible to effectively profit by the hardware I/Os. If, for example, the PMC-2 is always moved in the operating mode automatic, the input system variable "E_Auto" (S1.11) will be firmly wired on high which saves one input. The "wiring" can be achieved in EPAS-3. There is also a default assignment in the EPROM.

8.6.1 Not wirable logical system variables

Number S	Designation	Unit	Data type	Access level	Min-Max
0.00	O_drive_turns		Bool	Nobody	
0.01	O_pos_window		Bool	Nobody	
0.02	free		Bool	Nobody	
0.03	free		Bool	Nobody	
0.04	free		Bool	Nobody	
0.05	I_Start_Signal		Bool	Nobody	
0.06	O_brake		Bool	Nobody	
0.07	O_power_relay		Bool	Nobody	
0.08	O_DC_short_circ		Bool	Nobody	
0.09	O_T1_relay		Bool	Nobody	
0.10	I_control_enable		Bool	Nobody	
0.11	I_touchprobe_1		Bool	Nobody	
0.12	I_touchprobe_2		Bool	Nobody	
0.13	I_home_switch		Bool	Nobody	
0.14	Limitswitch_pos		Bool	Nobody	
0.15	Limitswitch_neg		Bool	Nobody	
0.16	I_motor_temp		Bool	Nobody	
0.17	I_emergency_off		Bool	Nobody	
0.18	I_IRQ1		Bool	Nobody	
0.19	I_IRQ2		Bool	Nobody	

8.6.2 Wirable logical system variables

Number S	Designation	Unit	Data type	Access level	Factory setup	
					Function	Number
1.00	O_manuell_active		Bool	Nobody	X4.3 DIG.OUT	1
1.01	O_auto_active		Bool	Nobody	X4.3 DIG.OUT	0
1.02	O_controller_ok		Bool	Nobody	X4.3 DIG.OUT	2
1.03	O_error		Bool	Nobody	X4.3 DIG.OUT	3
1.04	O_warning		Bool	Nobody	X4.3 DIG.OUT	4
1.05	O_Homed		Bool	Nobody	X4.3 DIG.OUT	6
1.06	O_Homing_active		Bool	Nobody	X4.3 DIG.OUT	7
1.07	O_Syn_active		Bool	Nobody	Memory	
1.08	O_TP1_active		Bool	Nobody	X4.3 DIG.OUT	5
1.09	O_TP2_active		Bool	Nobody	Memory	
1.10	I_Manuell		Bool	Foreman	X4.2 DIG.IN	1
1.11	I_Auto		Bool	Foreman	X4.2 DIG.IN	0
1.12	I_T1		Bool	Foreman	X4.2 DIG.IN	2
1.13	I_quick stop		Bool	Foreman	X4.2 DIG.IN	3
1.14	I_error_quitt		Bool	Foreman	X4.2 DIG.IN	4
1.15	I_man_positive		Bool	Foreman	X4.2 DIG.IN	5
1.16	I_man_negative		Bool	Foreman	X4.2 DIG.IN	6
1.17	I_man_homing		Bool	Foreman	X4.2 DIG.IN	7
1.18	I_fast_slow		Bool	Foreman	X4.2 DIG.IN	8
1.19	free		Bool	Foreman		
1.20	I_encoder_check		Bool	Foreman	Memory	
1.21	I_encoder_still		Bool	Foreman	Memory	
1.22	free		Bool	Foreman		
1.23	I_start_stop		Bool	Foreman	X4.2 DIG.IN	5
1.24	I_single		Bool	Foreman	X4.2 DIG.IN	6
1.25	I_PGM_0		Bool	Foreman	const. LOW	
1.26	I_PGM_1		Bool	Foreman	const. LOW	
1.27	I_PGM_2		Bool	Foreman	const. LOW	

8.6.3 System variables group 2

Number S	Designation	Unit	Data type	Access level	Min-Max
2.00	O_ref_current	mA	I32	Nobody	±999999
2.01	O_act_current	mA	I32	Nobody	±999999
2.02	O_ref_RPM's	Rev/min	I32	Nobody	±8000
2.03	O_act_RPM_s	Rev/min	I32	Nobody	±8000
2.04	O_ref_velocity	Unit/sec	I32	Nobody	±99999.9
2.05	O_act_velocity	Unit/sec	I32	Nobody	±99999.9
2.06	O_target_pos	Unit	I32	Nobody	±999999.999
2.07	O_act_position	Unit	I32	Nobody	±999999.999
2.08	O_ref_position	Unit	I32	Nobody	±999999.999
2.09	O_follow_error	Unit	I32	Nobody	±999999.999
2.10	O_act_position_0	Unit	I32	Nobody	±999999.999
2.11	O_act_position_1	Unit	I32	Nobody	±999999.99;
2.12	O_act_position_2	Unit	I32	Nobody	±999999.999
2.13	O_TP_1_position	Unit	I32	Nobody	±999999.999
2.14	O_TP_2_position	Unit	I32	Nobody	±999999.999
2.15	O_act_pos_encod		I32	Nobody	0,...,2
2.16	O_Job_active		Bool	Nobody	
2.17	O_i2t	%	I32	Nobody	0 ... 100
2.18	O_act_position_4	Unit	I32	Nobody	±999999.999
2.19	O_act_position_5	Unit	I32	Nobody	±999999.999

8.6.4 System variables group 3

Number S	Designation	Unit	Data type	Access level	Min-Max
3.00	I_DAW_1_select		A_type	Foreman	
3.01	I_DAW_2_select		A_type	Foreman	
3.02	I_analog_1_ANA-1		I32	Nobody	±99999.999
3.03	I_analog_2_ANA-1		I32	Nobody	±99999.999
3.04	I_analog_3_IKA-1		I32	Nobody	±99999.999
3.05	I_analog_4		I32	Nobody	±99999.999
3.06	O_analog_1_ANA-1		I32	Foreman	±99999.999
3.07	O_analog_2_ANA-1		I32	Foreman	±99999.999
3.08	O_analog_3_MON 1		I32	Foreman	±99999.999
3.09	O_analog_4_MON 1		I32	Foreman	±99999.999

8.6.5 System variables group 4

Number S	Designation	Unit	Data type	Access level	Min-Max
4.00	O_Act_error		I32	Nobody	0 - 599
4.01	O_Last_error		I32	Foreman	0 - 499
4.02	O_Last_warning		I32	Foreman	0 - 599
4.03	O_operating_mode		AT	Nobody	
4.04	O_PT_block_1		I32	Nobody	±9999
4.05	O_PT_block_2		I32	Nobody	±9999
4.06	O_PT_block_3		I32	Nobody	±9999
4.07	O_PT_block_4		I32	Nobody	±9999
4.08	O_PT_block_5		I32	Nobody	±9999
4.09	O_PT_block_6		I32	Nobody	±9999
4.10	O_PT_block_7		I32	Nobody	±9999
4.11	O_PT_block_8		I32	Nobody	±9999
4.12	O_PT_state_1		AT	Nobody	
4.13	O_PT_state_2		AT	Nobody	
4.14	O_PT_state_3		AT	Nobody	
4.15	O_PT_state_4		AT	Nobody	
4.16	O_PT_state_5		AT	Nobody	
4.17	O_PT_state_6		AT	Nobody	
4.18	O_PT_state_7		AT	Nobody	
4.19	O_PT_state_8		AT	Nobody	
4.20	O_PT_error_1		I32	Nobody	0 - 999
4.21	O_PT_error_2		I32	Nobody	0 - 999
4.22	O_PT_error_3		I32	Nobody	0 - 999
4.23	O_PT_error_4		I32	Nobody	0 - 999
4.24	O_PT_error_5		I32	Nobody	0 - 999
4.25	O_PT_error_6		I32	Nobody	0 - 999
4.26	O_PT_error_7		I32	Nobody	0 - 999
4.27	O_PT_error_8		I32	Nobody	0 - 999
4.28	O_PT_result_1		I32	Nobody	0 - 999
4.29	O_PT_result_2		I32	Nobody	0 - 999
4.30	O_PT_result_3		I32	Nobody	0 - 999
4.31	O_PT_result_4		I32	Nobody	0 - 999
4.32	O_PT_result_5		I32	Nobody	0 - 999
4.33	O_PT_result_6		I32	Nobody	0 - 999
4.34	O_PT_result_7		I32	Nobody	0 - 999
4.35	O_PT_result_8		I32	Nobody	0 - 999
4.36	O_Pgm_name		Text	Nobody	
4.37	O_Pgm_Ok		I32	Nobody	0 - 999
4.38	O_Pgm_blocks		I32	Nobody	0 - 9999
4.39	O_Pgm_ZC		I32	Nobody	0 - 99999
4.40	O_Pgm_code		I32	Nobody	0 - 999999
4.41	O_Task-comm._No.		I32	Nobody	0 - 99999
4.42	O_user_timer	msec	I32	Nobody	0 - 999999999
4.43	O_FLASH_map		BS	Nobody	00000000 - FFFFFFFF
4.44	O_Akt_errortext		Text	Nobody	
4.45	O_COM_send		I32	Nobody	±256
4.46	O_COM_receive		I32	Nobody	±256
4.47	I_PMC_Reset		Bool	Foreman	
4.48	O_COM1_send		I32	Nobody	±256
4.49	O_COM1_receive		I32	Nobody	±256

8.6.6 System variables group 5

Number S	Designation	Unit	Data type	Access level	Min-Max
5.00	I_SYN_counter		I32	Foreman	1,...,32767
5.01	I_SYN_denomin		I32	Foreman	1,...,32767
5.02	I_SYN_offset	Unit	I32	Foreman	±99999.999
5.03	I_SYN_period	Unit	I32	Foreman	0,...,999999.999
5.04	I_SYN_end	Unit	I32	Foreman	±999999.999
5.05	O_SYN_vel	Unit/sec	I32	Nobody	±99999.9
5.06	O_Counter_0		I32	Nobody	0,...,99999
5.07	O_Denomin_0		I32	Nobody	0,...,99999
5.08	O_Counter_1		I32	Nobody	0,...,99999
5.09	O_Denomin_1		I32	Nobody	0,...,99999
5.10	O_Counter_2		I32	Nobody	0,...,99999
5.11	O_Denominator_2		I32	Nobody	0,...,99999
5.12	I_VEL_OLeit	Unit/sec	I32	Foreman	±9999.999
5.13	I_VEL_OLage	Unit/sec	I32	Foreman	0.01 - 99999.99
5.14	I_Master_Filter		I32	Foreman	0 - 10
5.15	I_SYN_Stop_Pos	Unit	I32	Foreman	±999999.999
5.16	I_SYN_SA_Period	Unit	I32	Foreman	0,...,99999.999
5.17	A_EG_State		I32	Nobody	0 - 99
5.18	O_POS_OMaster	Unit	I32	Nobody	±999999.999
5.19	O_SYN_end_count		I32	Nobody	0 - 255
5.20	O_SYN_LA_period	Unit	I32	Nobody	0,...,999999.999
5.21	O_SYN_FA_period	Unit	I32	Nobody	0,...,999999.999

8.6.7 System variables group 6 - memory module

Number S	Designation	Unit	Data type	Access level	Min-Max
6.00	O_MEM_contents_0		Text	Nobody	
6.01	O_MEM_contents_1		Text	Nobody	
6.02	O_MEM_contents_2		Text	Nobody	
6.03	O_MEM_contents_3		Text	Nobody	
6.04	O_MEM_contents_4		Text	Nobody	
6.05	O_MEM_contents_5		Text	Nobody	
6.06	O_MEM_contents_6		Text	Nobody	
6.07	O_MEM_contents_7		Text	Nobody	

8.6.8 System variables group 7 - communication

Number S	Designation	Unit	Data type	Access level	Min-Max
7.00	O_BUS_State		I32	Nobody	-99 - +99
7.01	O_KOM_State		I32	Nobody	-99 - +99
7.02	O_KOM_Error		I32	Nobody	-999 - +999
7.03	O_KOM_Info1		BS	Nobody	4 Byte
7.04	O_KOM_Info2		BS	Nobody	4 Byte
7.05	O_FLB_Status		I32	Nobody	± 999 999 999
7.06	O_FLB_Data1		I16	Nobody	-32 768 - +32 767
7.07	O_FLB_Data2		I32	Nobody	± 999 999 999
7.08	I_FLB_Data1		I16	Foreman	-32 768 - +32 767
7.09	I_FLB_Data2		I32	Foreman	± 999 999 999

8.6.9 System variables group 8 - options

Number S	Designation	Unit	Data type	Access level	Min-Max
8.00	free				

8.6.10 System variables group 9

Number S	Designation	Unit	Data type	Access level	Min-Max
9.00	O_OD_version		I32	Nobody	0 - 9999
9.01	O_POS_version		I32	Nobody	0 - 999999
9.02	O_contr_version		I32	Nobody	0 - 9999
9.03	O_RHO		I32	Nobody	0 - 4096
9.04	O_STELL_state		I32	Nobody	0 - 10
9.05	O_STOP_state		I32	Nobody	0 - 10
9.06	O_Param_status		BS	Nobody	
9.07	O_PMC2_option		BS	Nobody	
9.08	I_MEM_adr		BS	R&D	
9.09	I_MEM_data		BS	R&D	
9.10	O_FATAL_file		Text	Nobody	
9.11	O_FATAL_line		I32	Installer	0 - 99999
9.12	O_STELL_OPT_X17		BS	Nobody	
9.13	O_STELL_OPT_X18		BS	Nobody	
9.14	O_POS_OPT_X19		BS	Nobody	
9.15	O_POS_OPT_X20		BS	Nobody	

9 Maintenance

Quick error recognition and eradication helps to reduce the related production stop to a minimum.

The diagnosis messages of the PMC-2, which can be read via EPAS-3 or the BE-7, enable well-aimed and efficient error detection.

In case of any trouble, defective components can be exchanged without problem to ensure that the trouble is cleared quickly and production can be resumed as soon as possible. This work must be carried out by qualified maintenance staff only.

In case you return the defective unit to the ELAU customer support, please fill the distortion report following this chapter.

 CAUTION	Only units with identical hardware configuration and identical software version may be exchanged
---	--

9.1 Spare parts, components

Stock keeping of spare parts:

To have the most important components on stock is an important prerequisite for the equipment to function and be ready for use at all times.

When ordering spare parts, please give us the following data:

- Article number:
- Article designation:
- Serial number:
- Software version:

You will find this data on the type plate of the equipment or in the system variables of the PMC-2.

Example: type plate

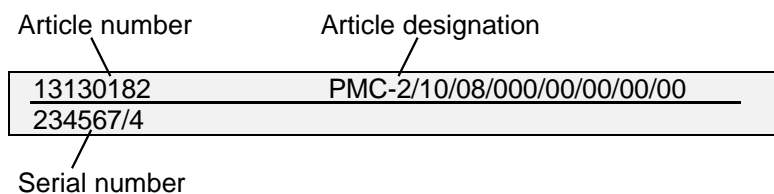

Example: software versions in the system variables

```
S9.01 A_POS_Version      200300
S9.02 A_STELL_Version    200300
```

9.2 Repairs

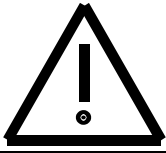

The return of components may only be done in the original or a comparable packaging. It is absolutely necessary that the components are packed in an ESD packaging or foil, since otherwise the claim for guarantee will expire.

For spare parts orders and repairs, please contact the following address:

ELAU AG
Address: Dillberg 12
97828 Marktheidenfeld
Postal address: Postfach 1255
97821 Marktheidenfeld
Telephone: 09391/606-0
Facsimile: 09391/606-300

9.2.1 Service

If you need a service engineer, please contact the following address:

ELAU AG
Postal address: Postfach 1255
97821 Marktheidenfeld
Service department / Application
Telephone: 09391/606-142

9.2.2 Unit exchange

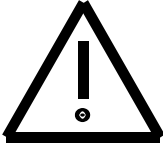
 CAUTION	<p>Risk of accident due to possibly fatal voltage!</p> <ol style="list-style-type: none">1. Before working at electrical installations, open main switch and secure against switch-on. <p>The drives must safely stand still because servo motors in generator operation may carry potentially fatal voltage on the motor cables.</p> <ol style="list-style-type: none">2. Do not separate plug connections which still carry a current.
---	--

CAUTION	<p>Static charge can damage the electronics of your PMC-2. Please pay attention to the following instructions in order to avoid possible damage:</p> <ol style="list-style-type: none">1. Do only touch the plate bars on its edges. Do not touch any connections or structural members.2. Before touching the plate bars make sure you reduce possible static charges. Touch an earthed metallic area such as the PMC-2 casing first.3. Do not lay the plate bars on a metallic surface.4. Move the plate bars as little as possible in order to avoid the creation of electrostatic charge due to clothes, carpets or furniture.
----------------	---

Exchanging the PMC-2

- open main switch
- secure against switch-on
-

 CAUTION	<p>ACHTUNG HOCHSPANNUNG! warning high voltage!</p> <p>Vor Arbeiten am Gerät, Netzanschluß trennen. Entladezeit > 1 min. disconnect from mains supply, before working on this equipment. Discharge time > 1 min</p>
---	--

- separate connecting cables from the PMC-2
- open screws on the top and bottom of the PMC-2; take the PMC-2 out
- insert the new PMC-2 and tighten the screws
- connect the new PMC-2 according to the machine switching plan
- In case a PMC-2 needs to be exchanged, this is normally possible without a PC. The memory module (MEM module) of the unit to be exchanged is simply plugged onto the new PMC-2. When switched on, the new unit thus has all the parameters, the program and the variables of the defective unit.

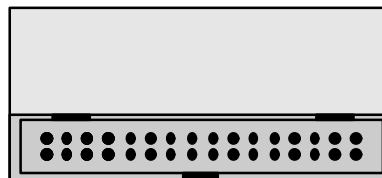

Note:

If the Memory Module of the PMC-2 is defective, you only have to change this element. For this, the parameters, the program, and the variables have to be fed again by means of EPAS-3 or the operational units.

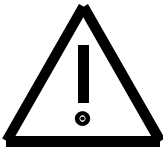
 CAUTION	<p>The MM15 may only be exchanged if the PMC-2 carries no voltage!</p>
---	--

- Put unit into operation again

Exchanging the motor

- open main switch
- secure against switch-on
- for mechanical exchange of the SB motor, observe manufacturer's instructions

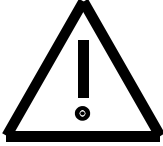
 CAUTION	<p>Risk of accident due to unintended axis movements. For servo axes with indirect track measuring system by motor encoder, the relation for measurement is lost if the motor is exchanged! Therefore the relation to the machine's coordinate system has to be restored after the exchange!</p>
---	--

- for indirect recording of actual position values by the motor's own measuring system, the relation for measurement has to be restored:
 - for motors with SINCOS encoders: see separate description
 - for motors with resolver: usually no adjustment is necessary

Exchanging cables

- open main switch
- secure against switch-on
- for exchanging cables, observe manufacturer's instructions

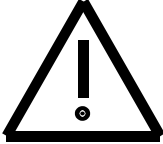
 CAUTION	<p>Risk of accident due to possibly fatal voltage. Disconnect or reconnect power connectors of the cables only if the plant is in voltage-free state!</p> <p>Connect power connectors only if both ends are dry and clean!</p> <p>If no ready commissioned cables from ELAU are used: Check the use of new cables for compatibility with the connection plan of the machine manufacturer!</p>
---	---

10 Technical data**10.1 PMC-2**

	general data
Input mains	
Nominal a.c. voltage	3 x 360 ... 460V (400V -10%/+15%)
Mains frequency	48 ... 62 Hz
Control voltage	22 ... 33V DC/2A (supply of logics)
Standard inputs	
Input voltage/power	20 ... 33V DC/5mA
Input filter standard	5ms
I-filter interrupt input	0.1ms
Motor protection	PTC or switch
Resolver	2-channel resolver
Standard outputs	
Digital outputs	20 ... 33V DC/0.1A
Relay outputs	60V DC/0.2A
2 monitor outputs	
<ul style="list-style-type: none"> • use • output voltage • output power • tolerance • resolution • updating time • system variables 	regulator adjustment, commissioning and diagnosis +/- 10V max. 3mA ±2% 12 bit 1.3 msec MON1 -> S3.08 MON2 -> S3.09
Communication	
Standard	2 RS 232/485 with SINEC L1
Option	field bus interface via option module
Pluggable option modules	
max. number	4 pieces
X11	FLB-1
X12 encoder	SCI-1, IKA-1 or INK-1
X13 communication	IBS-2 or DPS-1
X14 analog I/O	ANA-1
Operation conditions	
Ambient temperature with nominal data	+ 5°C to + 45°C
Storage temperature	- 20°C to + 70°C
Air humidity	Class F according to DIN 40040
System of protection	IP20

	PMC-2/2	PMC-2/4	PMC-2/5	PMC-2/8	PMC-2/16	PMC-2/25
Motor controller						
Nominal current (root mean square) Inc	2A	4A	5A	8A	16A	25A
Peak current (root mean square for 1 sec) Isc	4A	8A	10A	16A	32A	50A
Nominal output	1.3kVA	2.8kVA	3.4kVA	5.5kVA	11kVA	17kVA
	235µF	235µF	235µF	470µF	940µF	940µF
Cycle frequency	12kHz					
Rpm	0 ... +/- 6000 rpm					
Short circuit resistant	yes					
Earth contact resistant	yes					
Overstrain resistant	yes					
DC-circuit tension	510 ... 650V DC (735 V DC)					
Connection external bleeder	available					
U _{Bleeder} ON	approx. 735V					
U _{Bleeder} OFF	approx. 700V					
Resistance bleeder	47Ω	47Ω	47Ω	27Ω	only external Bleeder	only external Bleeder
Continuous operation bleeder	250W	250W	250W	250W	≥13.5Ω	≥10Ω
Peak power bleeder	5kW	5kW	5kW	8kW	16kW	22kW
Stray power with nominal current (incl. power pack, without bleeder stray power)	80W	110W	130W	180W	310W	480W
Fuse F1 (Control voltage)	2.5 A T	2.5 A T	2.5 A T	2.5 A T	2.5 A T	2.5 A T
Weight	approx. 6.5 kg	approx. 6.5 kg	approx. 8.0 kg	approx. 8.0 kg	approx. 12.5 kg	approx. 12.5 kg

10.2 Combinations PMC-2 and SB-motors

Definitions

M_{OM}	[Nm]	Standstill torque of the motor Constant torque (100% ED) with speed n_0 . With an ambient temperature of 40°C, an excess temperature of 60°C on the motor case in dependence of the thermal motor time constant will appear.
M_{NM}	[Nm]	Nominal torque of the motor Constant torque (100% ED) with nominal speed n_N . It is smaller than M_0 as a result of the speed-dependant losses. With an ambient temperature of 40°C, an excess temperature of 60°C on the motor case in dependence of the thermal motor time constant will appear.
M_{OD}	[Nm]	Standstill torque of the drive Constant torque (100% ED) with speed n_0 . With an ambient temperature of 40°C, an excess temperature of 60°C on the motor case in dependence of the thermal motor time constant will appear.
M_{ND}	[Nm]	Nominal torque of the drive Constant torque (100% ED) with nominal speed n_N . It is smaller than M_0 as a result of the speed-dependant losses. With an ambient temperature of 40°C, an excess temperature of 60°C on the motor case in dependence of the thermal motor time constant will appear.
M_{SD}	[Nm]	Peak torque of the drive (motor in combination with PMC-2)
I_{NC}	[A]	Rated current of PMC-2 Controller rated current (continuous operation S1).
I_{SC}	[A]	Peak current of the PMC-2 Peak current of controller for acceleration procedures. At the same time effective value for motor current at peak torque M_{SD} that is provided by the drive combination for a short term.
P4.02	[A]	Parameter value "max_current" for the combination motor - PMC-2.
P4.08	[A]	Parameter value "nom_current" for the combination motor - PMC-2.
n_{NM}	[1/min]	Nominal speed of the motor Usable speed at nominal torque. The idle running speed n_L and the maximum mechanical limit speed n_{Limit} of the servo motor are higher.
R_{W100}	[Ω]	Resistance of a motor winding Resistance of a motor winding between a phase and neutral point with an ambient temperature of 100°C.
K_{M100}	[Nm/A]	Torque constant of the motor (at 100°C motor temperature) Ratio of standstill torque M_0 and standstill current I_{0M} .
J_M	[kgcm ²]	Moment of inertia The motor's moment of inertia refers to a motor with resolver, but without brake.
P_{ND}	[kW]	Rated power of motor in combination with PMC-2.

PMC-2/02

I_{NC} = 2A
 I_{SC} = 4A

$T_{ambient}$ = 40°C
 ΔT_{Case} = 60°C

Motor type	M_{OM}	M_{NM}	M_{OD}	M_{ND}	M_{SD}	n_{NM}	R_{W100}	K_{M100}	J_M	P_{ND}	P4.02	P4.08
	Nm	Nm	Nm	Nm	Nm	1/min	Ω	Nm/A	kgcm ²	kW	A	A
SB 0565006	0.78	0.67	0.78	0.67	3.31	5000	29.230	0.92	0.21	0.35	3.6	0.732
SB 0704005	0.68	0.65	0.68	0.65	2.84	4000	59.709	1.09	0.26	0.27	2.7	0.614
SB 0704010	1.25	1.14	1.25	1.14	4.35	4000	20.888	1.12	0.40	0.48	4	1.044
SB 0704015	1.71	1.49	1.71	1.49	4.42	4000	12.809	1.14	0.54	0.62	4	1.343
SB 0704020	2.22	1.85	2.22	1.85	4.48	4000	8.539	1.16	0.68	0.77	4	1.653
SB 0706005	0.68	0.61	0.68	0.61	2.84	6000	28.376	0.75	0.26	0.38	3.9	0.840
SB 0706010	1.24	0.99	1.24	0.99	3.02	6000	10.313	0.78	0.40	0.62	4	1.315
SB 0706015	1.70	1.22	1.51	1.22	3.02	6000	6.043	0.78	0.54	0.77	4	1.611
SB 0706020	2.21	1.40	1.58	1.40	3.17	6000	4.270	0.82	0.68	0.88	4	1.774
SB 1052002	2.94	2.88	2.94	2.88	8.41	2000	25.092	2.17	1.9	0.60	4	1.368
SB 1052004	5.23	5.01	4.35	4.35	8.70	2000	9.623	2.25	3.4	0.91	4	2
SB 1053002	2.95	2.82	2.93	2.82	5.86	3000	12.093	1.51	1.9	0.89	4	1.923
SB 1054002	2.95	2.72	2.23	2.23	4.46	4000	7.035	1.15	1.9	0.93	4	2

PMC-2/04

I_{NC} = 4A
 I_{SC} = 8A

$T_{ambient}$ = 40°C
 ΔT_{Case} = 60°C

Motor type	M_{OM}	M_{NM}	M_{OD}	M_{ND}	M_{SD}	n_{NM}	R_{W100}	K_{M100}	J_M	P_{ND}	P4.02	P4.08
	Nm	Nm	Nm	Nm	Nm	1/min	Ω	Nm/A	kgcm ²	kW	A	A
SB 0565006	0.78	0.67	0.78	0.67	3.31	5000	29.230	0.92	0.21	0.35	3.6	0.732
SB 0704005	0.68	0.65	0.68	0.65	2.84	4000	59.709	1.09	0.26	0.27	2.7	0.614
SB 0704010	1.25	1.14	1.25	1.14	5.44	4000	20.888	1.12	0.40	0.48	5	1.044
SB 0704015	1.71	1.49	1.71	1.49	6.63	4000	12.809	1.14	0.54	0.62	6	1.343
SB 0704020	2.22	1.85	2.22	1.85	8.97	4000	8.539	1.16	0.68	0.77	8	1.653
SB 0706005	0.68	0.61	0.68	0.61	2.84	6000	28.376	0.75	0.26	0.38	3.9	0.840
SB 0706010	1.24	0.99	1.24	0.99	5.14	6000	10.313	0.78	0.4	0.62	6.8	1.315
SB 0706015	1.70	1.22	1.70	1.22	6.04	6000	6.043	0.78	0.54	0.77	8	1.611
SB 0706020	2.21	1.40	2.21	1.40	6.33	6000	4.270	0.82	0.68	0.88	8	1.774
SB 1052002	2.94	2.88	2.94	2.88	12.6	2000	25.092	2.17	1.9	0.60	6	1.368
SB 1052004	5.23	5.01	5.23	5.01	17.4	2000	9.623	2.25	3.4	1.05	8	2.304
SB 1052006	7.23	6.82	7.23	6.82	17.8	2000	5.820	2.30	4.8	1.43	8	3.061
SB 1052008	9.19	8.57	9.13	8.57	18.3	2000	4.210	2.36	6.2	1.79	8	3.752
SB 1053002	2.95	2.82	2.95	2.82	10.3	3000	12.093	1.51	1.9	0.89	7	1.923
SB 1053004	5.23	4.79	5.23	4.79	11.9	3000	4.473	1.53	3.4	1.50	8	3.230
SB 1054002	2.95	2.72	2.95	2.72	8.91	4000	7.035	1.15	1.9	1.14	8	2.440
SB 1054004	5.25	4.51	4.56	4.51	9.13	4000	2.627	1.18	3.4	1.89	8	3.950

PMC-2/05

I_{NC} = 5A
 I_{SC} = 10A

$T_{ambient}$ = 40°C
 ΔT_{Case} = 60°C

Motor type	M_{OM}	M_{NM}	M_{OD}	M_{ND}	M_{SD}	n_{NM}	R_{W100}	K_{M100}	J_M	P_{ND}	P4.02	P4.08
	Nm	Nm	Nm	Nm	Nm	1/min	Ω	Nm/A	kgcm ²	kW	A	A
SB 0704005	0.68	0.65	0.68	0.65	2.84	4000	59.709	1.09	0.26	0.27	2.7	0.614
SB 0704010	1.25	1.14	1.25	1.14	5.44	4000	20.888	1.12	0.40	0.48	5	1.044
SB 0704015	1.71	1.49	1.71	1.49	6.63	4000	12.809	1.14	0.54	0.62	6	1.343
SB 0704020	2.22	1.85	2.22	1.85	8.97	4000	8.539	1.16	0.68	0.77	8	1.653
SB 0706005	0.68	0.61	0.68	0.61	2.84	6000	28.376	0.75	0.26	0.38	3.9	0.840
SB 0706010	1.24	0.99	1.24	0.99	5.14	6000	10.313	0.78	0.4	0.62	6.8	1.315
SB 0706015	1.70	1.22	1.70	1.22	6.80	6000	6.043	0.78	0.54	0.77	9	1.611
SB 0706020	2.21	1.40	2.21	1.40	7.91	6000	4.270	0.82	0.68	0.88	10	1.774
SB 1052002	2.94	2.88	2.94	2.88	12.62	2000	25.092	2.17	1.9	0.60	6	1.368
SB 1052004	5.23	5.01	5.23	5.01	19.57	2000	9.623	2.25	3.4	1.05	9	2.304
SB 1052006	7.23	6.82	7.23	6.82	22.29	2000	5.820	2.30	4.8	1.43	10	3.061
SB 1052008	9.19	8.57	9.19	8.57	22.83	2000	4.210	2.36	6.2	1.79	10	3.752
SB 1053002	2.95	2.82	2.95	2.82	10.25	3000	12.093	1.51	1.9	0.89	7	1.923
SB 1053004	5.23	4.79	5.23	4.79	14.83	3000	4.473	1.53	3.4	1.50	10	3.230
SB 1053006	7.21	6.38	7.21	6.38	14.83	3000	2.588	1.53	4.8	2.00	10	4.302
SB 1053008	9.14	7.86	7.41	7.41	14.83	3000	1.793	1.53	6.2	2.33	10	5
SB 1054002	2.95	2.72	2.95	2.72	10.03	4000	7.035	1.15	1.9	1.14	9	2.440
SB 1054004	5.25	4.51	5.25	4.51	11.41	4000	2.627	1.18	3.4	1.89	10	3.950
SB 1054006	7.22	5.79	5.93	5.79	11.87	4000	1.655	1.22	4.8	2.43	10	4.878

PMC-2/08

I_{NC} = 8A
 I_{SC} = 16A

$T_{ambient}$ = 40°C
 ΔT_{Case} = 60°C

Motor type	M_{OM}	M_{NM}	M_{OD}	M_{ND}	M_{SD}	n_{NM}	R_{W100}	K_{M100}	J_M	P_{ND}	P4.02	P4.08
	Nm	Nm	Nm	Nm	Nm	1/min	Ω	Nm/A	kgcm ²	kW	A	A
SB 1052002	2.94	2.88	2.94	2.88	12.62	2000	25.092	2.17	1.9	0.60	6	1.368
SB 1052004	5.23	5.01	5.23	5.01	19.57	2000	9.623	2.25	3.4	1.05	9	2.304
SB 1052006	7.23	6.82	7.23	6.82	26.74	2000	5.820	2.30	4.8	1.43	12	3.061
SB 1052008	9.19	8.57	9.19	8.57	31.96	2000	4.210	2.36	6.2	1.79	14	3.752
SB 1053002	2.95	2.82	2.95	2.82	10.25	3000	12.093	1.51	1.9	0.89	7	1.923
SB 1053004	5.23	4.79	5.23	4.79	17.80	3000	4.473	1.53	3.4	1.50	12	3.230
SB 1053006	7.21	6.38	7.21	6.38	23.73	3000	2.588	1.53	4.8	2.00	16	4.302
SB 1053008	9.14	7.86	9.14	7.86	23.73	3000	1.793	1.53	6.2	2.47	16	5.303
SB 1054002	2.95	2.72	2.95	2.72	10.03	4000	7.035	1.15	1.9	1.14	9	2.440
SB 1054004	5.25	4.51	5.25	4.51	18.26	4000	2.627	1.18	3.4	1.89	16	3.950
SB 1054006	7.22	5.79	7.22	5.79	18.98	4000	1.655	1.22	4.8	2.43	16	4.878
SB 1054008	9.14	6.92	9.14	6.92	18.98	4000	1.150	1.22	6.2	2.90	16	5.829
SB 1452008	10.74	10.35	10.74	10.35	33.94	2000	3.547	2.19	10.5	2.17	16	4.877
SB 1452015	19.01	17.75	18.33	17.75	36.66	2000	1.478	2.37	16.0	3.72	16	7.745
SB 1453008	10.92	10.11	10.92	10.11	22.72	3000	1.537	1.47	10.5	3.18	16	7.119

PMC-2/16

I_{NC} = 16A
 I_{SC} = 32A

$T_{ambient}$ = 40°C
 ΔT_{Case} = 60°C

Motor type	M_{OM}	M_{NM}	M_{OD}	M_{ND}	M_{SD}	n_{NM}	R_{W100}	K_{M100}	J_M	P_{ND}	P4.02	P4.08
	Nm	Nm	Nm	Nm	Nm	1/min	Ω	Nm/A	kgcm ²	kW	A	A
SB 1452008	10.74	10.35	10.74	10.35	36.06	2000	3.547	2.19	10.5	2.17	17	4.877
SB 1452015	19.01	17.75	19.01	17.75	64.16	2000	1.478	2.37	16.0	3.72	28	7.745
SB 1452022	27.84	25.57	27.84	25.57	73.32	2000	0.782	2.37	21.5	5.36	32	11.157
SB 1452028	34.30	30.51	34.30	30.51	75.91	2000	0.598	2.45	27.0	6.39	32	12.863
SB 1453008	10.92	10.11	10.92	10.11	36.93	3000	1.537	1.47	10.5	3.18	26	7.119
SB 1453015	18.97	16.37	18.97	16.37	49.76	3000	0.683	1.61	16.0	5.14	32	10.526
SB 1453022	26.39	21.47	24.88	21.47	49.76	3000	0.401	1.61	21.5	6.75	32	13.807
SB 1454008	10.70	9.04	10.70	9.04	31.34	4000	0.762	1.01	10.5	3.79	32	9.230
SB 1454015	19.45	13.60	16.96	13.60	33.93	4000	0.302	1.10	16.0	5.70	32	12.826
SB 2051027	34.23	33.67	34.23	33.67	125.1	1000	2.174	4.04	50	3.53	32	8.612
SB 2051050	60.80	59.48	60.80	59.48	125.1	1000	0.775	4.04	80	6.23	32	15.216
SB 2052027	34.29	32.92	33.21	32.92	66.42	2000	0.611	2.14	50	6.89	32	15.858

PMC-2/25

I_{NC} = 25A
 I_{SC} = 50A

$T_{ambient}$ = 40°C
 ΔT_{Case} = 60°C

Motor type	M_{OM}	M_{NM}	M_{OD}	M_{ND}	M_{SD}	n_{NM}	R_{W100}	K_{M100}	J_M	P_{ND}	P4.02	P4.08
	Nm	Nm	Nm	Nm	Nm	1/min	Ω	Nm/A	kgcm ²	kW	A	A
SB 1452008	10.74	10.35	10.74	10.35	36.06	2000	3.547	2.19	10.5	2.17	17	4.877
SB 1452015	19.01	17.75	19.01	17.75	64.16	2000	1.478	2.37	16	3.72	28	7.745
SB 1452022	27.84	25.57	27.84	25.57	91.66	2000	0.782	2.37	21.5	5.36	40	11.157
SB 1452028	34.30	30.51	34.30	30.51	111.5	2000	0.598	2.45	27	6.39	47	12.863
SB 1453008	10.92	10.11	10.92	10.11	36.93	3000	1.537	1.47	10.5	3.18	26	7.119
SB 1453015	18.97	16.37	18.97	16.37	63.76	3000	0.683	1.61	16	5.14	41	10.526
SB 1453022	26.39	21.47	26.39	21.47	77.76	3000	0.401	1.61	21.5	6.75	50	13.807
SB 1453028	35.27	26.95	35.27	26.95	77.76	3000	0.243	1.61	27	8.47	50	17.331
SB 1454008	10.70	9.04	10.70	9.04	36.24	4000	0.762	1.01	10.5	3.79	37	9.230
SB 1454015	19.45	13.60	19.45	13.60	53.01	4000	0.302	1.10	16	5.70	50	12.826
SB 1454022	26.09	14.86	26.09	14.86	53.91	4000	0.197	1.11	21.5	6.22	50	13.777
SB 2051027	34.23	33.67	34.23	33.67	125.1	1000	2.174	4.04	50	3.53	32	8.612
SB 2051050	60.80	59.48	60.80	59.48	195.5	1000	0.775	4.04	80	6.23	50	15.216
SB 2051070	82.76	80.23	82.76	80.23	201.8	1000	0.476	4.17	110	8.40	50	19.880
SB 2051090	104.88	101.02	97.73	97.73	195.5	1000	0.309	4.04	140	10.23	50	25
SB 2052027	34.29	32.92	34.29	32.92	103.8	2000	0.611	2.14	50	6.89	50	15.858
SB 2052050	61.17	56.75	55.05	55.05	110.1	2000	0.243	2.27	80	11.53	50	25
SB 2053027	34.38	31.59	33.70	31.59	67.40	3000	0.256	1.39	50	9.92	50	23.433
SB 2053050	60.03	51.03	36.62	36.62	73.25	3000	0.112	1.51	80	11.50	50	25

11 Appendix

11.1 Declaration by the manufacturer

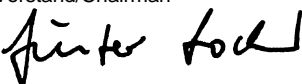
	Herstellereklärung / Declaration by the manufacturer / Déclaration du fabricant	ELN 102-04/06.97 Seite 1/1
Produkt : Positioniermotorcontroller PMC-2 / 11 / 02 PMC-2 / 11 / 05 PMC-2 / 11 / 08 PMC-2 / 11 / 16 PMC-2 / 11 / 25	product: Positioniermotorcontroller PMC-2 / 11 / 02 PMC-2 / 11 / 05 PMC-2 / 11 / 08 PMC-2 / 11 / 16 PMC-2 / 11 / 25	produit: Positioniermotorcontroller PMC-2 / 11 / 02 PMC-2 / 11 / 05 PMC-2 / 11 / 08 PMC-2 / 11 / 16 PMC-2 / 11 / 25
Der Hersteller erklärt, daß das gelieferte Produkt in Übereinstimmung mit den angewendeten harmonisierten Normen / Spezifikationen hergestellt worden ist.	The manufacturer declares that the product delivered has been manufactured in accordance with the stated harmonized standards / specifications.	Le fabricant déclare que le produit livrés ont été fabriqués conformément a indiqués standards / spécifications harmonisés.
Angewendete harmonisierte Normen: EN 60204-1 Sicherheit von Maschinen - elektrische Ausrüstung EN 50081-2 Fachgrundnorm für die Störaussendung pr EN 50082-2 Fachgrundnorm Störfestigkeit	Applied harmonized standards: EN 60204-1 Safety of machines - electrical equipment EN 50081-2 generic standard for noisy emission pr EN 50082-2 generic standard interference-resistant Manufacturer: ELAU AG Dillberg 12 D-97828 Marktheidenfeld	Harmonisée standards appliqués: EN 60204-1 Sécurité des machines-équipement électrique EN 50081-2 norme générique pour l'émission brouillée pr EN 50082-2 norme générique résistance au brouillage
Hersteller: ELAU AG Dillberg 12 D-97828 Marktheidenfeld	Fabricant: ELAU AG Dillberg 12 D-97828 Marktheidenfeld	
Stellung im Betrieb / Position : Vorstand/Chairman  1.6.1997 Günter Locher (Datum, Date / Unterschrift, Signature)		

	<p align="center">Herstellereklärung / EC-Declaration by the manufacturer / CE-Déclaration du fabricant</p> <p align="center">im Sinne der EG-Maschinenrichtlinie 89/392 EWG, Anhang II Abschnitt B as defined by EC-machinery directive 89/392 EEC, Annexe II Section B conformément à la directive "CE" relative aux machines 89/392 CEE Annexe II Section B</p>	<p align="center">ELN 101-02/06.97</p> <p align="center">Seite 1/1</p>
<p>Das von uns gelieferte Produkt</p>	<p>The product delivered by our company</p>	<p>Le produit livré par notre société</p>
<p>AC-Servomotor</p> <p>SB-056 SB-070 SB 105 SB-145 SB-205</p>	<p>AC-Servomotor</p> <p>SB-056 SB-070 SB 105 SB-145 SB-205</p>	<p>AC-Servomotor</p> <p>SB-056 SB-070 SB 105 SB-145 SB-205</p>
<p>ist zum Einbau in eine Maschine bestimmt.</p>	<p>is intended to be incorporated into a machine.</p>	<p>est destiné à être installé dans une machine.</p>
<p>Die Inbetriebnahme ist solange untersagt, bis festgestellt wurde, daß die Maschine, in die dieses Produkt eingebaut werden soll, den Bestimmungen der EG-Richtlinie entspricht.</p>	<p>The product must not be operated until the machine into which this product is to be incorporated has been declared in conformity with the provisions of the directive.</p>	<p>La mise en service des composants est fortement déconseillée avant que la machine dans laquelle le produit sera installés n'ait été déclarée conforme aux dispositions de la directive.</p>
<p>Hersteller:</p> <p>ELAU AG Dillberg 12 D-97828 Marktheidenfeld</p>	<p>Manufacturer:</p> <p>ELAU AG Dillberg 12 D-97828 Marktheidenfeld</p>	<p>Fabricant:</p> <p>ELAU AG Dillberg 12 D-97828 Marktheidenfeld</p>
<p>Stellung im Betrieb / Position :</p>		
<p>Vorstand/Chairman</p>		
		
<p>1.6.1997 Günter Locher</p>		
<p>..... (Datum, Date / Unterschrift, Signature)</p>		

Appliance configuration according to EMV-instructions 89/336/EWG

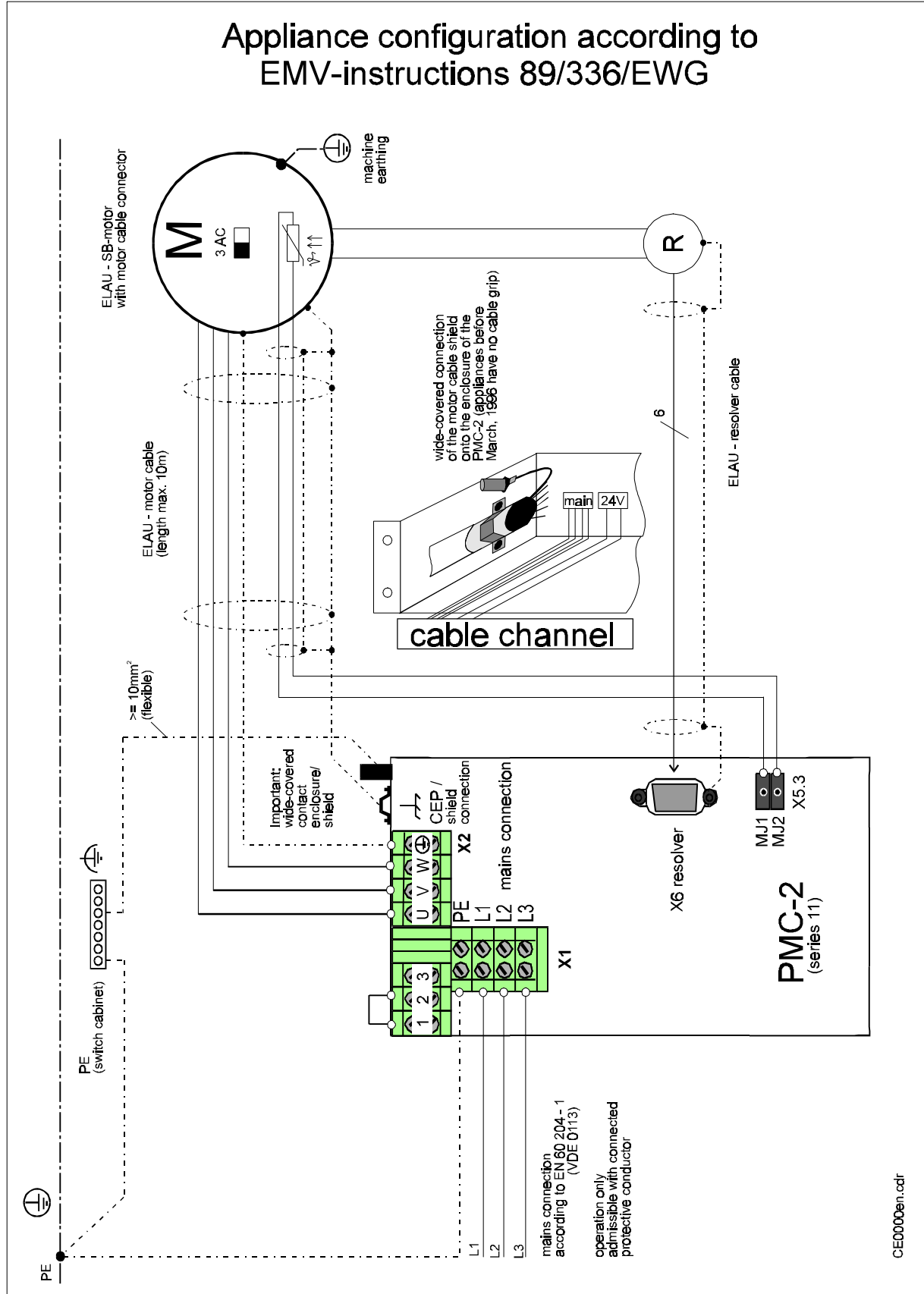

Instructions for the CE-certification of the appliance family PMC-2Mains connection

Mains connection is to be done in accordance with the instruction manual, chapter 3 „mounting and installation instructions“.

ELAU SB-motor

Earth the ELAU SB-motor on the machine via motor enclosure.

ELAU motor cable

On the motor side the motor cable shield is connected to the motor casing via the casing of the power connector. On the appliance side the shield of the motor cable is to be connected on a large surface to the casing of the appliance. Use the cable fixing on the top of the appliance.

CAUTION

No additional measures are required for cable lengths up to 10m. For motor cable lengths longer than 10m, additional interference suppression measures are necessary (mains filter, motor filter).

ELAU resolver cable

With the ELAU resolver cable, the shield connection on the motor side is done via a contact of the resolver cable. On the PMC-2 the shield is connected to the casing via metal case of the D-sub-connector.

other interfaces (COM, INK, SSI, ...)

For all other interfaces see the instructions in accordance with the chapter 4 Instruction Manual „Interfaces“.

11.2 Modifications

01/97

- Instruction manual was adapted to V20

07/97

- **1.8 Motors** SB 056 50 06 was newly added
- **3. Installation notes** was revised
- **4.8 Motor connector** SINCOS was added
- **5. Wiring of the PMC-2 in the system** was revised
- **7.3 List of all errors** was revised

01/98

- **1. What is the purpose of this instruction manual?** was newly added
- Instruction Manual was completely revised

Index

A		Modifications.....	90
Absolute value encoder module SSI-1.....	50	Monitor outputs	62
Access protection	66	Motors.....	19
Application range	7	Motor connector SB-056...205.....	52
		Mounting	25
B		O	
BE-7.....	8	Overview	6
C		P	
Chart with error reactions	65	Parameter.....	58
Combinations PMC-2 and SB-motors.....	82	Performance features.....	7
Commissioning	56	Product training.....	5
Communication.....	8	Programming	18
Control voltage.....	34	S	
D		Safety	20
DC-circuit.....	35	System variables.....	67
Definitions.....	82	T	
Declaration by the manufacturer	86	T1-operation.....	34
Diagnosis and operation.....	62	Technical data.....	80
Direct parameter	61	The control circuit.....	55
E		V	
Earthing	32	Variables.....	66
Electromagnetic Tolerance.....	30	Variables types.....	66
I		W	
Incremental encoder module INK-1	50	Wiring of the PMC-2 in the system.....	54
Incremental encoder simulation IKA-1	48	X	
Installation notes	24	X1 and X2 power parts	41
Interfaces.....	40	X4 Inputs and outputs – positioning level....	42
Interfaces of the additional cards.....	45	X5 Inputs and outputs – motor controller	43
L		X6 Resolver	44
LEDs.....	62	X7 COM1 and X8 COM2	44
List of all errors	63	X12 encoder.....	46
M			
Mains contactor.....	33		
Maintenance	74		