

# Operating Manual

## PacDrive™ Controller MAx-4

Article Nr.: 17130071-001

Edition: 2004-05



### **Imprint**

© All rights reserved to ELAU AG, also in case of patent right applications.

No part of this documentation and the related software and firm-ware may be reproduced, rewritten, stored on a retrieval system, transmitted or translated into any other language or computer language without the express written consent of ELAU AG.

Any possible measure was taken to ensure the that this product documentation is complete and correct. However, since hardware and software are continuously improved, ELAU makes no representations or warranties with respect to the contents of this product documentation.

### **Trademarks**

PacDrive is a registered trademark of ELAU AG.

All other trademarks mentioned are the exclusive property of their manufacturers.

ELAU AG  
Dillberg 12  
D-97828 Marktheidenfeld  
Phone: 09391/606-0  
Fax: 09391/606-300  
eMail: info@elau.de  
Internet: www.elau.de

ELAU Inc.  
4201 W. Wrightwood Ave.  
Chicago, IL 60639  
Phone: 773 342 8400  
Fax: 773 342 8404  
sales@elau.com  
www.elau.com

# Contents

<b>1</b>	<b>On this manual</b>	<b>5</b>
1.1	Introduction .....	5
1.2	Symbols, Signs and Forms of Depiction .....	6
<b>2</b>	<b>General Safety Notes</b>	<b>7</b>
2.1	Basics .....	7
2.2	Depiction of Safety Notes .....	8
2.3	Use as Directed .....	9
2.4	Selection and Qualification of Staff .....	10
2.5	Residual Risks .....	10
2.5.1	Installation and Handling .....	11
2.5.2	Protection against Touching Electrical Parts .....	12
2.5.3	"Safely Separated Low Voltages" .....	13
2.5.4	Potentially Dangerous Movements .....	14
<b>3</b>	<b>System Overview</b>	<b>15</b>
3.1	Drive Concepts of Packaging Machines .....	15
3.2	Structure of the PacDrive™ Automation System .....	17
3.3	Concept .....	18
3.4	Components .....	19
<b>4</b>	<b>Diagnosis</b>	<b>21</b>
4.1	General .....	21
4.2	Operating and display units of PacDrive Mx-4 .....	21
4.3	Connection with the PacDrive controller .....	23
4.3.1	err LED off or flashing slowly (1.7 Hz) .....	23
4.3.2	err LED flashing fast (10 Hz) .....	25
4.3.3	err LED permanently on .....	25
4.4	Example of a diagnosis message .....	25
<b>5</b>	<b>Transportation, Storage, Unpacking</b>	<b>27</b>
5.1	Transportation .....	27
5.2	Storage .....	27
5.3	Unpacking .....	27
<b>6</b>	<b>Maintenance</b>	<b>29</b>
6.1	Spare Parts, Components .....	29
6.2	Repair .....	30
6.3	Service Addresses .....	30
6.4	Exchanging units .....	31

6.5	Cleaning .....	32
6.6	EMC Rules .....	33
6.7	Commissioning .....	35
6.8	Configuration / Programming .....	36
6.9	Order number .....	37
6.9.1	PacDrive Controller MAx-4 .....	37
6.9.2	Cables .....	39
6.9.3	Connector Set .....	40
6.9.4	Accessories .....	40
<b>7</b>	<b>Technical Data</b>	<b>41</b>
7.1	In General .....	41
7.2	Interface .....	45
7.3	Electrical Connections .....	47
7.4	Dimensions .....	55
<b>8</b>	<b>Diagnosis Messages</b>	<b>57</b>
8.1	Diagnosis Classes .....	57
8.1.1	Restrictions for overwriting .....	57
8.1.2	Best Possible Stop .....	58
8.1.3	Error Stop .....	58
8.1.4	Attribute "quittable" .....	58
8.2	Reactions .....	59
8.2.1	Typical Error Profile .....	61
8.3	Diagnosis Messages .....	62
8.3.1	Diagnosis Group 1XX - Servo Amplifiers .....	62
8.3.2	Diagnosis Group 2XX Object Administration .....	81
8.3.3	Diagnosis Group 3XX - General .....	86
8.3.4	Diagnosis Group 4XX IEC Task .....	91
8.3.5	Diagnosis Group 5XX Real-Time Bus / Real-Time Process .....	93
8.3.6	Diagnosis Group 6XX Physical Master Encoder .....	99
<b>9</b>	<b>APPENDIX</b>	<b>101</b>
9.1	Contact .....	101
9.2	Further Literature .....	102
9.3	Product Training .....	104
9.4	Declaration by the manufacturer .....	105
9.5	Safety Checks .....	106
9.6	Modifications .....	107
9.7	Index .....	109
9.8	Form for Error Report .....	111

# 1 On this manual

## 1.1 Introduction

Before using ELAU components for the first time, you should familiarize yourself with this operating manual.

In particular, observe the safety notes described in chapter 2.

Only persons who meet the criteria for "Selection and Qualification of Staff" (see chapter 2.4) are allowed to work on ELAU components.

One copy of this manual has to be available for staff working on the components with access at any time.

This manual is to help you use the component safely and expertly and to use it as directed.

Observe this manual. This will help to avoid risks, reduce repair costs and down times and increase the lifetime and reliability of the products.

You also need to observe the valid rules for the prevention of accidents and for environmental protection in the country and place where the device is used.

## 1.2 Symbols, Signs and Forms of Depiction

The following symbols and signs are used in this document:



Depiction	Meaning
■	First level enumeration sign.
–	Second level enumeration sign.
▶	<b>Action symbol:</b> The text following this symbol includes an instruction for action. Execute the instruction actions in the given order, from top to bottom.
✓	<b>Result symbol:</b> The text following this symbol contains the result of an action.
<i>Italics</i>	If the describing text contains special terms (e.g. parameters) these are written in italics.
Serif font	If the manual contains program code, this is marked by Serif font.
	<b>Information symbol:</b> This symbol marks notes and useful tips for using the product.
	<b>Warning sign:</b> Safety notes can be found in the relevant places. They are marked by this symbol.
	After this symbol, information about contents of the chapter follows as guideline assistance.

Table 1-1: Symbols, signs and forms of depiction

## 2 General Safety Notes



This chapter contains general requirements for working safely. Every person using ELAU components or working on ELAU components has to read and observe these general safety notes. If activities involve a residual risk, you will find a clear note in the respective places. The note describes the risk that may occur and preventive measures to avoid that risk.

### 2.1 Basics

The ELAU components are built according to the state of technology and generally accepted safety rules. Nevertheless, their use may cause a risk to life and limb or material damage if:

- you do not use the components as directed
- work on the components is not done by experts or instructed staff
- you inexpertly alter or modify a component
- you fail to test the protective measures in place after installation, commissioning or servicing
- you do not observe the safety notes and regulations.

Only operate the components in perfect technical condition, as directed, with regard to safety and risks and observe this manual.

The flawless and safe operation of the components requires appropriate transport, storage, mounting and installation as well as careful maintenance.

In case of any circumstances that impair the safety and cause changes in the operating behavior, immediately put the component(s) to a stop and inform the service staff in charge.

In addition to this manual, observe

- the prohibiting, warning and mandatory signs on the component, the connected components and in the switching cabinet
- the relevant laws and regulations
- the operating manuals of the other components
- the universally valid local and national rules for safety and the prevention of accidents.

## 2.2 Depiction of Safety Notes

### Risk categories

The safety notes in this manual are grouped into different risk categories. The table below shows which risk and possible consequences the symbol (pictograph) and the signal words indicate.

Pictograph	Signal word	Definition
	<b>DANGER!</b>	Indicates an immediately dangerous situation that will result in death or very serious injuries if the safety rules are not observed.
	<b>WARNING!</b>	Indicates a possibly dangerous situation that can result in serious injuries or major material damage if the safety rules are not observed.
	<b>CAUTION!</b>	Indicates a possibly dangerous situation that might result in material damage if the safety rules are not observed.

Table 2-1: Risk categories



## 2.3 Use as Directed

The ELAU components are designed for installation in a machine/plant or for combination with other components to form a machine/plant. The components may only be used under the installation and operating conditions described in this documentation. You must use the accessories and ancillary parts (components, cables, etc.) mentioned in the documentation. You must not use any foreign objects or components that are not explicitly approved by ELAU.

"Use as directed" also means that you

- observe the Operating Manuals and other documentations (see appendix),
- observe the instructions for inspection and maintenance.

### *Use other than directed*

The operating conditions at the place where the device is used must be checked on the basis of the given technical data (performance information and ambient conditions) and observed.

The device must not be put into operation until it is guaranteed that the useable machine or the plant in which the motor is installed meets in its entirety EC directive 98/37/EC (machine directive).

In addition, observe the following norms, directives and regulations:

- DIN EN 60204 Safety of machines:  
Electrical equipment of machines.
- DIN EN 292 part 1 and part 2 Safety of machines:  
Basics, general design guidelines.
- DIN EN 50178 Equipment of high-voltage plants with electronic operating means.
- EMC directive 89/336/EEC

## 2.4 Selection and Qualification of Staff

This manual is aimed exclusively at technically qualified staff with detailed knowledge in the field of automation technology.

Only qualified staff can recognize the significance of safety notes and implement them accordingly.

This manual is aimed in particular at design and application engineers in the fields of mechanical and electrical engineering, at programmers, service and commissioning engineers.

### ***Working on electrical equipment***

Work on electrical equipment must only be done by qualified electricians or by instructed staff supervised by an electrician according to the electrotechnical rules.

An electrician is a person who, due to his vocational training, know-how and experience as well as knowledge of the valid regulations, is able to:

- evaluate the work he is supposed to do
- identify potential risks
- implement suitable safety measures.

## 2.5 Residual Risks

We minimized the health risk for people by means of appropriate construction and safety technology. Nevertheless, there is a residual risk, since the components work with electrical current and voltage.

## 2.5.1 Installation and Handling

---



---

### **WARNING!**

Risk of injury while handling the unit!

Risk of injury due to squeezing, cutting or hitting!

- Observe the universally valid construction and safety rules for handling and installation.
  - Use suitable installation and transport facilities and use them professionally. If necessary, use special tools.
  - Take precautions against squeezing.
  - If necessary, use suitable protective clothing (e.g. safety glasses, safety shoes, protective gloves).
  - Do not stay under pending loads.
  - Remove any leaking liquids from the floor immediately to avoid skidding.
-

### 2.5.2 Protection against Touching Electrical Parts

Touching parts carrying a voltage of 50 Volts or higher can be dangerous. When electric appliances are operated, certain parts of these appliances inevitably carry a dangerous voltage.



---

**DANGER!**

High voltage!

Life hazard!

- Observe the universally valid construction and safety rules for working on high-voltage units.
  - After installation, check the fixed connection of the earth conductor on all electric appliances according to the connection plan.
  - Operation, even for short-term measuring and test purposes, is only permitted with an earth conductor firmly connected to all electric components.
  - Before accessing electrical parts with voltages exceeding 50 Volts, disconnect the unit from mains or power supply and lock it out. After switching off, wait for at least 5 minutes before touching any components.
  - Do not touch electrical connections of the components while the unit is on.
  - Before switching on the unit, cover all voltage carrying parts to prevent accidental contact.
  - Provide for protection against indirect touching (EN 50178 / 1998 section 5.3.2).
- 



---

**DANGER!**

High leak current!

Life hazard!

- The leak current is greater than 3.5 mA. Therefore the units must have a firm connection to the power grid (according to DIN EN 50178 / 1998 - equipment of high-voltage systems).
-

### 2.5.3 "Safely Separated Low Voltages"

*PELV*  
*Protective-Extra-*  
*Low-Voltage*

Signal voltage and control voltage of the PacDrive units are <33 V. In this range the specification as PELV system according to IEC 364-4-41 includes a protective measure against directly and indirectly touching dangerous voltages by means of a "safe separation" from the primary to the secondary side in the plant/machine. ELAU urgently recommends to execute the plant/machine with safe separation.



---

#### **DANGER!**

High voltage due to wrong connection!

Life hazard or risk of serious injury!

- Only units, electric components or cables with a sufficient safe separation of the connected power supplies according to EN 50178 / 1998 (equipment of high-voltage systems with electronic operating means) may be connected to the signal voltage connections of these components.
  - Make sure that the existing safe separation is retained throughout the entire current circuit.
- 

*FELV*  
*Functional-*  
*Extra-Low-*  
*Voltage*

When using ELAU components in systems that do not include a safe separation as a means of protection against directly or indirectly touching dangerous voltages, all connections and contacts (e.g. MAX-4, Sub-D connector, serial interface) that do not comply with protection class IP2X must be permanently covered. The cover or device connection must be such that it can only be removed with the help of a tool. The protective measure must be observed on all connected devices.

### 2.5.4 Potentially Dangerous Movements

There can be different causes for potentially dangerous movements:

- mistakes in wiring or cable connection
- software errors
- faulty components
- errors in measuring value and signal encoders
- operating mistakes

The protection of people must be insured by superior means or monitoring on the plant side. You must not rely on the internal monitoring in the drive components alone. Monitoring or measures are to be provided according to a risk and error analysis by the plant builder according to the specific conditions of the plant. The valid safety rules for the plant are to be included in this process.



---

#### **DANGER!**

Potentially dangerous movements!

Life hazard, serious injury or material damage!

- No persons are allowed within the motion range of the machine. This is to be ensured by means of devices like protective fences, grids, covers or photoelectric barriers.
  - The fences and covers must be sufficiently strong to withstand the maximum possible motion energy.
  - The emergency stop switch must be located very close to the operator. Check the operation of the emergency stop before starting up the plant.
  - Secure against unintentional start by enabling the mains contactor of the drives via an emergency off circuit or by means of the function 'safe stop'.
  - Before accessing the danger zone, bring the drives to a safe stop.
  - To work on the plant, power must be turned off and locked out.
  - Avoid operating high-frequency, remote-control and radio devices in the vicinity of the plant's electronics and connecting wires. If the use of those devices is inevitable, check system and plant for possible malfunctions before first operation. In some cases a special EMT check may be necessary.
-

## **3 System Overview**

### **3.1 Drive Concepts of Packaging Machines**

Modern machine concepts in the packaging industry are characterized by the need for high dynamism, flexibility, modularity and efficiency. Packaging machines were traditionally equipped with a mechanical vertical shaft, which drove the secondary motions in the machine usually with mechanical components with complicated motion functions. Designing such a machine flexibly for different products is a highly complex task. Even minor changes in the packaging process, particularly in case of a product change, require major modifications and standstill time.

Packaging machines with electronic vertical shafts, by contrast, permit full flexibility. Electronic servo drive systems replace cam and coupling gears, and a virtual electronic vertical shaft ensures that the motion axes are synchronous. Any pulse and angle synchronous movements are determined by a central control.

Unplanned machine states, such as stop or emergency off situations or initialization movements can be realized synchronously. Dynamic changes of the goods to be packed or the packaging material in the plant, (like slippage of the products to be packed or expansion of the packaging material) can be registered by sensors while the machine is running and eliminated by modifying the corresponding drive movements. This development substantially changes and highly simplifies the classical mechanical machine concept. The structure of the packaging machine can be broken down into modules that are easy to apply and can be standardized.

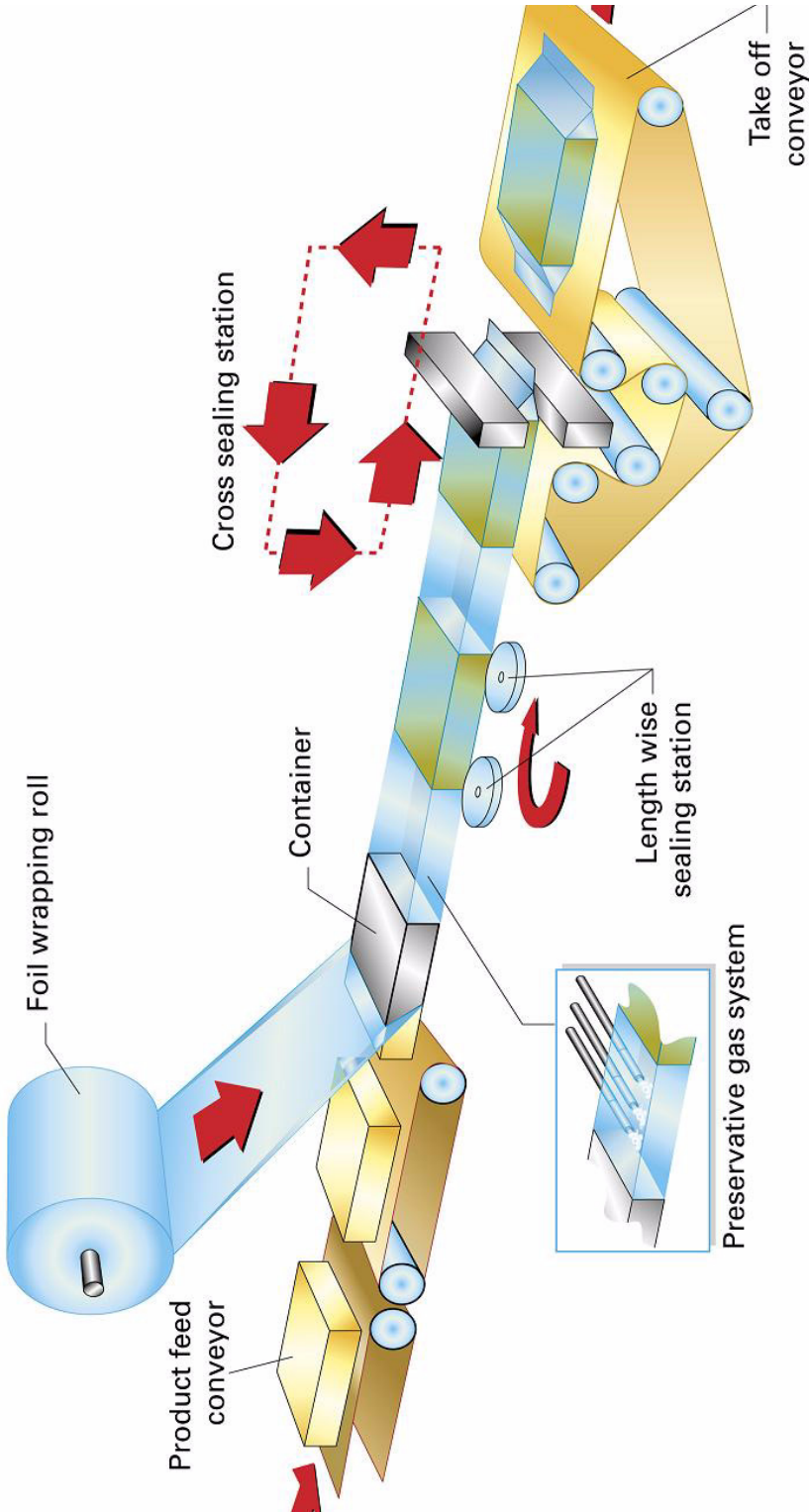

Fig. 3-1: Sketch of a packaging machine



## 3.2 Structure of the PacDrive™ Automation System

The PacDrive™ automation system offers a technically and economically optimal solution for electronic packaging machines. PacDrive™ consists of an efficient PC-based control, the PacDrive Controller MAX-4 and the digital MC-4 MotorControllers, which include the mains connection unit, the end-stage power and the servo regulator of the individual axes (Fig. 3-2).

The PacDrive Controller MAX-4 is the intelligent head of the system, and is based on an industrial PC. The PacDrive Controller MAX-4 synchronizes and coordinates the motion functions of the packaging machine. Using an IEC 1131-3 soft PLC, it ventures into applications previously reserved for standard PLCs. The individual PLC or positioning tasks can be broken down into several parallel tasks, which are implemented with the EPAS-4 programming environment according to the IEC 1131-3 standard. Up to 40 servo axes can be connected to a PacDrive Controller MAX-4 and supplied with positioning data.

The circular digital SERCOS real-time bus realizes the safe data exchange with the MC-4 MotorControllers. Due to the use of optical fiber technology, the data bus is insensitive to electromagnetic disturbance and cyclically supplies the decentralized MC-4 MotorControllers with new set values at a data rate of 4MBaud. All internal states of the axes can be checked via the real-time bus and processed in the PacDrive Controller MAX-4.

In addition to digital and analog inputs and outputs, the PacDrive Controller MAX-4 has two serial interfaces and one Ethernet interface. A variety of process visualization and control systems can be connected to the PacDrive™ M via the integrated OPC interface. Further peripheral components can be connected via field bus interface modules. The PacDrive Controller MAX-4 can act as a field bus master or slave.

The international field bus standards CANopen, PROFIBUS-DP and DeviceNet are supported. The built-in interfaces enable remote diagnosis via telephone modem or Internet. Via TCP/IP, PCs can communicate with the PacDrive Controller MAX-4 and diagnose the state of the control directly.

### 3.3 Concept

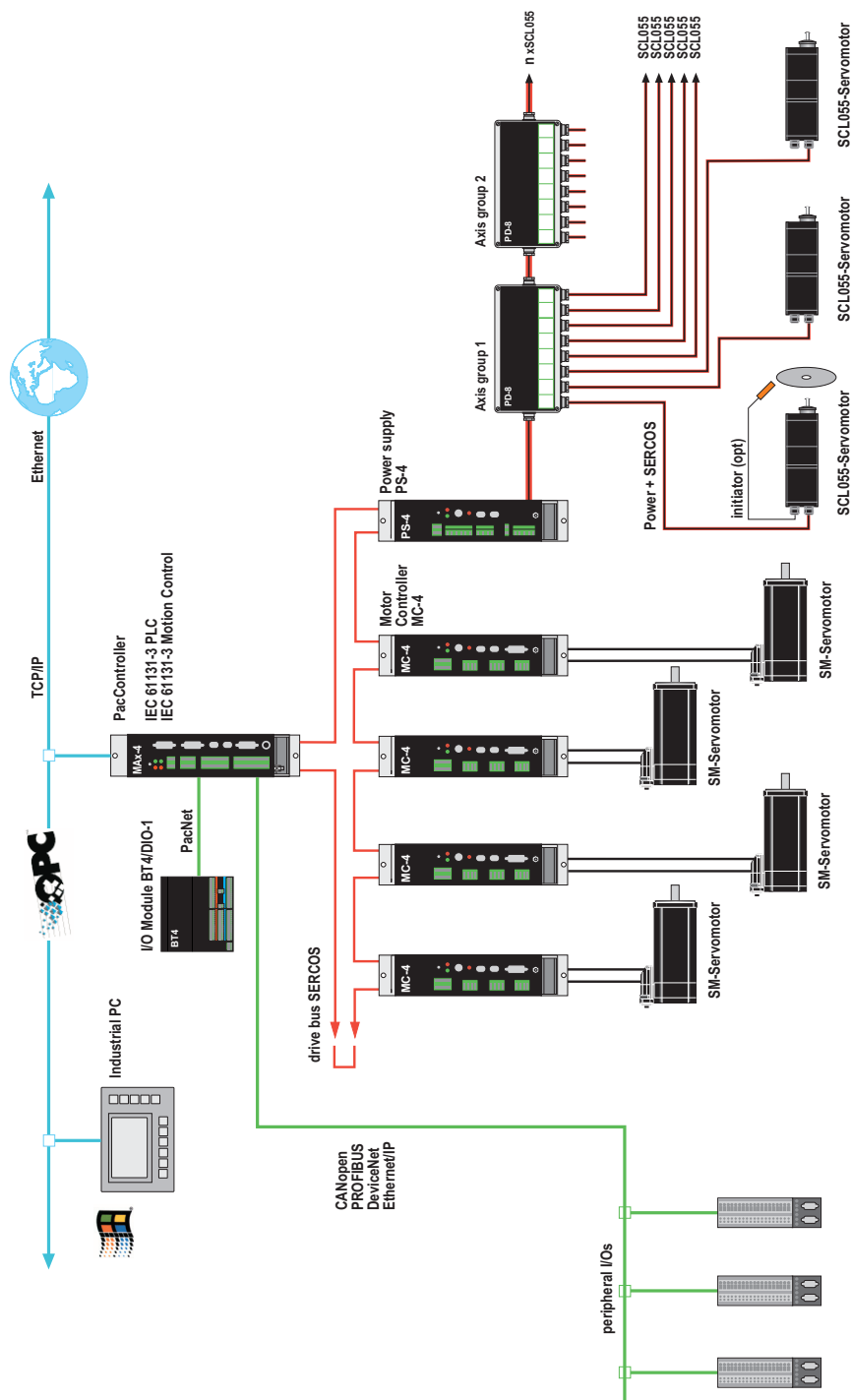

Fig. 3-2: System overview of the PacDrive™ automation concept

Alternatively, the PacDrive Controller can be connected to a conventional PLC via a field bus.

## 3.4 Components

### Automation Toolkit EPAS-4

EPAS-4 has extensive and proven functions and tools. A key advantage of EPAS-4 is that all components are integrated and intuitive.

For you as a user, this means:

Quick familiarization, eas handling, all tools integrated.

**Libraries** ELAU maintains extensive libraries geared to the packaging industry, helping you obtain cost effective and speedy answers to any concern. They will also help you to improve the quality of your user programs.

#### The highlights of EPAS-4 Automation Toolkit

- Runs under Windows (recommended WinXP)
- Programming language IEC 61131-3
- SCOPE tool (oscilloscope functions)
- Diagnosing tool
- very good debugging features
- serial or TCP/IP connection to the PacDrive Controller MAx-4

### PacDrive Controller Family

The PacDrive Controller, a Pentium based controller hardware with VxWorks real-time operating system, realizes the PLC and motion functions.

A PacDrive Controller synchronizes, coordinates and generates the positioning functions for a maximum of 44 drives of a food and packaging machine.

For HMI tasks, various standard HMIs are used. Whether low-cost clear text or IPC - no problem for the flexible PacDrive Controller.

The PacDrive Controller P600 is equipped with a complete PC. Due to this PC based technologie in addition the P600 can be also used for HMI applications.

### MC-4 Servo drive

**Leading-edge technology** The digital MC-4 Servo drive is characterised by its compact and autonomous structure suitable for wall mounting as well as its leading-edge technology. The innovative MC-4 has the mains supply unit, end stage and software regulator for one axis integrated in a compact casing. As it communicates with the PacDrive Controller only via fibre optical cable, it is also suitable for a decentralized structure. It requires no user program, comes with single- and multi-turn processing features as standard and configures itself with the help of the electronic name plate in the SM motor.

#### The highlights of the MC-4 MotorController

- World-wide voltage range
- Integrated mains supply unit
- Max. power 34.5 / 69 kVA
- Automatic motor recognition
- Minimum size
- Safety input Inverter Enable
- 250 % overload
- Integrated SERCOS interface
- few types

### SM-Motor

**Highly dynamic servo motors** Machines with fast cycle rates require highly dynamic AC servo motors. The SM motor series offers you as a user an optimum motor concept for your food and packaging machines. The dynamic brushless servo motors are furnished with high-resolution encoders (single-turn or multi-turn) and electronic name plate. Smooth surface and compact size meet the requirements of the target market.

#### The highlights of the SM motors

- Low mass moment of inertia
- 4-fold overload
- Reliable high-voltage technology
- Leading-edge magnetic technology
- High-resolution single- or multi-turn encoder
- Electronic name plate
- Plug in junction box
- IP 65 protection

## 4 Diagnosis

### 4.1 General

The PacDrive™ system supports the user with its extensive diagnosis system.

The diagnosis messages can be read with the Automation Toolkit EPAS-4. The PacDrive™ system also contains a powerful message logger, which records additional diagnosis information.

Normally the diagnosis messages are displayed on an operating unit on the machine.

In case of an error, read this diagnosis message and contact your machine producer.



#### NOTE

For further details on the diagnosis, please consult the online help of the Automation Toolkit EPAS-4.

### 4.2 Operating and display units of PacDrive MAx-4

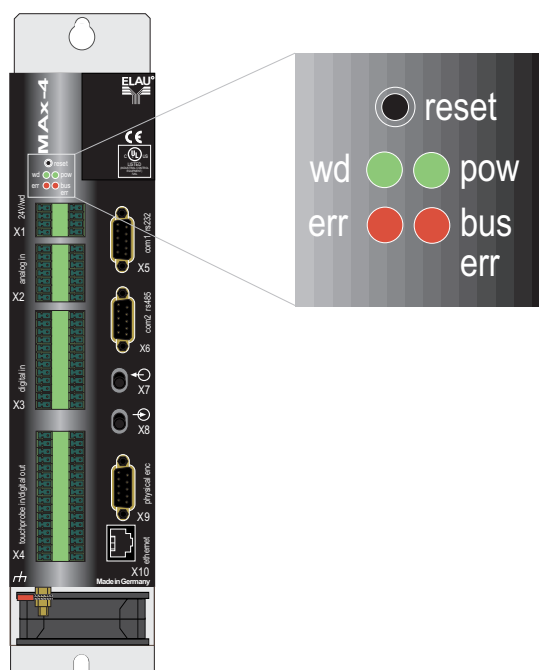

Fig. 4-1: Diagnosis LEDs

#### reset



Button to reset the PacDrive controller. Only the PacDrive controller is rebooted when you press the "reset" button. Other MC-4 servo amplifiers that may be connected have their own "reset" buttons.

### wd (watchdog)



Watchdog is a hardware module for monitoring the controller.

OFF	normal operation
ON	fatal error, reset necessary



#### NOTE

A "fatal error" is a serious hardware problem or an unexpected serious software problem.

When a "fatal error" occurs,

- the CPU is stopped
- the optional modules are reset
- the outputs are reset
- the wd (watchdog) relay output is opened.

### pow (control voltage indicator)



the power LED (pow) indicates the state of the control voltage.

OFF	control voltage (24 V) missing or too low
ON	normal operation; control voltage in normal range

### err (error indicator)



The error LED (err) indicates errors. The table below lists possible states of the error LED with corresponding error descriptions.

OFF	normal operation
Flashing slowly (1.7 Hz)	error of classes 1, 2, 3, 4 or 5 active (see PacDrive™ programming manual, reference part)
Flashing fast (10 Hz)	MAX-4 boot completed, last boot failed see diagnosis message 209 "last boot failed"
ON	a serious error occurred during the actual boot



#### NOTE

The err LED is switched on after starting the BIOS. After loading operating system, user configuration, user parameters and IEC program and successfully starting the IEC program, the err LED is switched off again. The booting procedure is thus completed.

### bus err (SERCOS real-time bus error indicator)



OFF	normal operation
ON	bus error (fiber-optic connection problem, e.g. send power too low or too high, broken cable,...)

**NOTE**

The state of the bus err LED is undefined while booting.  
The sender capacity (fiber-optic connection intensity) is set in the control configuration of the PacController MAX-4.

**PacDrive controller minimal boot**

If an application error results in a serious boot error, the user can run a minimal boot. The PacController MAX-4 automatically boots in minimal configuration if, during the booting process:

- the control voltage drops
- a MAX-4 reset is triggered
- a serious error occurs. (Memory cannot be called up)

When booting in minimal configuration, the user data (control configuration and IEC program) are not loaded.

**How to run a minimal boot**

- ▶ Boot the PacDrive controller by pressing the "**reset**" button.
- ✓ The PacDrive controller starts, the "**err**" error indicator is on.
- ▶ Press the "**reset**" button while the "**err**" indicator is on.
- ✓ After the boot, the PacDrive controller is flashing fast (10 Hz) to indicate the minimal boot.

## 4.3 Connection with the PacDrive controller

There are two ways to connect the (service) PC (EPAS-4) with the PacDrive controller:

- serial cable
- Ethernet connection (10/100 Base-T)

If a connection between EPAS-4 and PacDrive controller is not possible, this can be due to one or several of the reasons described below.

### 4.3.1 err LED off or flashing slowly (1.7 Hz)

**TCP/IP connection not possible**

- ▶ Check IP\_Address in EPAS-4 at ONLINE / Communication parameters ... .
  - Is the channel (collective term for connection parameters) set correctly?
  - Is the TCP/IP address set correctly?
  - Is the port set to "5000"?
  - Is the Motorola byteorder set to "no"?

- ▶ Check the TCP/IP settings in the control configuration of the project.
  - Is the parameter IP\_SubNetMask filled in correctly?
  - Is the parameters IP\_Address entered correctly and is it identical with the entry in ONLINE / Communication parameters in EPAS-4?
  - Is the parameters IP\_GatewayAddress entered correctly?
- ▶ Establish a serial connection with the PacDrive controller.
  - Enter the settings for a serial connection in ONLINE / Communication parameters (Port = "5000"(depending on the computer); Baudrate = "38400"; Parity = "No"; Stop bits = "1"; Motorola byteorder = "No").
  - Establish the serial connection.
- ▶ Check the settings in the control configuration of the PacDrive controller.
  - Is the IP\_SubNetMask entered correctly?
  - Is the parameter IP\_Address correct and is it identical with the entry in ONLINE / Communication parameters in EPAS-4?
  - Is the address IP\_Gateway entered correctly?
- ▶ If you found a mistake, adjust the parameters.
  - Take over the parameters with ONLINE / Take over parameters
  - Activate the parameters with ONLINE / Reset control

### **No serial connection via COM1 of the MAx-4**

- ▶ Check the serial cable. The "jumpers" must be there. You can find the connector allocation in EPAS-4 online help and in the "Operating Manual EPAS-4"
- ▶ Check the settings for the serial interface of the PC in ONLINE / Communication parameters (Port = "depending on the computer"; Baudrate = "38400"; Parity = "No"; Stop bits = "1"; Motorola byteorder = "No").
- ▶ You probably configured a modem in the control configuration in PacDriveM / General / Com1User "Modem / 1" In this case, a modem is expected instead of the Com1 serial interface of the MAx-4.
- ▶ Execute a minimal boot to change the COM1 serial interface to EPAS-4.

See also "PacDrive controller minimal boot" on page 23.



**The file transfer service could not be started!**

- ▶ Check if the flash disk of the PacDrive controller MAx-4 is full.
  - Log on without file transfer with EPAS-4.
  - Check the free memory with the help of the parameter *Diskfree* in Control configuration / MAx-4 / Memory & Disks.
  - With the help of the FTP client, you can delete files on the flash disk.

It may be possible/necessary to exchange the flash disk in the PacDrive controller against a flash disk with a larger memory.

**4.3.2 err LED flashing fast (10 Hz)**

See also "209 last boot failed" on page 83..

**4.3.3 err LED permanently on**

See also "Operating and display units of PacDrive MAx-4" on page 21.

**4.4 Example of a diagnosis message**

The diagnosis message 2121 "Bleeder temperature too high" is shown.

Meaning of the diagnosis message:

- Class 2 error
- Diagnosis code 121

The meaning of the diagnosis code is further explained in the online help of the Automation Toolkits EPAS-4.

**121 Bleeder temperature too high**

- The bleeder is overloaded.

<b>Cause</b>	The drive is dimensioned wrongly.
<b>Solution</b>	Check drive dimensioning
<b>Cause</b>	Hardware error: bleeder or control is defective.
<b>Solution</b>	Contact our customer service.



## **5** **Transportation, Storage, Unpacking**

### **5.1** **Transportation**

- ▶ Avoid shocks.
- ▶ Immediately check units for transport damage and inform your transport company, if necessary.

### **5.2** **Storage**

- ▶ Store units in a clean, dry place.

**Storage conditions:**

- air temperature between - 25 °C and + 70 °C.
- temperature fluctuations max. 30 K per hour.

### **5.3** **Unpacking**

- ▶ Check whether the delivery is complete.
- ▶ Check all units for transport damage.

### Type plate

The type plate contains all necessary information:

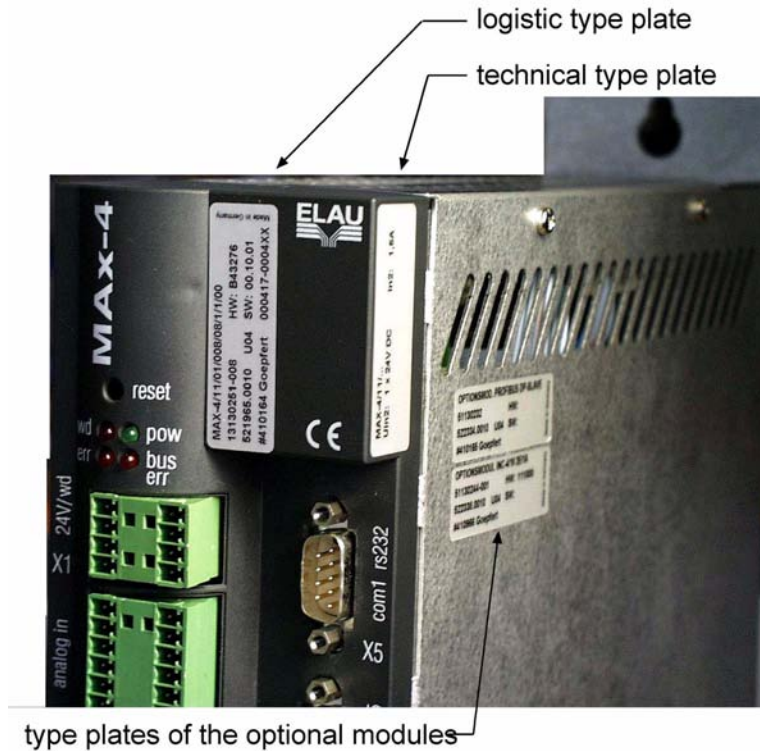

Fig. 5-1: type plates at the MAX-4

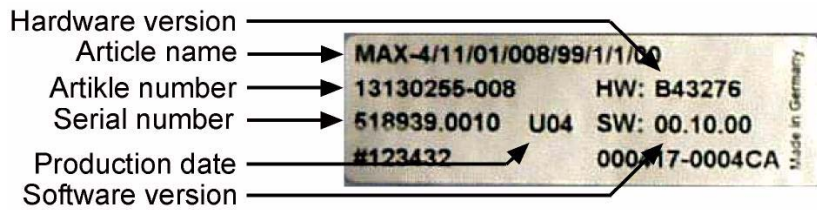

Fig. 5-2: logistic type plate of a MAX-4

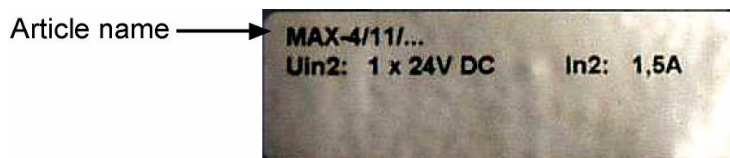

Fig. 5-3: technical type plate of a MAX-4

## 6 Maintenance

Recognizing and clearing an error quickly helps to keep the related production loss down to a minimum.

The diagnosis messages of the PacDrive™ system, which can be checked using the Automation Toolkit EPAS-4, make it possible to look for errors deliberately and effectively.

In case of an error, defective components can be exchanged with no problem. This ensures that the problem can be solved quickly and operation can be resumed soon. This work must be done by qualified service staff only.

When returning a defective unit to the ELAU customer service, please complete the attached error report form.

### 6.1 Spare Parts, Components

#### Stock keeping of spare parts:

Keeping a stock of the essential components is a key prerequisite for the permanent functionality of the equipment.



#### CAUTION!

Device compatibility!

The plant no longer works correctly after components have been exchanged!

- Only units with identical hardware configuration and identical software may be exchanged.

#### When ordering spare parts, please give the following data:

Article name: e.g. MAX-4/10/01/008/99/1/1/00

Article number: e.g. 13130255-008

Hardware code: e.g. HW: 630062

Hardware code: e.g. SW: 00.05.00

You can find this information on the type plate of the equipment (see Fig. 5-1) or in the configuration of the PacDrive™ system.

## 6.2 Repair

By all means complete the attached error report form when returning defective components.  
You can also make a photocopy of the error report form and use it as a fax message.



---

### NOTE

To avoid transport damage and ensure a that the repair can be executed smoothly, by all means observe the procedure described in chapter „Exchanging units" on page 31.

---

## 6.3 Service Addresses

### For ordering spare parts

ELAU AG  
Postfach 1255  
D-97821 Marktheidenfeld  
Phone: +49 (0) 93 91 / 606 - 0  
Fax: +49 (0) 93 91 / 606 - 300

### For repair

Please send the components to be repaired or checked, along with the error report, to this address:

ELAU AG  
Abt. Kundendienst                      street address:  
Postfach 1255                              Dillberg 12  
D-97821 Marktheidenfeld      D-97828 Marktheidenfeld  
Phone: +49 (0) 93 91 / 606 - 142  
Fax: +49 (0) 93 91 / 606 - 340

### Service team

Should you need to talk to a member of our service team or require on-site service, please contact:

ELAU AG  
Abt. Applikation  
Postfach 1255  
D-97821 Marktheidenfeld  
Phone: +49 (0) 93 91 / 606 - 0  
Fax: +49 (0) 93 91 / 606 - 300

## 6.4 Exchanging units

In addition to the notes below, please observe the information of the machine producer when exchanging the PacDrive controller.

### Exchanging PacDrive Controller MAx-4:

- ▶ Take preparatory measures.



#### **DANGER!**

High voltage!

Life hazard!

- Before working on electrical units, disconnect from mains supply and lock out.
- Make sure that the drives are safely standing, because potentially fatal voltages can occur on motor cables of servo motors in generator operation.
- Do not disconnect connector plugs while they are carrying voltage.



#### **CAUTION!**

Electro static discharge!

Components may be damaged!

- Only touch the boards on the edges.  
Do not touch any connections or components.
- Before touching the boards, discharge any possible static charge. For this purpose, touch a grounded metal surface, e.g. the casing.
- Do not place the boards on a metal surface.
- Move the boards as little as possible to avoid the creation of electro static charge due to clothing, carpets or furniture.

- ▶ Open main switch.
- ▶ Lock out main switch.
- ▶ Disconnect all cables from the PacDrive Controller MAx-4.
- ▶ Open screws on the top and bottom of the casing.
- ▶ Remove PacDrive controller.



---

### **CAUTION!**

Electro static discharge!

Components may be damaged!

- Return electronic components in original or equivalent packaging only. In any case, the components must be wrapped in an ESD packaging/foil; otherwise warranty claims will be lost.
- 

- ▶ Install new PacDrive controller and tighten the screws.
- ▶ Connect the new PacDrive controller according to the connection plan of the machine.
  - The exchange of a PacController MAx-4 requires a reload of the user project with a PC on which EPAS-4 is installed.
- ▶ Place the PacDrive controller in need of repair in suitable transport packaging.
- ▶ Restart the plant.

## **6.5 Cleaning**

---

With suitable installation, the units are to a large extent maintenance-free. To remove dust and foreign objects brought in by the cooling air flow, disconnect the units from the power supply, remove them and use dry compressed air (max. 1 bar) to blow away the pollution.



## 6.6 EMC Rules

To control and regulate motors, the mains voltage is stored in the DC-circuit of the MotorController by means of rectification. This stored energy is fed to the motor by deliberately activating and deactivating six semiconductor switches. The steep rise and fall of the voltage puts high demands on the insulation strength of the motor winding. Another essential aspect to be considered is **Electro Magnetic Compatibility (EMC)** with other system components. The flank steepness of the clocked voltage generates harmonic oscillation of great intensity, up into the high-frequency range.

### Therefore observe the following EMC rules:

- ▶ Choose the grounding option with the lowest possible ohm rate (e.g. unpainted mounting board of switching cabinet) for installation.
- ▶ Contact the largest possible surface (skin effect). If necessary, remove existing paint to achieve large-surface contact.
- ▶ From the **Central Earthing Point**, lay the grounding wires to the respective connections in a star structure. Earthing loops are not allowed and can cause unnecessary distortions.
- ▶ Use shielded encoder cables only.
- ▶ Only large-surface shield transitions are allowed.
- ▶ Shields must not be contacted via PIN contacts of connector plugs.
- ▶ By all means observe the switching proposals.
- ▶ Cut motor cables to minimum length.
- ▶ Do not lay any cable loops inside the switching cabinet.



---

### CAUTION!

Electromagnetic fields!

Disturbances or failure of the system possible!

- The rules described below must be observed for installation, in order to rule out the consequences of excessive disturbance effects as far as possible.
- 
- In correlation with electronic controls, no inductive loads whatsoever must be switched without suitable interference elimination.
  - For DC operation, suitable interference elimination can be achieved by arranging recovery diodes. For AC operation, commercially available erasing elements matching the connector type can be used.
  - Only the interference elimination element mounted immediately at the point of inductivity serves this purpose. Otherwise, the switching pulse may even emit increased interference via the interference elimination elements. It is much easier to avoid sources of interference in the first place, than to eliminate the effects of existing interference.
  - In no case must the contacts switching unerased inductive loads be arranged in the same room as the MC-4 servo amplifier. The same goes for cables carrying unerased, switched inductivity and cables running parallel to them. The control must be separated from such "disturbers" by a Faraday cage (own section in the switching cabinet).



---

### CAUTION!

Electromagnetic fields!

Disturbances or failure of the system possible!

- Depending on the combination of servo amplifier / motor and the cable length, you need to use a mains choke, possibly system filters or motor filters.  
See also Project manual for PacDrive™ system.
-

## 6.7 Commissioning

We urgently recommend that you use ELAU staff for commissioning.

You should do so not only for warranty reasons. At the same time

- the equipment is checked,
- the optimum configuration is determined,
- and the operating staff are instructed.

### Commissioning procedure:

- Unpacking and checking**
- ▶ Remove packaging
  - ▶ Make sure the units are not damaged. Only undamaged units should be put into operation.
  - ▶ Check if the consignment is complete.
  - ▶ Check if the optional slots are occupied correctly.
  - ▶ Check the data with the help of the type plate.

See also chapter "Exchanging units".

- Installation**
- ▶ Observe requirements for the place in which the equipment may be used.
  - ▶ Observe the requirements for protection and EMC rules.
  - ▶ Mount devices.

See also chapter "Maintenance".

- Electrical installation**
- ▶ Connect the units, starting with the ground conductor.
  - ▶ Make sure the clamps are tight and the required cable cross sections are correct,
  - ▶ Make sure the shield is executed correctly, rule out short-circuit and interruptions.

See also chapter "Maintenance".

- Connect ion of 24 V control voltage**
- ▶ Check mains and control voltage.
  - ▶ Connect external 24 V control voltage.
  - ✓ Initialize the units; the LEDs should show the following state:
    - MAX-4: pow: ON, err: ON, buserr: ON, wd: OFF
    - MC-4: pow: ON, err: flashing, buserr: ON

See also chapter "Diagnosis"

- Check of safety functions**
- ▶ Check thermo contact of the motor or PTC. (see operating manuals for the connected components)
  - ▶ Check the function of the brake (if any).
  - ▶ Check EMERGENCY OFF chain and EMERGENCY OFF switch.

- Connection of mains voltage**
- ▶ Activate EMERGENCY OFF switch.
  - ▶ Connect mains voltage.
  - ▶ Check if the state indicator works correctly.
  - ▶ Deactivate EMERGENCY OFF switch.
- Axis movement**
- ▶ When you move the axis for the first time, use a reliable small user program in order to check:
    - the correct turning direction of the axis
    - the correct setting of the limit switches
    - the brake path in both directions.
- Configuration and program transmission**
- ▶ Transmit project to the PacDrive Controller MAx-4 with the Automation Toolkit EPAS-4



### **DANGER!**

Potentially dangerous movements!

Life hazard, risk of serious injury or material damage!

- Make sure that there are no persons in the danger zone.
  - Remove all tools, loose parts and other auxiliaries that do not form part of the axis/machine/plant from the motion range. (Make sure the plant is ready for operation)
  - ELAU recommends not to couple the working machine until the function test has been completed successfully!
- 

- Function test**
- ▶ Check units and cabling again.
  - ▶ If it has not been done already, connect mains voltage.
  - ▶ Run function check by means of a check list for axis/machine/plant functions.
- Further commissioning of the plant**
- ▶ Continue to commission the plant according to the operating manual of the machine producer.

## 6.8 Configuration / Programming

---

The PacDrive™ system is adjusted to its task with the Automation Toolkit EPAS-4.

In EPAS-4 the system is commissioned and programmed according to IEC 61131-3.

**CAUTION!**

Complex functionality of the PacDrive™ system and the machine!  
Possible material damage!

- Program changes may only be done by trained staff with detailed system knowledge. Therefore changes may only be done by your machine supplier or ELAU staff.  
ELAU AG accepts no liability for damage due to arbitrary program modifications.

## 6.9 Order number

### 6.9.1 PacDrive Controller MAx-4

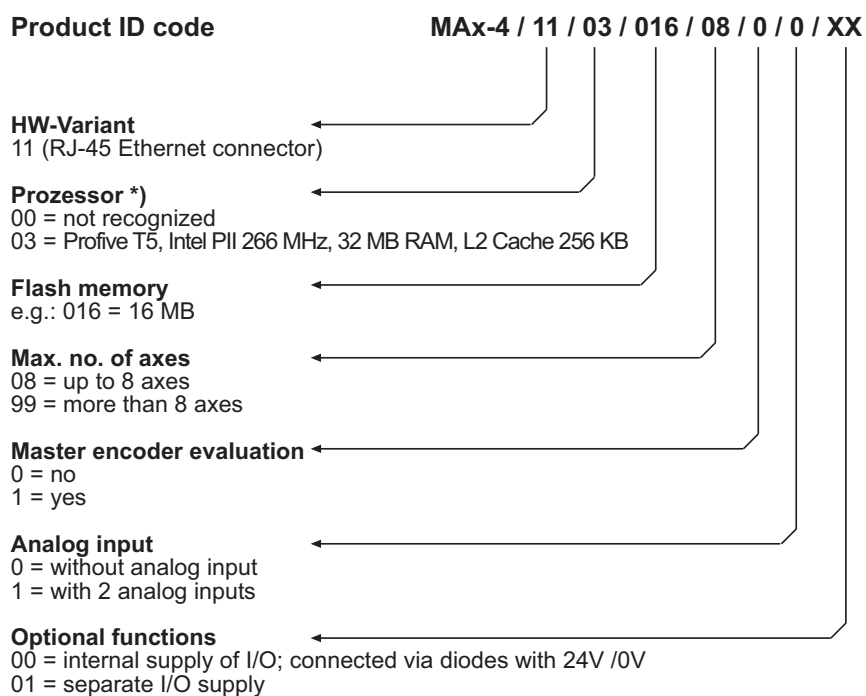

\*) **Note** Previous version of the processor:  
01 = Profive P5, AMD K6 266 MHz, 16 MB RAM, L2 Cache 256 KB  
02 = Profive P5, AMD K6 266 MHz, 32 MB RAM, L2 Cache 256 KB

Fig. 6-1: Type key for PacDrive Controller MAx-4

Order number	Article name	Explanation
13 13 02 51 - 002	MAx-4 / 11 / 02 / 016 / 08 / 0 / 0 / 00	MAx-4
13 13 02 51 - 012	MAx-4 / 11 / 02 / 016 / 08 / 0 / 0 / 01	MAx-4
13 13 02 51 - 004	MAx-4 / 11 / 02 / 016 / 08 / 1 / 0 / 00	MAx-4
13 13 02 51 - 014	MAx-4 / 11 / 02 / 016 / 08 / 1 / 0 / 01	MAx-4
13 13 02 51 - 006	MAx-4 / 11 / 02 / 016 / 08 / 0 / 1 / 00	MAx-4
13 13 02 51 - 016	MAx-4 / 11 / 02 / 016 / 08 / 0 / 1 / 01	MAx-4
13 13 02 51 - 008	MAx-4 / 11 / 02 / 016 / 08 / 1 / 1 / 00	MAx-4
13 13 02 51 - 018	MAx-4 / 11 / 02 / 016 / 08 / 1 / 1 / 01	MAx-4
13 13 02 55 - 002	MAx-4 / 11 / 02 / 016 / 99 / 0 / 0 / 00	MAx-4
13 13 02 55 - 012	MAx-4 / 11 / 02 / 016 / 99 / 0 / 0 / 01	MAx-4
13 13 02 55 - 004	MAx-4 / 11 / 02 / 016 / 99 / 1 / 0 / 00	MAx-4
13 13 02 55 - 014	MAx-4 / 11 / 02 / 016 / 99 / 1 / 0 / 01	MAx-4
13 13 02 55 - 006	MAx-4 / 11 / 02 / 016 / 99 / 0 / 1 / 00	MAx-4
13 13 02 55 - 016	MAx-4 / 11 / 02 / 016 / 99 / 0 / 1 / 01	MAx-4
13 13 02 55 - 008	MAx-4 / 11 / 02 / 016 / 99 / 1 / 1 / 00	MAx-4
13 13 02 55 - 018	MAx-4 / 11 / 02 / 016 / 99 / 1 / 1 / 01	MAx-4

Table 6-1: Order numbers and variants of MAx-4

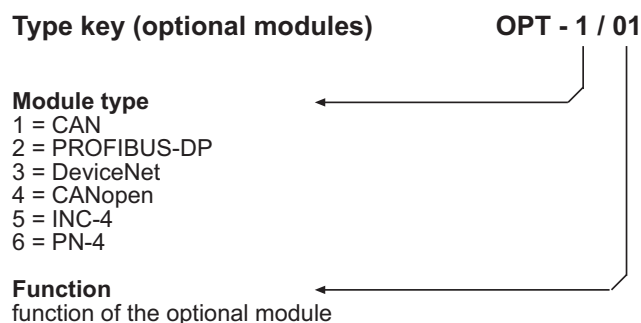

Fig. 6-2: Type key for PacController MAx-4 optional modules

Designation	Module type	Function
OPT-1/01	CANL2	CAN layer 2
OPT-2/01	PROFIBUS-DP	PROFIBUS DP slave
OPT-2/02	PROFIBUS-DP	PROFIBUS DP master
OPT-3/01	DeviceNet	DeviceNet slave
OPT-4/01	CANopen	CANopen master / slave
OPT-5/01	INC-4	incremental encoder module 2 inputs 1 output
OPT-5/02	INC-4	incremental encoder module 5 inputs 1 output
OPT-5/03	2 INC-4	incremental encoder module 10 inputs 2 outputs
OPT-6/01	PN-4	PacNet module

Table 6-2: Possible variants for optional modules

**NOTE**

The designation of the optional modules is shown in the control configuration under *MAx-4.Versions.Opt1Type*, *MAx-4.Versions.Opt2Type* and *MAx-4.Versions.Opt3Type*.

Order number	Article name	Explanation
51 13 02 31	OM/MAx-4/CAN layer 2	in MAx-4
51 13 02 32	OM/MAx-4/PROFIBUS DP slave	in MAx-4
51 13 02 37	OM/MAx-4/PROFIBUS DP master	in MAx-4
51 13 02 38	OM/MAx-4/CAN-OPEN M/S	in MAx-4
51 13 02 40	OM/MAx-4/DEVICE-NET slave	in MAx-4
51 13 02 44 - 001	OM/MAx-4/INC-4/10 2 In/1 Out	in MAx-4
51 13 02 44 - 002	OM/MAx-4/INC-4/10 5 In/1 Out)	in MAx-4
51 13 02 44 - 003	OM/MAx-4/INC-4/10 10 In/2 Out	in MAx-4
51 13 02 44 - 011	OM/MAx-4/INC-4/10 2 I/1 O 24V	in MAx-4
51 13 02 44 - 012	OM/MAx-4/INC-4/10 5 I/1 O 24V	in MAx-4
51 13 02 44 - 013	OM/MAx-4/INC-4/10 10 I/2 O 24V	in MAx-4
51 13 02 58	OM/MAx-4/PN-4/10	in MAx-4
-	Ethernet/IP slave	in preparation

Table 6-3: Order numbers for optional modules for MAx-4

## 6.9.2 Cables

### Encoder cables

Order number	Article name	Explanations
15 15 42 11-XXX	E-FB-065 MAx-SIN-ME UL	on MAx-4 X9
15 15 42 12-XXX	E-FB-066 MAx-SIN-ME	on MAx-4 X9
15 15 20 08	E-FB-028	incremental encoder on MAx-4 / INC-4

Table 6-4: Order numbers for encoder cables

### Interface cables

Order number	Article name	Explanations
15 15 43 01	E-SS-054 (PC)	on MAx-4 X5 (COM 1)
15 15 43 03-XXX	E-SS-056 REAL-TIME-BUS	on MC-4 X5 on MAx-4 X7
15 15 43 04-030	E-SS-057 (PC)	on MC-4 X7

Table 6-5: Order numbers for interface cables

### 6.9.3 Connector Set

Order number	Article name	Explanations
15 15 44 03	Connector set MAX-4 FRONT	Complete connector set for front side of MAX-4

Table 6-6: Order number for the connector set

### 6.9.4 Accessories

Order number	Article name	Explanations
13 13 02 57	bus terminal BT-4/DIO1	for PacNet
17 19 50 04	ME/SINCOS SRS50 STAND ALONE	master encoder
17 19 50 05	ME/SINCOS SRM50 KVAF MULTITURN	master encoder
17 19 10 19 - 003	incremental master encoder DG 60 LWSR 5,000 incr / rev	master encoder for INC-4
17 19 10 19 - 006	incremental master encoder DG 60 LWSR 10,000 incr / rev	master encoder for INC-4
ME 08600	warning label: high voltage	105 x 52mm

Table 6-7: Order numbers for accessories



## 7 Technical Data

### 7.1 In General

	Parameter	Value
<b>Product configuration</b>	Product ID code - MAx-4 up to 8 axes - MAx-4 up to 99 axes	MAx-4 / 11 / 02 / 016 / 08 / x / x / xx MAx-4 / 11 / 02 / 016 / 99 / x / x / xx
	Order code - MAx-4 up to 8 axes - MAx-4 up to 99 axes	13 13 02 51 - xxx 13 13 02 55 - xxx
<b>Processor</b>	CPU	Intel Pentium II 266 MHz
	RAM	32 MB
	L2 Cache	512 kB
	NVRAM	32 kB
	CompactFlash™ Disk	16 MB (internal)
	Real time clock (RTC)	yes, optional hardware required
	Watchdog	yes
	Diagnostics	status LEDs
<b>Operating System</b>	Real-time operating system	VxWorks
<b>Programming languages</b>	Programming languages IEC 61131-3	Continuous Function Chart (CFC) Function Block Diagram (FBD) Instruction List (IL) Ladder Diagram (LD) Sequential Function Chart (SFC) Structured Text (ST)
<b>Interfaces</b>	Communication interfaces COM1 COM2	RS232 (X5) RS485 (X6)
	Network interface	Ethernet (10 Base-T) (X10)
	Fieldbus interfaces	PROFIBUS DP Master (12 MBaud) <sup>1)</sup> PROFIBUS DP Slave (12 MBaud) <sup>1)</sup> CAN (2.0B) <sup>1)</sup> CANopen <sup>1)</sup> DeviceNet Slave <sup>1)</sup> Ethernet/IP Slave <sup>1)</sup>  <sup>1)</sup> optional hardware module required

	<b>Parameter</b>	<b>Value</b>
	Motion bus interface	SERCOS interface (4 MBaud) <b>(X7, X8)</b>
	PacNet interface	1 PacNet interface <sup>1)</sup> <sup>1)</sup> optional hardware module required
	Encoder interface	1 SinCos encoders up to 10 incremental encoder <sup>1)</sup> <sup>1)</sup> optional hardware module required
	HMI interface	Operator panels: RS485 using Modbus or PROFIBUS DP  HMI software tools: OPC server (Windows NT/2000/XP or Windows CE)
	Remote Diagnostics interface	Web server or modem
	Communication protocols	http, ftp, SMTP (email)
	Integrated trace recorder (software oscilloscope)	8 channels 1 msec resolution
	Integrated logger for diagnostic messages	27 kB
<b>Performance</b>	Motion performance	11 Servo axes @ 1 ms SERCOS cycle 23 Servo axes @ 2 ms SERCOS cycle 45 Servo axes @ 4 ms SERCOS cycle  max. 255 cam profiles running in parallel
	PLC performance	15 µsec for 1000 Bit instructions  unlimited number of PLC tasks PLC task types: continuous, periodic or event-triggered  Cycle time Fast Task: 250 µsec  Nominal I/O response time: 500 µsec (reading input, processing data, setting output)
<b>PLS</b>	Programmable limit switches (PLS)	max. 256  Type: dynamic  Outputs: memory or digital outputs  Inputs: external master encoder, virtual master encoder, or axes position  Scan time: 250 µsec

Parameter	Value
<b>I/Os</b> Integrated digital inputs (X3)	number: 20  range $U_{IN}$ 0 state: DC 0 ... 6 V range $U_{IN}$ 1 state: DC 20 ... 33 V input current: $I_{IN} = 5$ mA on $U_{IN} = 24$ V pole safe: yes input filter: 3.5 ... 5.5 ms
Integrated analog inputs (X2)	number: 2  range $U_{IN}$ : -7 ... 10 V (impedance 100 k) or range $I_{IN}$ : 0 ... 20 mA (impedance 500 R)
Integrated interrupt inputs (X4)	number: 4  range $U_{IN}$ 0 state: DC 0 ... 6 V range $U_{IN}$ 1 state: DC 20 ... 33 V input current: $I_{IN} = 5$ mA on $U_{IN} = 24$ V pole safe: yes input filter: 0.07 ... 0.17 ms
Integrated touchprobe inputs (X4)	number: 16  range $U_{IN}$ 0 state: DC 0 ... 6 V range $U_{IN}$ 1 state: DC 20 ... 33 V input current: $I_{IN} = 5$ mA on $U_{IN} = 24$ V pole safe: yes input filter TP0 to TP15: 100 $\mu$ s resolution time TP0 to TP3: 15.6 $\mu$ s @ 1, 2, 4 ms cycle time resolution time TP4 to TP15: 15.6 $\mu$ s @ 1 ms cycle time 32.25 $\mu$ s @ 2ms cycle time 62.5 $\mu$ s @ 4ms cycle time
Integrated digital outputs (X4)	number: 16  output voltage: $(+UL-3$ V) < $U_{OUT}$ < +UL rated current: $I_e = 100$ mA per output switch current: $I_{e,max} < 0.5$ A for 1 s leakage current 0 signal: < 0.4 mA transmission time: 0.04 ... 0.31 ms short-circuit-proof: yes relay outputs: DC 20 ... 30 V / 2 A
Integrated analog outputs	none
Additional digital and analog I/Os	via fieldbus  max. 3.584 Bytes digital/analog inputs and max. 3.584 Bytes digital/analog outputs  max. number of stations: 126 (PROFIBUS)

	Parameter	Value
<b>Power supply</b>	Additional fast digital I/Os	via PacNet max. 128 inputs and 128 outputs
	Additional touchprobe inputs	via PacNet max. 16 touchprobe inputs
	Power supply	DC 24 V (-15% / +25%) / max. 3.15 A
	Power consumption	max. 60 W
	Uninterruptable power supply UPS	external
<b>Environment</b>	Product size	width: 69 mm height: 270 mm depth: 240 mm
	Box size	width: 100 mm height: 400 mm depth: 300 mm
	Product weight Boxed weight	2.4 kg 3.0 kg
	Ambient conditions - protection class - ambient temp.  - insulation - rel. humidity	IP20 +5 ... +55 °C (in operation) -25 ... +70 °C (for storage and transport) degree of pollution 2 ..., no dewing allowed 5% ... 85% climatic category 3K3 EN 60 721
<b>Approval</b>	Approvals	CE, UL , cUL

Table 7-1: Technical data for the PacDrive Controller Mx-4

## 7.2 Interface

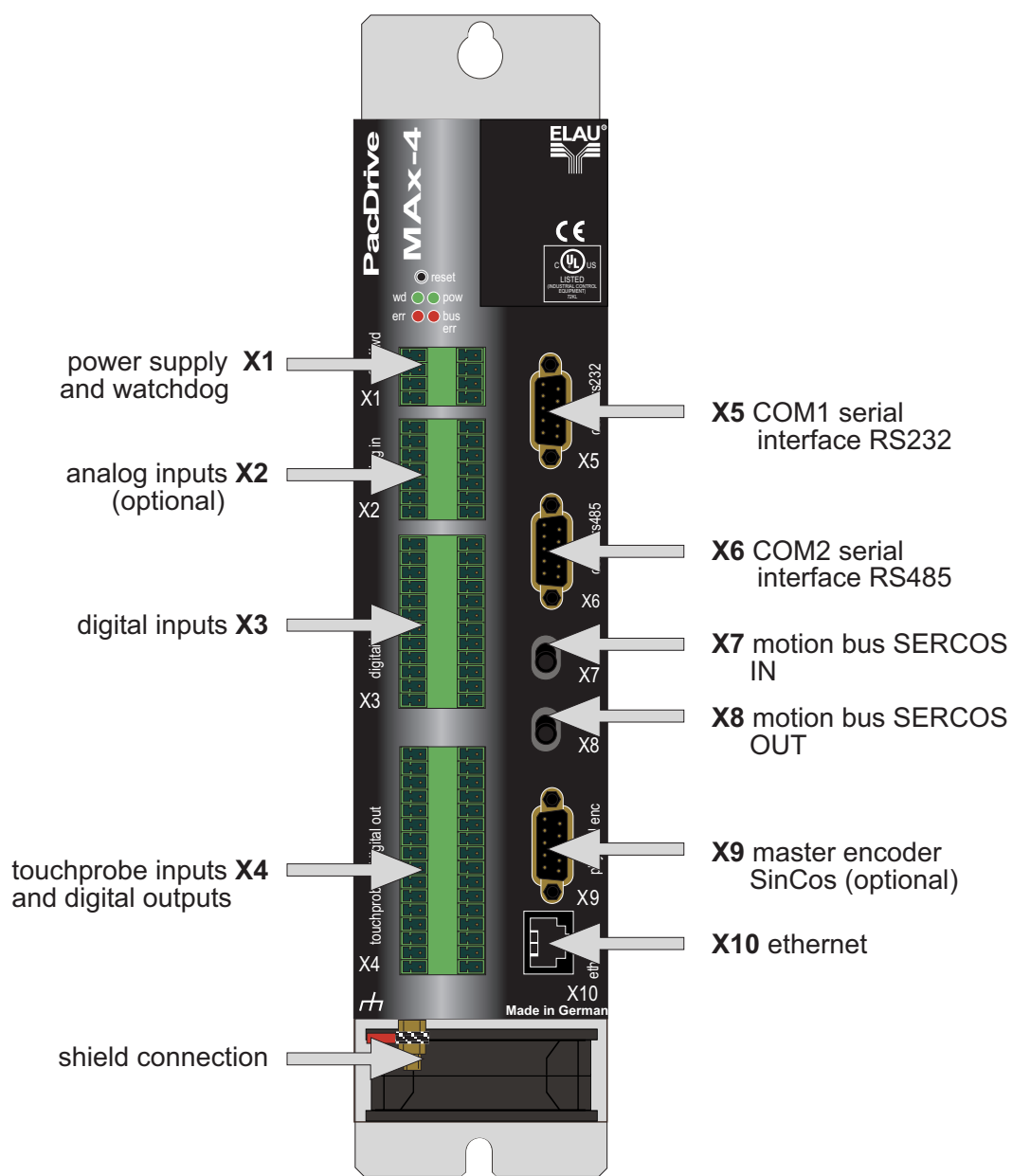

PDM\_Anschlussübersicht\_MAX-4\_us9912.FH8

Table 7-1: Overview of the PacDrive Controller MAX-4



## 7.3 Electrical Connections

### X1 - control voltage and watchdog

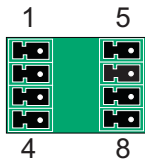

Pin	Designation	Meaning	Range	Max. cross section
1	DC +24 V	supply voltage	- 15% / +25%	1.5 mm <sup>2</sup>
2	0 V	supply voltage		1.5 mm <sup>2</sup>
3	+UL	for digital outputs	DC +24V -15% / +25%	1.5 mm <sup>2</sup>
4	L0	for digital inputs / outputs		1.5 mm <sup>2</sup>
5	DC +24 V	supply voltage	-15% / +25%	1.5 mm <sup>2</sup>
6	DC 0 V	supply voltage		1.5 mm <sup>2</sup>
7	WD	watchdog relay		1.5 mm <sup>2</sup>
8	WD	watchdog relay		1.5 mm <sup>2</sup>

Table 7-1: Electrical connections of MAX-4 / X1

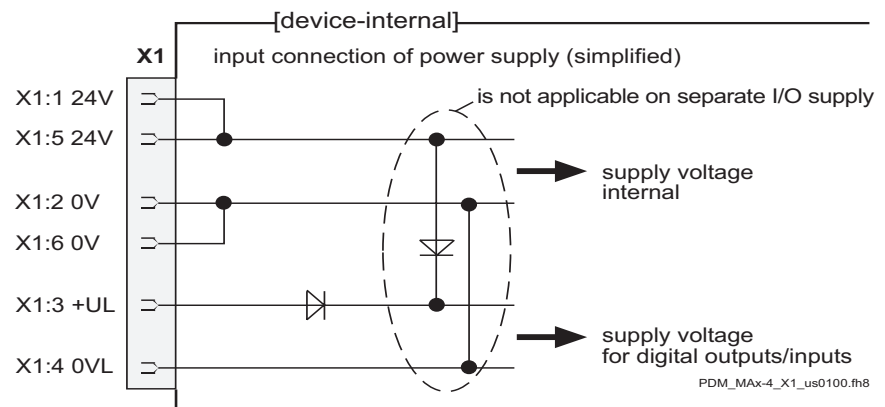

Fig. 7-1: Electrical connections of MAX-4 / X1 input connection



### CAUTION!

Disconnection of control voltage!

Risk of data loss or damage to flash disk!

- Use UPS, and the control voltage of the PacDrive Controller may only be switched off if all files are closed. See also Programming Manual -Reference- Function *SysShutdown()*.

**X2 - analog inputs**

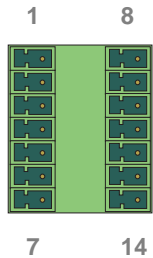

Pin	Designation	Meaning	Range	Max. cross section
1	a1+	analog input 1+	differential input	1.5 mm <sup>2</sup>
2 *)	a1-	analog input 1-	-7 V ... +10 V	1.5 mm <sup>2</sup>
3	AGND	analog GND		1.5 mm <sup>2</sup>
4	PE	shield		1.5 mm <sup>2</sup>
5	12 V	output voltage	Ri = 1k	1.5 mm <sup>2</sup>
6	j1	bridge power input		1.5 mm <sup>2</sup>
7	j1	bridge power input		1.5 mm <sup>2</sup>
8	a2+	analog input 2+	differential input	1.5 mm <sup>2</sup>
9 *)	a2-	analog input 2-	-7 V ... +10 V	1.5 mm <sup>2</sup>
10	AGND	analog GND		1.5 mm <sup>2</sup>
11	PE	shield		1.5 mm <sup>2</sup>
12	12 V	output voltage	Ri = 1k	1.5 mm <sup>2</sup>
13	j2	bridge power input		1.5 mm <sup>2</sup>
14	j2	bridge power input		1.5 mm <sup>2</sup>

\*) Voltages and currents outside the specified ranges lead to wrong measuring values (AnalogIn.Value).  
 If the voltage to be measured relates to AGND, only positive voltages and currents from 0 V to +10 V or 0 mA to 20 mA can be processed.  
 This is equivalent to an AnalogIn.Value of 2048 to 4096.

Table 7-2: Electrical connections of MAX-4 / X2

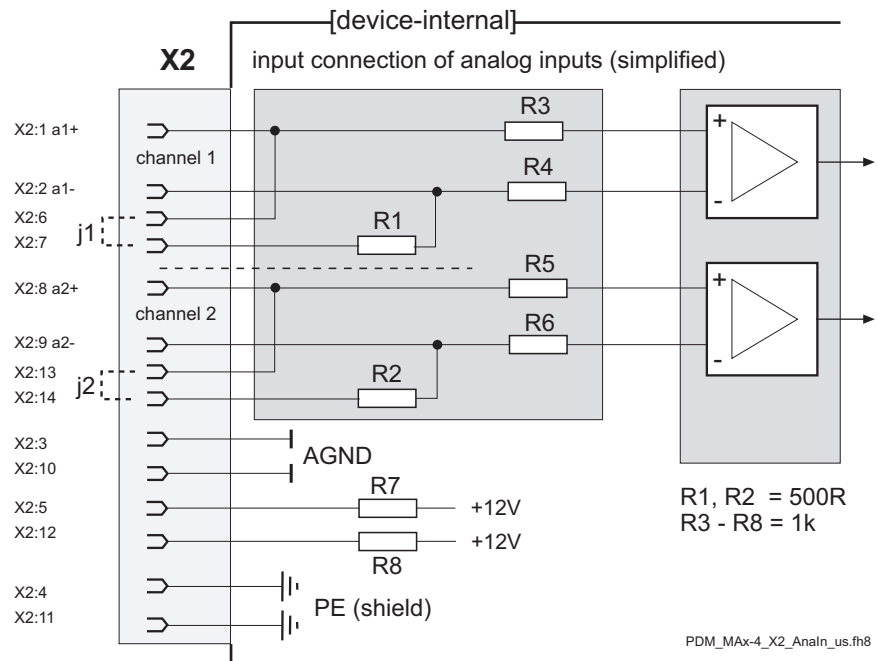
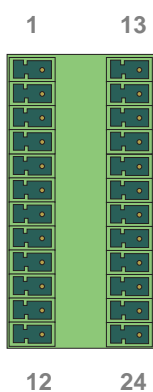

Fig. 7-2: Electrical connections of MAX-4 / X2 input connection



## X3 - digital inputs



Pin	Designation	Meaning	Range	Max. cross section
1	0.0	standard input 0	DC 20 ... 30 V	1.5 mm <sup>2</sup>
2	0.1	standard input 1	DC 20 ... 30 V	1.5 mm <sup>2</sup>
3	0.2	standard input 2	DC 20 ... 30 V	1.5 mm <sup>2</sup>
4	0.3	standard input 3	DC 20 ... 30 V	1.5 mm <sup>2</sup>
5	0.4	standard input 4	DC 20 ... 30 V	1.5 mm <sup>2</sup>
6	0.5	standard input 5	DC 20 ... 30 V	1.5 mm <sup>2</sup>
7	0.6	standard input 6	DC 20 ... 30 V	1.5 mm <sup>2</sup>
8	0.7	standard input 7	DC 20 ... 30 V	1.5 mm <sup>2</sup>
9	0.8	standard input 8	DC 20 ... 30 V	1.5 mm <sup>2</sup>
10	0.9	standard input 9	DC 20 ... 30 V	1.5 mm <sup>2</sup>
11	0.10	standard input 10	DC 20 ... 30 V	1.5 mm <sup>2</sup>
12	0.11	standard input 11	DC 20 ... 30 V	1.5 mm <sup>2</sup>
13	0.12	standard input 12	DC 20 ... 30 V	1.5 mm <sup>2</sup>
14	0.13	standard input 13	DC 20 ... 30 V	1.5 mm <sup>2</sup>
15	0.14	standard input 14	DC 20 ... 30 V	1.5 mm <sup>2</sup>
16	0.15	standard input 15	DC 20 ... 30 V	1.5 mm <sup>2</sup>
17	0.16	standard input 16	DC 20 ... 30 V	1.5 mm <sup>2</sup>
18	0.17	standard input 17	DC 20 ... 30 V	1.5 mm <sup>2</sup>
19	0.18	standard input 18	DC 20 ... 30 V	1.5 mm <sup>2</sup>
20	0.19	standard input 19	DC 20 ... 30 V	1.5 mm <sup>2</sup>
21	1.0	interrupt input 0	DC 20 ... 30 V	1.5 mm <sup>2</sup>
22	1.1	interrupt input 1	DC 20 ... 30 V	1.5 mm <sup>2</sup>
23	1.2	interrupt input 2	DC 20 ... 30 V	1.5 mm <sup>2</sup>
24	1.3	interrupt input 3	DC 20 ... 30 V	1.5 mm <sup>2</sup>

Table 7-3: Electrical connections of MAX-4 / X3

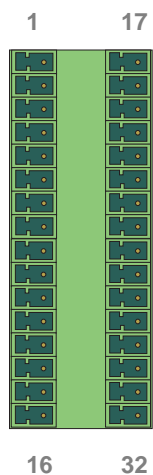
**X4 - touchprobe inputs and digital outputs**

Pin	Designation	Meaning	Range	Max. cross section
1	2.0	touchprobe input 0	DC 20 ... 30 V	1.5 mm <sup>2</sup>
2	2.1	touchprobe input 1	DC 20 ... 30 V	1.5 mm <sup>2</sup>
3	2.2	touchprobe input 2	DC 20 ... 30 V	1.5 mm <sup>2</sup>
4	2.3	touchprobe input 3	DC 20 ... 30 V	1.5 mm <sup>2</sup>
5	2.4	touchprobe input 4	DC 20 ... 30 V	1.5 mm <sup>2</sup>
6	2.5	touchprobe input 5	DC 20 ... 30 V	1.5 mm <sup>2</sup>
7	2.6	touchprobe input 6	DC 20 ... 30 V	1.5 mm <sup>2</sup>
8	2.7	touchprobe input 7	DC 20 ... 30 V	1.5 mm <sup>2</sup>
9	2.8	touchprobe input 8	DC 20 ... 30 V	1.5 mm <sup>2</sup>
10	2.9	touchprobe input 9	DC 20 ... 30 V	1.5 mm <sup>2</sup>
11	2.10	touchprobe input 10	DC 20 ... 30 V	1.5 mm <sup>2</sup>
12	2.11	touchprobe input 11	DC 20 ... 30 V	1.5 mm <sup>2</sup>
13	2.12	touchprobe input 12	DC 20 ... 30 V	1.5 mm <sup>2</sup>
14	2.13	touchprobe input 13	DC 20 ... 30 V	1.5 mm <sup>2</sup>
15	2.14	touchprobe input 14	DC 20 ... 30 V	1.5 mm <sup>2</sup>
16	2.15	touchprobe input 15	DC 20 ... 30 V	1.5 mm <sup>2</sup>
17	0.0	standard output 0	DC20..30 V/0.1A	1.5 mm <sup>2</sup>
18	0.1	standard output 1	DC20..30 V/0.1A	1.5 mm <sup>2</sup>
19	0.2	standard output 2	DC20..30 V/0.1A	1.5 mm <sup>2</sup>
:	:	:	:	:
27	0.10	standard output 10	DC20..30 V/0.1A	1.5 mm <sup>2</sup>
28	0.11	standard output 11	DC20..30 V/0.1A	1.5 mm <sup>2</sup>
29	0.12	standard output 12	DC20..30 V/0.1A	1.5 mm <sup>2</sup>
30	0.13	standard output 13	DC20..30 V/0.1A	1.5 mm <sup>2</sup>
31	0.14	standard output 14	DC20..30 V/0.1A	1.5 mm <sup>2</sup>
32	0.15	standard output 15	DC20..30 V/0.1A	1.5 mm <sup>2</sup>

Table 7-4: Electrical connections of MAx-4 / X4

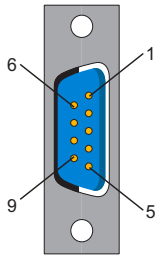
**X5 - Com 1 (RS232)**

Pin	Designation	Meaning	Range	Max. cross section
1	DCD	Data Carrier Detect		0.25 mm <sup>2</sup>
2	RxD	Receive Data		0.25 mm <sup>2</sup>
3	TxD	Transmit Data		0.25 mm <sup>2</sup>
4	DTR	Data Terminal Ready		0.25 mm <sup>2</sup>
5	GND	Signal Ground		0.25 mm <sup>2</sup>
6	DSR	Data Set Ready Clear To Send		0.25 mm <sup>2</sup>
7	RTS	Request To Send		0.25 mm <sup>2</sup>
8	CTS	Clear To Send		0.25 mm <sup>2</sup>
9	RI	Ring Indicator		0.25 mm <sup>2</sup>

Table 7-5: Electrical connections of Mx-4 / X5

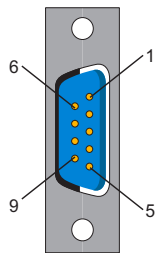
**X6 - Com 2 (RS485)**

Pin	Designation	Meaning	Range	Max. cross section
1	+5 VM	supply voltage		0.25 mm <sup>2</sup>
2	TxD-	RS485 Transmit -		0.25 mm <sup>2</sup>
3	TxD+	RS485 Transmit+		0.25 mm <sup>2</sup>
4	RxD+	RS485 Receive +		0.25 mm <sup>2</sup>
5	RxD-	RS485 Receive -		0.25 mm <sup>2</sup>
6	GNDR	GND receive RS485		0.25 mm <sup>2</sup>
7	-	reserved		0.25 mm <sup>2</sup>
8	GNDM	supply voltage		0.25 mm <sup>2</sup>
9	GNDR	GND receive RS485		0.25 mm <sup>2</sup>

Table 7-6: Electrical connections of Mx-4 / X6

**X9 - master encoder (SinCos, optional)**

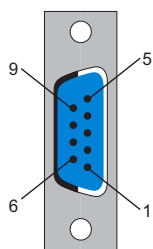

Pin	Designation	Meaning	Range	Max. cross section
1	REFSIN	sinus reference signal		0.25 mm <sup>2</sup>
2	SIN	sinus trace		0.25 mm <sup>2</sup>
3	REFCOS	cosine reference signal		0.25 mm <sup>2</sup>
4	COS	cosine trace		0.25 mm <sup>2</sup>
5	+12 V	supply voltage		0.25 mm <sup>2</sup>
6	RS485-	parameter channel -		0.25 mm <sup>2</sup>
7	RS485+	parameter channel +		0.25 mm <sup>2</sup>
8	SC_SEL	encoder connected (bridge to GND)		0.25 mm <sup>2</sup>
9	GND	supply voltage		0.25 mm <sup>2</sup>

Table 7-7: Electrical connections of MAx-4 / X9



**CAUTION!**

Disconnection of SinCos encoder plug while unit is powered on! SinCos encoder may be damaged!

- Disconnect and connect the SinCos encoder plug only in voltage-free state (disconnect MC-4 MotorController from 24 V power supply!).

**X10 - Ethernet**

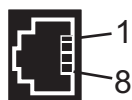

Pin	Designation	Meaning	Range	Max. cross section
1	Tx+	OutputTransmitData+		
2	Tx-	OutputTransmitData-		
3	Rx+	InputReceiveData +		
4	-	reserved		
5	-	reserved		
6	Rx-	InputReceiveData -		
7	-	reserved		
8	-	reserved		

Table 7-8: Electrical connections of MAx-4 / X9

**NOTE**

Depending on the application, different cables are required for the connection to the PacDrive MAX-4 via the RJ-45 connector plug.

- Connection PacDrive Controller <-> „corporate network“ mit RJ-45  
-> straight twisted-pair cable
- Connection PacDrive Controller <-> Hub  
-> straight twisted-pair cable
- Connection PacDrive Controller <-> PC  
-> crossover twisted-pair cable

In doubt, please contact your network administrator.

**Connector plugs of MAX-4 optional modules**

Fig. 7-3: Connector plug on the front side and the bottom side of the MAX-4 „special casing“

Priority	optional module	standard connector plug (alternative connector)	more alternative connector plug with special case
1 (highest)	PacNet PN-4	X15	-
2	PROFIBUS DP master	X11	-
3	PROFIBUS DP slave	X11 (X12)	X12
4	CANopen master	X11 (X12)	X12
5	CANopen slave	X11 (X12)	X12
6	CAN layer 2	X11 (X12)	X12
7	DeviceNet	X13	-
8	INC-4 (OPT-5 / 01) - 1st input (Incln_0) - 2nd input (Incln_1) - output - 24 V supply (encoder)	X14 X13 X12 X11 (X15)	X16 X17 X21 X28
9	INC-4 (OPT-5 / 02) - 1st input (Incln_0) - 2nd input (Incln_1) - 3rd input (Incln_2) - 4th input (Incln_3) - 5th input (Incln_4) - output - 5V/24V supply (enc.)		X16 X17 X18 X19 X20 X21 X28
10	INC-4 (OPT-5 / 03) - 1st input (Incln_0) - 2nd input (Incln_1) - 3rd input (Incln_2) - 4th input (Incln_3) - 5th input (Incln_4) - 1st output - 6th input (Incln_5) - 7th input (Incln_6) - 8th input (Incln_7) - 9th input (Incln_8) - 10th input (Incln_9) - 2nd output - 5V/24V supply (enc.)		X16 X17 X18 X19 X20 X21 X22 X23 X24 X25 X26 X27 X28

Fig. 7-4: Priority of the optional modules when allocating connector plugs

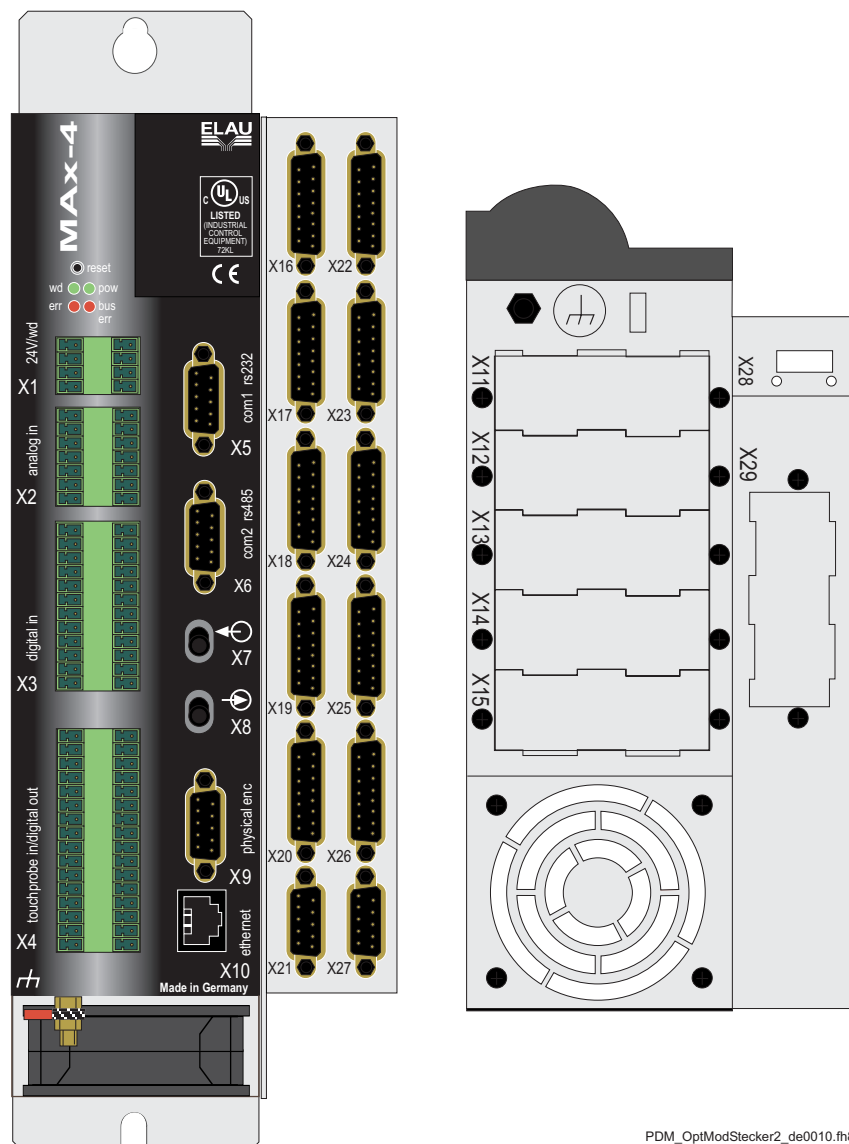

#### NOTE

Only one CAN or CANopen module can be installed per PacController MAX-4. A maximum of 3 optional modules can be installed in the PacDrive Controller MAX-4.

When using the extension cover, the external 5 V / 24 V power supply for the encoder is always on X28.

#### Note:

When using INC-4 with only one additional module, the extension cover is not needed. The internal encoder supply can be used.

#### Exception:

When using INC-4 with only one additional DeviceNet module, the extension cover is needed! However, you can still use the internal encoder supply.

## 7.4 Dimensions

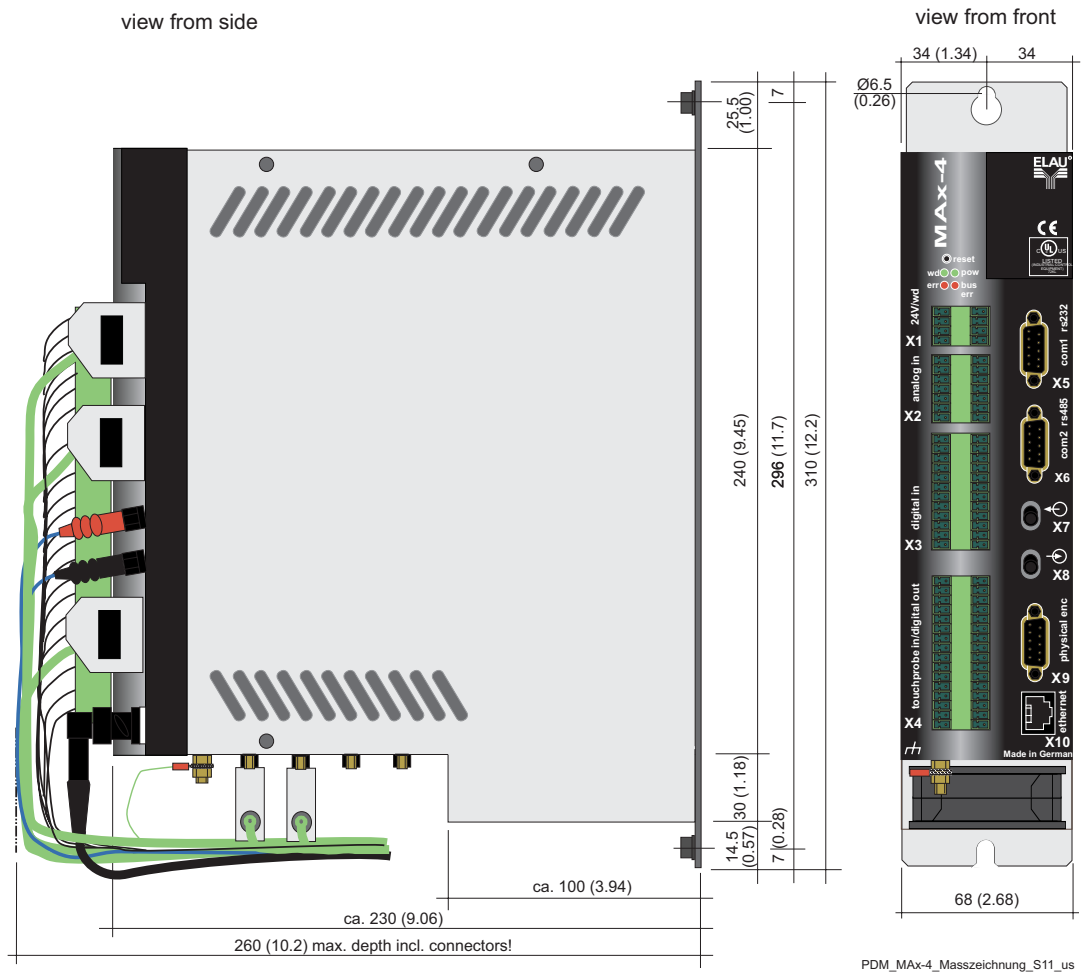

PDM\_MAX-4\_Masszeichnung\_S11\_us

Fig. 7-1: Dimensions of the PacDrive MAX-4 / "standard casing"

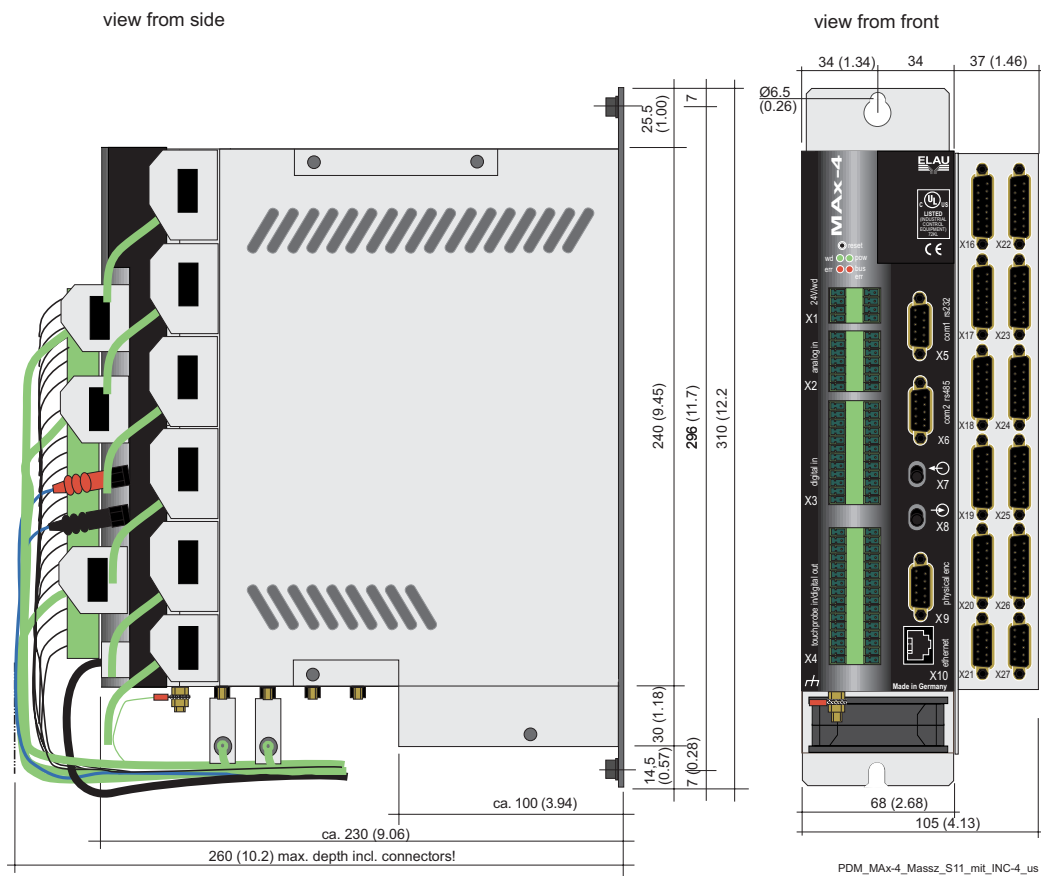

Fig. 7-2: Dimensions of the PacDrive MAX-4 / "special casing" for additional connector plugs



## 8 Diagnosis Messages

### 8.1 Diagnosis Classes



This chapter contains only the most important diagnosis messages. A complete list of diagnosis messages is available in EPAS-4 online help, PacDrive, Diagnosis, Diagnosis Messages.

There are several diagnosis classes of different priorities, depending on their consequences for the whole system. At PowerOn, a certain diagnosis class is assigned to every diagnosis code. The assignment can be partly overwritten by the user program (function DiagConfigSet()).

Diagnosis class	Designation of diagnosis classes	Priority
1	fatal error	high
2	error with complete switch-off	
3	error with individual switch-off	
4	error with complete stop	
5	error with individual stop (is the error is triggered by one axis)	
6	warning	
7	message	low
8	logger entry	none

Table 8-1: Diagnosis classes and reactions / priority

#### 8.1.1 Restrictions for overwriting

Only classes 1, 2 and 3 may be assigned to certain internal diagnosis codes (servo amplifier with reaction A, B and C).



#### NOTE

The reaction (A ... E) connected with diagnosis messages of the type "servo amplifier MC-4" cannot be changed.

Error class 8 is used by the system. It must not be changed.

Each diagnosis class has certain system reactions assigned permanently:

Class	1	2	3	4	5	6	7	8	9
Record in message log file	X	X	X	X	X	X	X	X	-
Best possible stop of all drives	X	X	-	-	-	-	-	-	-
Best possible stop of the causing drive	-	-	X	-	-	-	-	-	-
Error stop of all drives	-	-	-	X	-	-	-	-	-
Error stop of the causing drive	-	-	-	-	X	-	-	-	-
Inform IEC program (function DiagMsgRead() )	X	X	X	X	X	X	X	-	-
Address ERROR LED	X	X	X	X	X	-	-	-	-
Configurable	X	X	X	X	X	X	X	-	-
Update PacDrive controller diagnosis parameter	X	X	X	X	X	X	-	-	-
Update MC-4 diagnosis parameter	X	X	X	X	X	X	X	-	-

Table 8-2: Diagnosis classes and system reactions

### 8.1.2 Best Possible Stop

If *Enable* (see Control configuration / Servo amplifier / State / *ControllerEnable* and *HW\_Enable*) is lifted, the drive is brought to a best-possible stop with *DrivePeakC*. *DrivePeakC* can be influenced with *LimCurrent*.

### 8.1.3 Error Stop

If *ControllerStop* (see Control configuration / MotorController MC-4 / State / *ControllerStop*) is active, the drive is stopped with *StopDec*.

### 8.1.4 Attribute "quittable"

Every diagnosis message has an attribute "quittable", which determines whether the diagnosis message can be quitted or not. The user can change the attribute by means of the IEC program.



#### NOTE

In case of errors that cannot be quitted, the PacDrive controller must be reset. This is done by the reset button on the front side of the PacDrive controller. For group 1 errors (servo amplifier) with reaction A, the servo amplifier must be reset as well. This is done by the reset button on the front side of the servo amplifier.

## 8.2 Reactions

Errors of the diagnosis group "servo amplifier" have an additional reaction.

Reaction	Diagnosis example	Meaning
A	119 short-circuit or short to ground in the end stage	motor becomes torque-free immediately; brake engages immediately
B	112 communication error in real-time bus	best possible self-stop: motor brakes with max. deceleration, brake engages at $n < n_{min}$ (10 revolutions/min) or after 400 ms; drive becomes torque-free after 500 ms
C	124 overload switch-off	motor brakes with max. deceleration, but remains in control, brake does not engage
D	125 I2t motor warning	warning message to PacDrive controller; controlled, synchronous stop by program possible; if there is no reaction, a class 1 error may occur
E	133 torque-dependent current reduction	message

Table 8-3: Reaction of MC-4 servo amplifier diagnosis messages

See also

- Time Diagrams Servo Amplifier

### bus err LED (SERCOS)

The "bus err" LED on PacDrive components makes it possible to detect interruptions of the fiber-optic cable or

the incorrect setting of the intensity of a sender in the SERCOS loop quickly and easily.

The LED turns off if telegrams with faultless telegrams are received.

After the boot is completed, the master starts to send telegrams permanently. From that moment, all "bus err" LEDs of the SERCOS clients (PacDrive controller, servo amplifier, ...) should be OFF.



### NOTE

During the boot, the state of the "bus err" LED is undefined. You can see from the "err" LED when the boot is completed.

The "err" LED is switched on after starting the BIOS. After loading operating system, user configuration, user parameters and IEC program and successfully starting the IEC program, the "err" LED is switched off again. The booting procedure is thus completed.

**Functioning** If the fiber-optic loop is closed and there is optimum luminous power on the receiver, the LED is off.

If the luminous power on the receiver is too high or too low (strong damping), the LED starts to shine (not very bright).

The more luminous power reaches the receiver, the brighter the LED.

If the fiber-optic loop is interrupted, the LED is the brightest.

Flashing or permanent light indicates a problem on the SERCOS input of the unit.

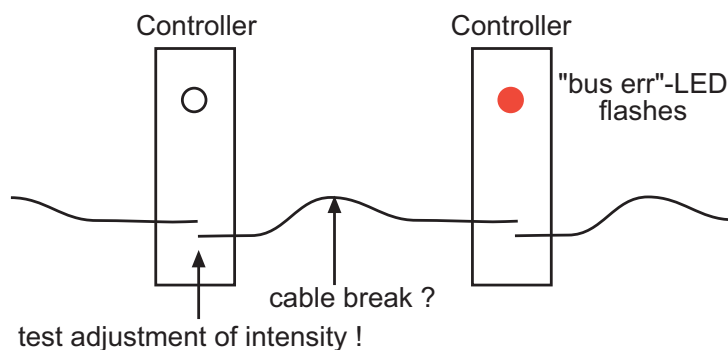

Fig. 8-1: "bus err" LED flashing

**err LED of the PacDrive controllers (SERCOS master)**

In conjunction with the "err" LED, further problems can be identified in the loop.

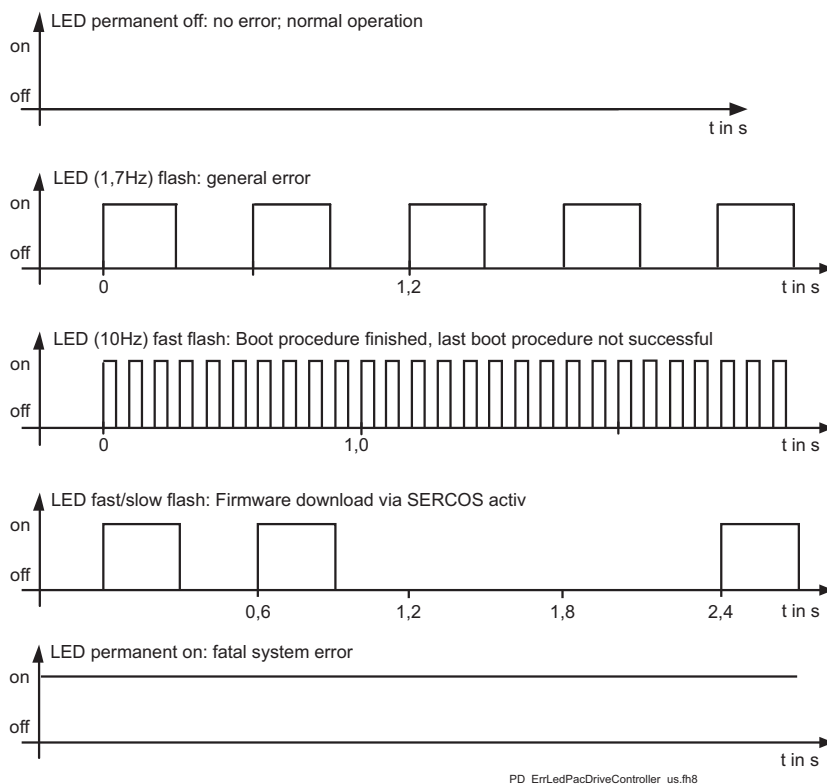

Fig. 8-2: State of the diagnosis LED "err" of the PacDrive controller

PD\_Diagnose\_us\_fm

### err LED of the slave units (e.g. MC-4)

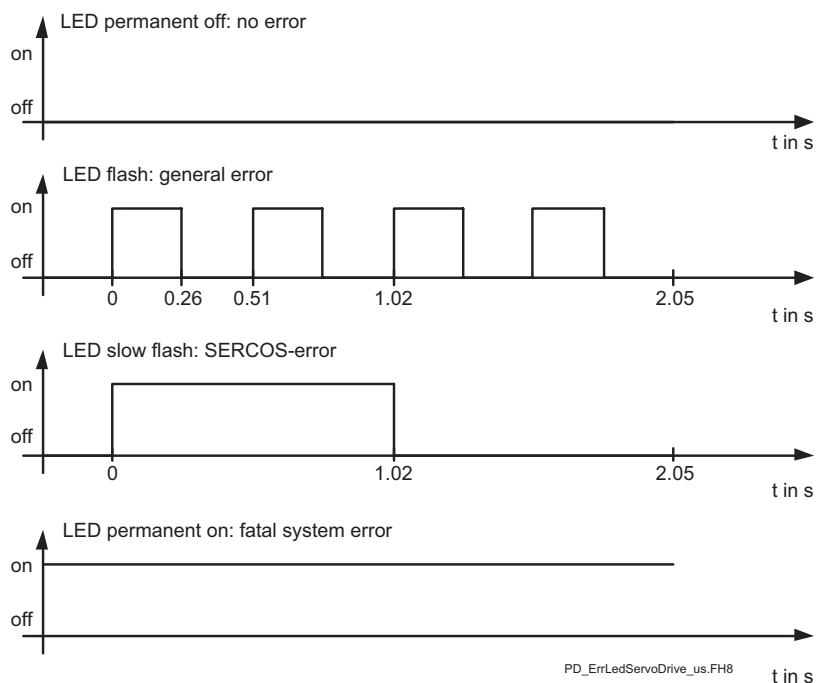

Fig. 8-3: State of the diagnosis LED "err" of the SERCOS slave units (e.g. MC-4).

#### 8.2.1 Typical Error Profile

1 device: err LED is permanently on

1 device: err LED is permanently off

See also:

- 502 loop not closed on page 93
- 505 single SERCOS cycle error on page 94
- 506 multiple SERCOS cycle error on page 95
- Parameter intensity
- Switch S3 on MC-4 servo amplifier (see Operating Manual MC-4)
- Project Manual, chapter "Wiring notes"
- Operating Manuals, "err" LED

## 8.3 Diagnosis Messages

### 8.3.1 Diagnosis Group 1XX - Servo Amplifiers

#### 100 I<sup>2</sup>T motor

- diagnosis class (default): 2
- quitable (default): yes
- reaction: B

The motor is overloaded or the power transmitted to the motor is too high. The integrator (See Control Configuration, Parameter I2t) increased to 100%.

The motor i2t is monitored with the help of an integrator, which is determined by the following equations:

$$\ddot{u} = \frac{I_{\text{aktuell}}}{I_{NM}} \quad \Delta t_{an} = 45s \times \frac{1}{\ddot{u}^2 - 1} \quad \Delta t_{ab} = 45s \times \frac{1}{1 - \ddot{u}^2}$$

- $I_{\text{aktuell}}$  actual current
- $I_{NM}$  rated motor current  
(from V00.11.00 the I<sub>om</sub> / I<sub>nm</sub> demarcation line is taken into account.)
- $t_{an}$  time of increase
- $t_{ab}$  time of decrease

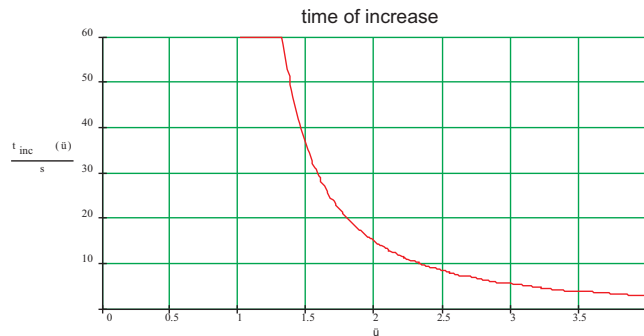

Fig. 8-4: Diagnosis message I<sup>2</sup>T motor / time of increase

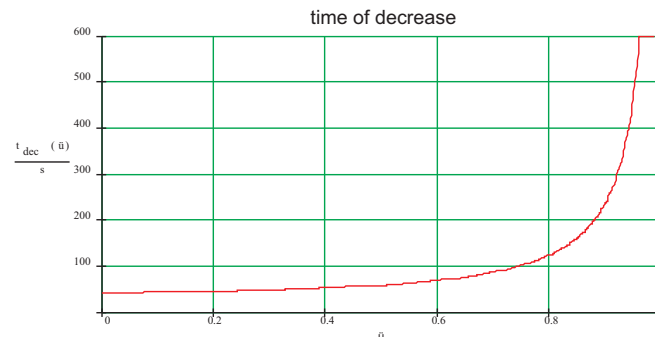

Fig. 8-5: Diagnosis message I<sup>2</sup>T motor / time of decrease

**Cause:** The holding brake is not lifted (broken cable, voltage outside the range of 22 ... 33 V).

**Solution:** Check brake and wiring.

**Cause:** Defective lubricating system.

**Solution:** Check lubrication.

**Cause:** Blunt tool.

**Solution:** Check and/or exchange tool.

**Cause:** Motor oscillating.

**Solution:** Check controller parameters.

**Cause:** Pendant axis too heavy or weight balancing defective.

**Solution:** Check drive dimensioning and weight balancing.  
Reduce driving or acceleration speed of the system.

**Cause:** Motor demagnetized.

**Solution:** Exchange motor.

#### **101 amplifier - PowerOff due to excess temperature**

- diagnosis class (default): 2
- quitable (default): yes
- reaction: B

The heat sink of the MC-4/SCL/PS-4 is too hot.

**Cause:** The end stage or rectifier overloaded.

**Solution:** Check motor / actuator combination.

Check calculation of motor and actuator.

**Cause:** Insufficient ventilation or too high ambient temperature.

**Solution:** Check device fan and ventilation holes (if any).

Check ventilation of the switching cabinet.

Check function of the air conditioning unit.

**Cause:** Hardware error: Temperature sensor defective.

**Solution:** Exchange unit.

#### **102 motor - PowerOff due to excess temperature**

- diagnosis class (default): 2
- quitable (default): yes
- reaction: B

Internal motor temperature (temperature switch inside the motor) is too high for at least 2 seconds (approx. 130°C).

**Cause:** Wiring error: Temperature switch in the motor winding connected incorrectly.

**Solution:** Check wiring.

**Cause:** Wiring error: Motor cable shield applied incorrectly.

**Solution:** Check shield clamp on the bottom side of the MC-4 servo amplifier and in the plug-in junction box of the SM motor.

**Cause:** Holding brake not lifted.

**Solution:** Lift brake.

- Cause:** Motor overloaded.
- Solution:** Drive system more slowly, check drive dimensioning, maybe use a larger motor for this application.
- Cause:** Commutation error, i.e. encoder is not matched or trimmed.
- Solution:** Match and/or trim encoder.
- Cause:** Hardware error: Defective temperature switch in the motor winding.
- Solution:** Exchange motor or send for repair.

### 103 PowerOff due to cooling error

- diagnosis class (default): 2
- quitable (default): yes
- reaction: B

The internal temperature of the unit is too high. In case of an SCL, the internal power supply unit can also be overloaded.

- Cause:** Insufficient ventilation or too high ambient temperature.
- Solution:** Check device fan and ventilation holes (if any).  
Check ventilation of the switching cabinet.
- Cause:** Hardware error: Temperature sensor defective.
- Solution:** Exchange unit.

### 104 PowerOff due to control voltage error

- diagnosis class (default): 2
- quitable (default): yes
- reaction: B

The control voltage is not correct.

- Cause:** Control voltage is too low or 24 V DC temporarily dropped.
- Solution:** Check 24 V control voltage.

### 105 feedback error (trace monitoring)

- diagnosis class (default): 1
- quitable (default): yes
- reaction: A

A hardware encoder error occurred.

Wiring error: Encoder cable defective or disconnected from encoder, servo amplifier or PacDrive controller.

- Solution:** Check encoder cable and exchange if necessary - check mass connection (shield).
- Cause:** Control voltage not applied or incorrect.
- Solution:** Check encoder voltage (see also encoder documentation).
- Cause:** Hardware error: Encoder defective.
- Solution:** Exchange encoder.



**106 communication error DC-circuit controller**

- diagnosis class (default): 2
- quitable (default): yes
- reaction: A

A system error occurred.

**Cause:** EMC problems.

**Solution:** Reset PacDrive system (PacDrive controller and servo amplifier).

**Cause:** Hardware error: Servo amplifier defective.

**Solution:** Exchange servo amplifier.

**107 excess current**

- diagnosis class (default): 1
- quitable (default): yes
- reaction: A

The current over the end stage of the servo amplifier is too high.

**Cause:** Wiring error: Motor cable is connected incorrectly or has a short-circuit.

**Solution:** Check wiring.

**Cause:** Power regulation parameters are not correct.

**Solution:** Check power regulation parameters.

**Cause:** Commutation error, i.e. encoder is not matched or trimmed.

**Solution:** Match and/or trim encoder.

**Cause:** Hardware error: Short-circuit in the motor.

**Solution:** Exchange motor.

**108 excess voltage**

- diagnosis class (default): 2
- quitable (default): yes
- reaction: A

DC-circuit voltage is too high (more than 860 V DC).

**Cause:** Wiring error: Bleeder not connected.

**Solution:** Connect bleeder.

**Cause:** The brake energy of the motor fed back into the DC-circuit is too high, which causes the voltage to rise.

**Solution:** Brake more slowly.  
Check dimensioning of the bleeder.

**Cause:** Mains voltage too high.

**Solution:** Check mains feed.

**Cause:** Hardware error: Servo amplifier defective.

**Solution:** Exchange servo amplifier.

### 109 under voltage

- diagnosis class (default): 2
- quitable (default): yes
- reaction: B

DC-circuit voltage is too low (less than 450 V DC).

**Cause:** Mains voltage too low.

**Solution:** Check mains voltage (see also Technical Data).

**Cause:** In case of parallel DC-circuits, one servo amplifier has an error.

**Solution:** Look for the servo amplifier with the error and solve the error.

### 110 phase error (power supply)

- diagnosis class (default): 2
- quitable (default): yes
- reaction: B

Failure of one phase (or two) of the mains connection of the servo amplifier. Warning 131 must first have existed for at least 10 s.

**Cause:** Wiring error: Not all phases connected correctly or mains contactor wired incorrectly.

**Solution:** Check wiring.

**Cause:** External fuse reacted.

**Solution:** Check fuse.

### 111 excessive following error

- diagnosis class (default): 2
- quitable (default): yes
- reaction: B

A very big following error has occurred.

**Cause:** Usually this error only occurs in combination with CAM functions.

**Solution:** Check cam data.

**Cause:** The axis should be run with revolution control.

**Solution:** Set parameter Pos\_P\_Gain to "0".

### 112 communication error real-time bus

- diagnosis class (default): 2
- quitable (default): yes
- reaction: B

The servo amplifier received a wrong telegram via real-time bus.

**Cause:** Intensity of fiber-optic signal from the predecessor is too low or too high.

**Solution:** Set intensity according to configuration (see Control Configuration).

**Cause:** Hardware error: Fiber-optic cable defective or weak signal due to aging.

**Solution:** Exchange fiber-optic cable; it may be sufficient to increase the intensity.

**Cause:** Hardware error: PacDrive controller and/or servo amplifier defective.

**Solution:** Exchange PacDrive controller and/or servo amplifier.

#### **113 bleeder defective**

- diagnosis class (default): 1
- quitable (default): yes
- reaction: A

The brake resistor (bleeder) is checked for functionality.

**Cause:** Wiring: Short-circuit in bleeder or cable.

**Solution:** Check bleeder and cables.

**Cause:** Wrong dimensioning of bleeder (too low Ohm value).

**Solution:** Check bleeder dimensioning (see also Project Manual and Technical Data).

**Cause:** Hardware error: Bleeder defective.

**Solution:** Measure brake resistance and exchange bleeder, if necessary.

**Cause:** Hardware error: Servo amplifier defective.

**Solution:** Exchange servo amplifier.

#### **114 reading error EEPROM**

- diagnosis class (default): 1
- quitable (default): yes
- reaction: A

Check sum in EEPROM is wrong.

**Cause:** Hardware error: EEPROM defective.

**Solution:** Please contact our customer service.

#### **116 commutation error**

- diagnosis class (default): 2
- quitable (default): yes
- reaction: A

Commutation cannot be detected.

**Cause:** Motor is turning during MC-4 boot.

**Solution:** Make sure that the motor is standing during the MFC-4 boot.

**Cause:** Wiring error: Encoder cable not connected or defective.

**Solution:** Check wiring.

#### **117 reading error encoder EEPROM**

- diagnosis class (default): 1
- quitable (default): yes
- reaction: A

No correct data can be read from the encoder EEPROM.

**Cause:** Wiring error: Incorrect encoder cable.

**Solution:** Check wiring.

**Cause:** Hardware error: Encoder defective.

**Solution:** Exchange motor and/or encoder.

### **118 error on serial interface to encoder**

- diagnosis class (default): 1
- quitable (default): yes
- reaction: A

Data transmission to the encoder is disturbed.

- Cause:** Wiring error: Encoder cable defective.
- Solution:** Check encoder cable and exchange, if necessary - check mass connection (shield); check bridge in the connector of the encoder cable
- Cause:** Control voltage not applied or incorrect.
- Solution:** Check encoder voltage (see also encoder documentation).
- Cause:** Hardware error: Encoder defective.
- Solution:** Exchange motor and/or encoder.

### **119 short-circuit or short to ground in the end stage**

- diagnosis class (default): 1
- quitable (default): yes
- reaction: A

The system checks for a short-circuit (phase short-circuit) of the motor cables or the motor.

- Cause:** Wiring error: Short-circuit in motor cable.
- Solution:** Exchange motor cable.
- Cause:** Hardware error: Short-circuit in motor (phase/phase, phase/encoder)
- Solution:** Exchange motor.
- Cause:** Hardware error: End stage in servo amplifier defective.
- Solution:** Exchange servo amplifier.

### **120 overload PowerOff of output stage**

- diagnosis class (default): 2
- quitable (default): yes
- reaction: B

Output stage overloaded.

- Cause:** Output stage overloaded.
- Solution:** Check motor / actuator combination.  
Check calculation of motor and actuator.  
Drive system at lower speed.
- Cause:** Motor brake not lifted.
- Solution:** Check wiring of motor brake (poles, broken cable,...)
- Cause:** Hardware error: Servo amplifier defective.
- Solution:** Exchange servo amplifier.

### **121 Bleeder temperature too high**

- diagnosis class (default): 2
- quitable (default): yes
- reaction: B

The bleeder is overloaded.

**Cause:** The drive is dimensioned wrongly.

**Solution:** Check drive dimensioning

**Cause:** Hardware error: bleeder or control is defective.

**Solution:** Contact our customer service.

### 122 max. motor speed reached

- diagnosis class (default): 2
- quittable (default): yes
- reaction: B

Actual motor speed is higher than rated motor speed.

**Cause:** Error occurs in a CAM function due to wrong cam or profile data.

**Solution:** Check cam data and program.

**Cause:** Jumps occurred in the master encoder.

**Solution:** Check master encoder.

**Cause:** The error occurs in a cam function due to an incorrect position manipulation (e.g. *SETPOS1()*)

**Solution:** Check program.

**Cause:** Hardware error: Commutation error, i.e. motor encoder (SinCos) is not matched or trimmed.

**Solution:** Contact our customer service.

### 123 error inverter enable

- diagnosis class (default): 2
- quittable (default): yes
- reaction: A

The Inverter Enable input became LOW while the drive was in regulation.



### NOTE

If the drive is stopped with *HW\_Enable* or *ControllerEnable*, the drive regulation remains active until the drive is standing and the brake has engaged (*BrakeCouplingTime*).

**Cause:** Wiring error:

**Solution:** Check wiring of Inverter Enable input.

**Cause:** Switching error: *Inverter Enable* input was set to LOW.

**Solution:** Check addressing of *Inverter Enable* input.

### 124 overload PowerOff

- diagnosis class (default): 5
- quittable (default): yes
- reaction: C

The overload function has detected an excessive torque.

**Cause:** An overload case occurs while the overload function is active.

**Solution:**

### **125 I<sup>2</sup>t motor warning**

- diagnosis class (default): 6
- quitable (default): yes
- reaction: D

Motor overloaded. The integrator (see Control Configuration, I2t) already increased to 80%. This can result in error 100 I2T motor.

See also:

- "100 I2T motor" on page - 62

### **126 amplifier excess temperature warning**

- diagnosis class (default): 6
- quitable (default): yes
- reaction: D

The heat sink of the MC-4/SCL/PS-4 gets too hot. This can result in an error 101 amplifier - excess temperature PowerOff.

See also:

- "101 amplifier - PowerOff due to excess temperature" on page - 63

### **127 motor excess temperature warning**

- diagnosis class (default): 6
- quitable (default): yes
- reaction: D

Internal motor temperature (temperature switch inside the motor) is too high (approx. 130°C). If the temperature switch inside the motor reports a too high temperature for at least 2 seconds, the error 102 motor excess temperature PowerOff is triggered.

See also:

- "102 motor - PowerOff due to excess temperature" on page - 63

### **128 cooling error warning**

- diagnosis class (default): 6
- quitable (default): yes
- reaction: D

The internal temperature of the unit is too high. In case of an SCL, the internal power supply unit can also be overloaded. This can result in an error 103 PowerOff due to cooling error.

See also:

- "103 PowerOff due to cooling error" on page - 64

**129 I<sup>2</sup>t in output stage warning**

- diagnosis class (default): 6
- quitable (default): yes
- reaction: D

Output stage overloaded. This can result in an error 120 overload PowerOff of output stage.

See also:

- "120 overload PowerOff of output stage" on page - 68

**130 bleeder temperature rising**

- diagnosis class (default): 6
- quitable (default): yes
- reaction: D

Bleeder overloaded. This can result in an error 121 bleeder temperature too high.

See also:

- "121 Bleeder temperature too high" on page - 68

**131 phase failure of power supply warning**

- diagnosis class (default): 6
- quitable (default): yes
- reaction: D

Failure of one phase (or two) of the mains connection of the servo amplifier. If this warning exists for 10 s, this leads to an error 110 phase error (power supply).

See also:

- "110 phase error (power supply)" on page - 66

**132 following error**

- diagnosis class (default): 6
- quitable (default): yes
- reaction: D

A positioning following error greater than the parameter "FollowingLimit" occurred in the position controller of the servo amplifier.

**Cause:** Following error monitoring is too intolerant.

**Solution:** Increase object parameter FollowingLimit.

**Cause:** Acceleration is too high.

**Solution:** Reduce acceleration.

**Cause:** The following error is a result of diagnosis message 100 I<sup>2</sup>T motor

**Solution:** See 100 I<sup>2</sup>T motor

**Cause:** Mechanics are tight or blocked.

**Solution:** Check motion range.

**Cause:** Incorrect parameterization.

**Solution:** Check regulator parameter and J\_Load.

- Cause:** Current feed forward is deactivated.  
**Solution:** Set parameter CurrFeedForw to "on / TRUE".
- Cause:** Wiring error: Leads in motor or encoder cable changed by mistake.  
**Solution:** Check cable connection and cable.
- Cause:** Wiring error: Wrong encoder connector or motor connector used (maybe from neighboring actuator)  
**Solution:** Check encoder and motor connectors. Check encoder and motor cables.
- Cause:** Wiring error: Holding brake not lifted.  
**Solution:** Check holding brake.
- Cause:** No mains voltage.  
**Solution:** Check mains voltage on servo amplifier.
- Cause:** An encoder with a wrong bar code was installed.  
**Solution:** Check encoder.
- Cause:** Hardware error: Loose coupling with position encoder.  
**Solution:** Check encoder coupling.
- Cause:** Hardware error: Encoder signal gives jumps.  
**Solution:** Check motion range.
- Cause:** The axis should be run with revolution control.  
**Solution:** Set parameter Pos\_P\_Gain to "0".

### 133 speed-dependent power reduction

- diagnosis class (default): 7
- quitable (default): yes
- reaction: E

From a speed of < 75 rpm (112.5 rpm for SR058, 150 rpm for SM070) the maximum motor current is limited to 70% of DrivePeakC. This is a safety measure to protect the motor when driving to block.

In versions V00.11.00 or higher, this message is not generated until the set current is really limited to 70% of DrivePeakC.

In older versions, the message is generated as soon as the limitation has been activated, even if the set current is below 70% of DrivePeakC.

- Cause:** Axis driven to block.  
**Solution:** Check motion range of the axis.

### 134 external 24V power supply too low

- diagnosis class (default): 7
- quitable (default): yes
- reaction: E

Control voltage (24 V DC) is too low.

- Cause:** Control voltage too low.  
**Solution:** Check control voltage (see also Technical Data of MC-4).



**135 under voltage warning**

- diagnosis class (default): 6
- quitable (default): yes
- reaction: D

The system tries to start the drive, but the DC-circuit voltage is too low (below 450 V DC).

**Cause:** Hardware Enable and Software Enable are there, but the mains voltage is too low.

**Solution:** Check mains voltage (see also Technical Data of MC-4); possibly the mains contactor is not activated.

**Cause:** In case of parallel DC-circuits, one servo amplifier has an error.

**Solution:** Look for the servo amplifier with the error and solve the error.

**136 Inverter Enable warning**

- diagnosis class (default): 6
- quitable (default): yes
- reaction: D

Attempt to start the drive, but Inverter Enable is still LOW.

**Cause:** Hardware Enable and Software Enable are active, but Inverter Enable is still LOW.

**Solution:** Activate Inverter Enable.

**137 motorless**

- diagnosis class (default): 2
- quitable (default): yes
- reaction: A

When switching the MC-4 servo amplifier from motorless to normal operation, the system reports a motor error that occurred in the meantime.

Motor errors resulting in the diagnosis message are:

- 102 motor - PowerOff due to excess temperature“ on page - 63
- 111 excessive following error“ on page - 66
- 116 commutation error“ on page - 67
- 122 max. motor speed reached“ on page - 69
- 105 feedback error (trace monitoring)“ on page - 64
- 117 reading error encoder EEPROM“ on page - 67
- 118 error on serial interface to encoder“ on page - 68

The error messages listed above are suppressed in motorless operation (parameter motorless = yes) and result in error message 137 motorless when switching back to normal operation (parameter motorless = no).

Please note that diagnosis messages 105, 117 and 118 will also result in diagnosis message 137 motorless if they occurred in normal operation, you then switched to motorless operation and back to normal operation.

- Cause:** A motor error has occurred.
- Solution:** The servo amplifier can only be freed from this state if you execute a hardware reset on the MC-4 or set the MC-4 back to *motorless*.
- Cause:** The MC-4 was not switched off when connecting a motor to a servo amplifier parameterized to *motorless*. After that, the servo amplifier was switched to normal operation.
- Solution:** The servo amplifier can only be freed from this state if you execute a hardware reset on the servo amplifier or set the servo amplifier back to *motorless*.

### 138 impermissible motor

- diagnosis class (default): 1
- quitable (default): yes
- reaction: A

An impermissible motor is connected to the servo amplifier.

- Cause:** An SM 070 60 010 is connected to the MC-4 / 22 A.
- Solution:** Use a "bigger" motor (e.g. SM 070 60 020) or a "smaller" servo amplifier (e.g. MC-4 / 10 A).
- Cause:** An SM 070 60 010, SM 070 60 020 or SM 100 50 030 is connected to an MC-4 / 50 A.
- Solution:** Use a "bigger" motor (e.g. SM 100 40 050) or a "smaller" servo amplifier (e.g. MC-4 / 10 A).

### 139 error in DC-circuit charge

- diagnosis class (default): 2
- quitable (default): yes
- reaction: B

The error message is generated if a 3-phase mains voltage is applied and the DC-circuit voltage of 450 V DC is not reached within one second after activating the mains phases. The setting of the parameter PhaseCheck has no effect on this error check.

This check prevents a thermal destruction of the bleeder.

- Cause:** The parameter DC\_LowCheck is "off"
- Mains voltage drops (i.e. drive remains in regulation)
- Mains voltage is activated again (drive is still in regulation) while e.g. a load is exercising force on the axis.
- Solution:** Prevent disconnection of mains voltage while the drive is in regulation.
- Deactivate the regulation or output stage when deactivating the mains contactor (parameter ControllerEnable or input *enable* on the servo amplifier).

**140 stop time limit**

- diagnosis class (default): 2
- quittable (default): yes
- reaction: B

The stop time limit was exceeded when ramping down the motor in a controlled way.

**Cause:** The load on the drive is too large to be able to observe the set stop time limit.

**Solution:** Check the parameter StopTimeLim in the control configuration.

If the diagnosis message occurs in connection with the overload functions, please note that in this case the stop time limit is set firmly to 800 ms. In this case, you need a stronger motor / servo amplifier combination.

**Cause:** Encoder in the motor is defective (or commutation is not ok).

**Solution:** Exchange motor.

**141 reading error EncoderPosition**

- diagnosis class (default): 5
- quittable (default): yes
- reaction: D

The error occurred when reading the matching position from the motor encoder.

**Cause:** The function *DrvEncSetPosition* was called up and could not be processed correctly.

**Solution:** Call up the function *DrvEncSetPosition* again.

**Cause:** Encoder in the motor is defective.

**Solution:** Exchange motor.

**142 board - PowerOff due to excess temperature**

- diagnosis class (default): 2
- quittable (default): yes
- reaction: B

The temperature of the board inside the casing is too high.

**Cause:** Insufficient ventilation or too high ambient temperature.

**Solution:** Check device fan and ventilation holes (if any).

Check ventilation of the switching cabinet.

Check function of the air conditioning unit.

**Cause:** Hardware error: Temperature sensor defective.

**Solution:** Exchange unit.

See also:

- 161 board excess temperature warning on page 80

### 143 encoder temperature warning

- diagnosis class (default): 6
- quitable (default): yes
- reaction: D

The temperature inside the encoder is too high.

**Cause:** Insufficient ventilation or too high ambient temperature.

**Solution:** Check device fans and ventilation holes (if any).

Check ventilation of the switching cabinet.

Check function of the air conditioning unit.

**Cause:** Hardware error: Temperature sensor defective.

**Solution:** Exchange unit.

### 144 DC short-circuit

- diagnosis class (default): 1
- quitable (default): no
- reaction: A

A short-circuit occurred in the DC-circuit.

**Cause:** Wiring error: Short-circuit in the cable.

**Solution:** Check cable and exchange, if necessary.

### 145 DC short to ground

- diagnosis class (default): 1
- quitable (default): no
- reaction: A

A short to ground has occurred.

**Cause:** Wiring error:

**Solution:** Check cable and exchange, if necessary.

### 146 DC-circuit overload

- diagnosis class (default): 1
- quitable (default): yes
- reaction: B

DC-circuit overloaded.

**Cause:** Too many sinks (e.g. ServoDrive SCL) on the DC-circuit.

**Solution:** Use another PS-4 power supply unit and split up power supply to the sinks.

The existing constellation may be sufficient if the application is modified (e.g. lower acceleration).

See also

- 157 warning DC-circuit overload on page 79
- DC\_BusOverload

**147 24V power supply overload**

- diagnosis class (default): 1
- quitable (default): yes
- reaction: B

The 24V power supply for the ServoDrives SCL are overloaded.

**Cause:** Wiring error: A DC-circuit has occurred.

**Solution:** Check wiring of 24V power supply.

**Cause:** Too many sinks (e.g. ServoDrive SCL) connected to the 24V power supply.

**Solution:** Use another PS-4 power supply unit and split up power supply to the sinks.

See also:

- 158 warning 24V power supply overload on page 79  
Parameter DC\_BusCurrent

**148 internal voltage error 15V**

- diagnosis class (default): 1
- quitable (default): no
- reaction: A

Internal 15V voltage too low.

**Cause:** Defective unit.

**Solution:** Exchange unit.

**149 internal voltage error 12V**

- diagnosis class (default): 1
- quitable (default): yes
- reaction: B

Internal 12V voltage too low.

**Cause:** Defective unit.

**Solution:** Exchange unit.

**150 phase failure L1**

- diagnosis class (default): 1
- quitable (default): yes
- reaction: B

Failure of phase L1 of the mains connection of the unit.

**Cause:** Wiring error: The phase not connected correctly or mains contactor not wired correctly.

**Solution:** Check wiring.

**Cause:** External fuse reacted.

**Solution:** Check fuse.

See also:

- 154 warning phase failure L1 on page 78  
Parameter PhaseCheckMode

### 151 phase failure L2

- diagnosis class (default): 1
- quitable (default): yes
- reaction: B

Failure of phase L2 of the mains connection of the unit.

**Cause:** Wiring error: Phase not connected correctly or mains contactor not wired correctly.

**Solution:** Check wiring.

**Cause:** External fuse reacted.

**Solution:** Check fuse.

See also:

- 155 warning phase failure L2 on page 79  
Parameter PhaseCheckMode

### 152 phase failure L3

- diagnosis class (default): 1
- quitable (default): yes
- reaction: B

Failure of phase L3 of the mains connection of the unit.

**Cause:** Wiring error: Phase not connected correctly or mains contactor not wired correctly.

**Solution:** Check wiring.

**Cause:** External fuse reacted.

**Solution:** Check fuse.

See also:

- 156 warning phase failure L3 on page 79  
Parameter PhaseCheckMode

### 153 DC-circuit discharge error

- diagnosis class (default): 1
- quitable (default): yes
- reaction: B

The DC-circuit is not discharged correctly.

**Cause:** Defective unit.

**Solution:** Exchange unit.

See also:

- Parameter DC\_BusDischarge

### 154 warning phase failure L1

- diagnosis class (default): 6
- quitable (default): yes
- reaction: D

Phase L1 of the mains connection of the unit has failed. If the warning remains for 10 s, this results in error 150 phase failure L1.

See also:

- 150 phase failure L1 on page 77 Parameter PhaseCheckMode

**155 warning phase failure L2**

- diagnosis class (default): 6
- quitable (default): yes
- reaction: D

Failure of phase L2 of the mains connection of the unit. If this warning exists for 10 s, this leads to an error 151 phase failure L2.

See also:

- 151 phase failure L2" on page - 78 Parameter PhaseCheckMode

**156 warning phase failure L3**

- diagnosis class (default): 6
- quitable (default): yes
- reaction: D

Failure of phase L3 of the mains connection of the unit. If this warning exists for 10 s, this leads to an error 152 phase failure L3.

See also:

- 152 phase failure L3" on page - 78 Parameter PhaseCheckMode

**157 warning DC-circuit overload**

- diagnosis class (default): 6
- quitable (default): yes
- reaction: D

The DC-circuit is 80% overloaded. This is indicated with the parameter DC\_BusOverload. If the overload rises to 100%, error message 146 DC-circuit overload is triggered.

See also:

- 146 DC-circuit overload on page 76 DC\_BusOverload

**158 warning 24V power supply overload**

- diagnosis class (default): 6
- quitable (default): yes
- reaction: D

The 24V power supply for the ServoDrives SCL is 80% overloaded. If the overload rises to 100%, error message 147 24V power supply overload is triggered.

See also:

- 147 24V power supply overload on page 77  
Parameter DC\_BusCurrent

**159 warning DC-circuit not discharged**

- diagnosis class (default): 6
- quitable (default): yes
- reaction: D

The system tries to discharge the DC-circuit, but the mains voltage is still on.

**Cause:** Wiring error: The mains contactor is not discharged correctly.  
**Solution:** Check wiring.

See also:

- Parameter DC\_BusDischarge

### **160 under voltage output stage driver**

- diagnosis class (default): 1
- quitable (default): no
- reaction: A

The supply voltage of the output stage drivers is too low.

**Cause:** Hardware error: Defective unit.  
**Solution:** Exchange unit.

### **161 board excess temperature warning**

- diagnosis class (default): 6
- quitable (default): yes
- reaction: D

The temperature of the board inside the casing is too high. If the temperature rises further, diagnosis message 142 board - PowerOff due to excess temperature is triggered.

See also:

- 142 board - PowerOff due to excess temperature on page 75

### **162 wiring error O\_0**

- diagnosis class (default): 5
- quitable (default): yes
- reaction: B

There is a connection error.

**Cause:** There is a short-circuit or overload on the corresponding output.  
**Solution:** Check wiring of the output.



## 8.3.2 Diagnosis Group 2XX Object Administration

### 200 faulty logic address of the parameter

- diagnosis class (default): 4
- quitable (default): yes

The object or parameter to be accessed does not exist.

**Cause:** The IEC program addresses an object or parameter that does not exist.

**Solution:** Check program.

Please contact our application department.

**Cause:** Following error of diagnosis message 209 last boot failed.

**Solution:** See 209 last boot failed on page 83

### 201 faulty parameter type code

- diagnosis class (default): 4
- quitable (default): yes

The type code of a parameter is not correct.

**Cause:** Software error.

**Solution:** Contact our application department.

### 204 IEC program cannot be loaded

- diagnosis class (default): 4
- quitable (default): yes

The IEC program cannot be loaded.

Further information to narrow down the error can be found in DiagExtCode or the message logger.

DiagExtCode	Meaning
prog xhhhhhhh	IEC program code too big
bad version	IEC program not compatible with PacDrive controller firmware (V00.10.00 or higher)
data xhhhhhhh	IEC data range too big -> adjust number of data segments
ret xhhhhhhh	retain range too big
...other	other file error

Fig. 8-6: Meaning of DiagExtCodes

#### Cause for "data xhhhhhhh":

A project was developed for an older PacDrive controller firmware. The number of data segments in the project has a value greater than two (e.g. three). If the program is now transmitted to the controller, EPAS-4 will issue the following message after the transmission: "Error when loading the program!"

**Solution:** In this case the number of data segments has to be reduced to two and the project has to be recompiled and retransmitted to the controller.

**Cause:** There is no IEC program in the PacDrive controller or the IEC program is defective or incompatible.

**Solution:** Retransmit the IEC program with EPAS-4.

**Cause:** IEC program code, IEC data range or IEC retain range in PacDrive controller too large.

See also:

- DiagExtCode

**Solution:** Adjust project.

**Cause:** The setting under "number of data segments" in EPAS-4 PROJECT | OPTIONS | Compilation options is less than 2 (DiagExtCode = ret xhhhhhhh).

**Solution:** Increase number of data segments.

### **205 illegal parameter value**

- diagnosis class (default): 4
- quitable (default): yes

A parameter has an illegal value. Use the parameter DiagExtCode in the control configuration or the message logger to detect the logic address of the parameter with the illegal value. Thus it can be assigned to the control configuration.

**Cause:** Ext. diagnosis: BaudRate=<illegal value>M

In V00.15.00 or higher, the PacDrive controller supports the SERCOS parameter BaudRate. The values 2, 4, 8 and 16 Mbaud are generally supported.

Depending on the type of PacDrive controller (Max-4, CXX, PXX, ...) only certain values are supported. The value is checked dynamically while writing. Faulty values will not be accepted. Diagnosis message 205 illegal parameter value will be triggered.

**Solution:** Enter valid value for BaudRate.

**Cause:** I=0Bxx0004; i.e. a too low or too high value for Acceleration has been entered in the virtual encoder.

**Solution:** Enter valid value for Acceleration.

**Cause:** I=03xx0025; i.e. J\_Load in the control configuration is too high.

**Solution:** Enter valid value for J\_Load.

**Cause:** I=01000004; i.e. IP\_Gateway in the control configuration does not match IP\_SubNetMask.

**Solution:** Observe conventions of IP address nomenclature.

### **207 hardware module does not exist**

- diagnosis class (default): 4
- quitable (default): no

A hardware module that does not exist in the real system was entered in the control configuration. Use the parameter DiagExtCode in the

control configuration or message logger to determine the type of the hardware module.

**Cause:** An analog input or physical encoder that does not exist was entered in the control configuration.

**Solution:** Check control configuration.

See also:

- Parameter Mx4Type
- Parameter Opt1Type
- Parameter Opt2Type
- Parameter Opt3Type

**Cause:** Hardware error: Hardware module not recognized or defective.

**Solution:** Exchange PacDrive controller / PacPC or optional module.

### 208 too many real axes in configuration

- diagnosis class (default): 4
- quitable (default): no

The number of axes in the control configuration is too high.



#### NOTE

With V00.15.00 or higher, this diagnosis message is substituted by diagnosis message 518 "too many real SERCOS slaves" on page - 98.

**Cause:** The number of axes is too high for the cycle time.

**Solution:** Check CycleTime.

**Cause:** The number of axes per PacDrive controller is limited.

**Solution:** Check PacDrive controller type on the type plate.

### 209 last boot failed

- diagnosis class (default): 4
- quitable (default): no

During the last boot, the control voltage of the PacDrive controller / PacPC collapsed or the PacDrive controller / PacPC was reset or a serious error occurred. The problem can be narrowed down with the help of DiagExtCode.

During the boot, the PacDrive controller protocols the individual phases in the NvRam. If a serious error occurs (err LED permanently ON), the next boot will only boot with the basic configuration and diagnosis message 209 will be triggered.



**CAUTION!**

The minimal boot of the PacDrive controller / PacPC sets the configuration and parameters of the control configuration to default values!

TCP/IP address is on default value!

No configured modem available!

Following errors (e.g. diagnosis messages 200 and 206) occur when loading the IEC program.



**CAUTION!**

The third boot will be a normal boot again.

If this does not work, the basic configuration will be active again for the next boot, and so on... !

DiagExtCode	Meaning
1	start of boot before kernel init
2	kernel init completed; FTP server priority adjusted; time slicing on; system clock; no. of ticks per second set
3	init logger and NvRam terminated; interrupts locked
31	before ScanDisk
4	diagnosis created, messages sent, before ObjectContr new
10	begin constructor ObjVerObjektContr; task lock active
11	config and par files read
12	config file evaluated, before object generation
13	after object generation
14	after setting CycleTime
15	after init of Moni.Max, LogEnc, VirtEnc, PhyEnc, construction of RTP before pointer tab assignment
16	after setting parameters
17	after SERCOS boot
18	after start of runtime system
19	after RTP start, before loading IEC program
20	after loading IEC program
5	after ObjectContr new
6	after axis enable, before WatchDogOn
RAM < 32MB	RAM in PacDrive controller not sufficient

**Method:** EPAS-4 connection with TCP/IP default address or serial  
 Read and evaluate message logger (important DiagExtCode!)  
 DiagExtCode indicates which phase was last executed correctly.  
 See also:

- 200 faulty logic address of the parameter“ on page - 81
- Group 800 - System Errors

**NOTE**

If the PacDrive controller /PacPC booted in minimal configuration (LED flashing fast), parameters and configuration are always offered for download when logging in with EPAS-4 (V00.07.00 or higher).

This does not indicate a different state of the files on the PacDrive controller / PacPC!

Since the PacDrive controller / PacPC booted with the default configuration, downloading an IEC program may result in diagnosis message 206 faulty type code in LogAdr, as the program uses parameters that are not available.

**Cause:** *DiagExtCode* = 19: Program error, i.e. faulty IEC program file

**Solution:** Overwrite the IEC program on the PacDrive controller / PacPC by transmitting an IEC project (dummy) with the basic configuration.

Check your program and transmit a fault-free program to the PacDrive controller / PacPC.

**Cause:** *DiagExtCode* is not 19.

**Solution:** Contact our application department.

**Cause:** PacDrive controller was booted twice within a short time. This can happen e.g. if the reset button is pressed twice or the control voltage collapses.

**Solution:** Check control voltage (see also Technical Data).

**Cause:** The RAM in the PacDrive controller is not sufficient for the project (*DiagExtCode*=out of memory).

**Meaning** A memory request could not be executed. Memory requests are issued when booting, resetting the IEC task, calling up system components, setting/reading parameters, establishing and disconnecting an FTP connection and transmitting data (remote device), when communicating with EPAS-4, establishing and disconnecting a dial-up connection and during telecommunication.

**Solution:** Reduce configuration, reduce RamDiskSize, reduce number of tasks, maybe use a PacDrive controller / PacPC with bigger RAM.

**Cause:** A PacDrive controller version 00.15.00 or higher is used.

With that version, the user data area was increased from 2 MB to 3.7 MB. If the PacDrive controller has less than 32 MB RAM, it goes to minimal boot.

**Solution:** Use a PacDrive controller with at least 32 MB RAM or a firmware version prior to V00.15.00.

### 8.3.3 Diagnosis Group 3XX - General

#### 300 division error

- diagnosis class (default): 4
- quitable (default): no

A division by 0 was attempted in the IEC program.



---

#### NOTE

Division by 0 is defined for REAL and LREAL and therefore causes no diagnosis message 300 division error.

---

**Cause:** In an IEC division function, the divisor was zero.

**Solution:** Avoid division by 0 in the IEC program. Check numerical range.

#### 313 serious cycle time overrun

- diagnosis class (default): 4
- quitable (default): no

The serious cycle time overrun of an IEC task is triggered if the 10-fold cycle time (see Task Configuration) is exceeded.

The task moves to error state. This state can only be quitted by an IEC task reset. The cycle time monitor of the IEC tasks refers to the parameter Load, which is shown in the expansion object IEC Task.

**Cause:** Call of a parameter or system component that takes "very long" to process.

**Solution:** Check the program (e.g. access to SERCOS parameters -> see Types of Object Parameters or function WaitTime()).

**Cause:** Time interval in the task configuration too short.

**Solution:** Check task configuration.

#### 314 defective program file (only versions below 00.07.00)

- diagnosis class (default): 4
- quitable (default): yes

A system error occurred.

**Cause:** The check sum of the program is incorrect.

**Solution:** Retransmit program.

#### 315 library function not implemented

- diagnosis class (default): 4
- quitable (default): yes

The program uses an interface library that is not or not fully supported in the actual PacDrive controller / PacPC. (function name see DiagExtCode)

**Cause:** Firmware in PacDrive controller / PacPC too old.

**Solution:** Use other library function or update firmware in PacDrive controller / PacPC.

**316 faulty NvRam CRC**

- diagnosis class (default): 6
- quitable (default): yes

The NvRam lost the data, i.e. data in the message logger and IEC variable values have been deleted.

**Cause:** Object in message logger: MAX4

PacDrive controller was not switched on for more than 7 days (control voltage!).

**Solution:** Reboot PacDrive controller. Now the error must not occur any more.

**Cause:** Object in message logger: PN4

Internal or external battery on optional module PN-4 is empty and PacDrive controller was not switched on for more than 7 days (control voltage!).

**Solution:** Reboot PacDrive controller. Now the error must not occur any more.

**Cause:** Object in message logger: MAX4

Ext. diagnosis in message logger: Nvram damaged  
The NvRam on the PacDrive controller is damaged.

**Solution:** Exchange PacDrive controller.

**Cause:** Object in message logger: PN4

Ext. diagnosis in message logger: Nvram damaged  
The NvRam on the optional module PN-4 is damaged.

**Solution:** Exchange optional module PN-4.

**Cause:** Hardware error: Buffer capacitor defective.

**Solution:** Exchange PacDrive controller.

**317 cycle time overflow**

- diagnosis class (default): 6
- quitable (default): yes

A "minor" cycle time overflow was detected. It is triggered if the cycle time is exceeded by more than 250  $\mu$ s. DiagExtCode contains the actual cycle time / cycle time from task configuration in ms.

See also:

- 313 serious cycle time overrun on page 86

**318 calculated profile deleted**

- diagnosis class (default): 5
- quitable (default): yes

The system tried to calculate a profile (e.g. CamMasterStart()) that is just being deleted with the function ProfilDelete(). In DiagExtCode the *ProfileId* is shown in hexadecimal form (e.g. Prof=10010000).

**Cause:** Programming error: The profile to be calculated was deleted too early or the wrong profile was deleted.

**Solution:** Check program.

### 319 TPEdge inaccurate at 4ms

- diagnosis class (default): 2
- quitable (default): yes

Touchprobe measurement is inaccurate at the entered CycleTime of 4 ms.

**Cause:** A CycleTime of 4 ms is entered in the control configuration, and the PacDrive controller hardware does not support touchprobe measurement correctly at that CycleTime.

**Solution:** Set CycleTime to 1 or 2 ms, if possible.

Update PacDrive controller hardware. Contact our customer service.

### 320 bad array access (check)

- diagnosis class (default): 5
- quitable (default): yes

Check.lib detected an array access error in the IEC user program. The component calls and their interlacing can be traced back with the help of the function Call Hierarchy.

**Cause:** The limits of an array were violated when accessing the array in the IEC user program.

**Solution:** Check IEC user program.

### 321 division by 0 (check)

- diagnosis class (default): 5
- quitable (default): yes

Check.lib detected a division by 0 in the IEC user program. The component calls and their interlacing can be traced back with the help of the function Call Hierarchy.

**Cause:** A division by 0 was attempted in the IEC user program.

**Solution:** Check IEC user program.

### 322 exception processing in IEC task

- diagnosis class (default): 5
- quitable (default): yes

The function SysUserCallStack() was called up. The component calls and their interlacing can be traced back with the help of the function Call Hierarchy.

**Cause:** The function SysUserCallStack() was called up in the IEC program.

**Solution:** This function should only be used in the development phase in order to solve problems.

### 323 string too long

- diagnosis class (default): 5
- quitable (default): yes

Check.lib detected an overflow of the maximum string length (255) in the IEC user program. The component calls and their interlacing can be traced back with the help of the function Call Hierarchy.



**Cause:** Maximum string length in IEC user program exceeded.

**Solution:** Check IEC user program.

### 324 UPS internal error

- diagnosis class (default): 5

- quitable (default): yes

There is an internal error in the UPS (state = 2).

**Cause:** UPS battery empty.

**Solution:** Recharge battery.

**Cause:** Power supply of UPS is ok, but UPS input "ON/OFF" is OFF.

**Solution:** With correct power supply, the input "ON/OFF" must be ON in order for the UPS function to be available.

**Cause:** A UPS object is entered in the control configuration, but no UPS is connected.

**Solution:** Connect UPS or adjust control configuration.

**Cause:** An internal error occurred in the UPS.

**Solution:** Check UPS.

### 325 corrupt file

- diagnosis class (default): 5

- quitable (default): yes

A problem (no file or CRC error) occurred when reading the retain file. If the parameter *Enable* of the UPS expansion object is set to "external / 1", the retain file is read from the flash disk when booting the PacDrive controller.

**Cause:** A UPS object is entered in the control configuration, but no UPS is connected.

**Solution:** Connect UPS or adjust control configuration.

**Cause:** Function of UPS is not ok.

**Solution:** Check function of the UPS.

### 326 function not available

- diagnosis class (default): 5

- quitable (default): yes

A function that is not supported by the PacDrive system was called up. Further information on object type and instance is shown in the message logger. DiagExtCode also indicates the cause of the error.

**Cause:** Function not supported by PacDrive controller hardware.

**Solution:** Check hardware version on the type plate and in the parameter MAX4Type.

### 327 invalid PositionSource

- diagnosis class (default): 6
- quitable (default): yes

An invalid value has been entered in CamTrack in the parameter *PositionSource*.

**Cause:** You did not enter the symbolic name of a logic encoder or an axis (MC-4 or SCL) in *PositionSource*.

**Solution:** Check value in parameter *PositionSource*.

See also:

- Parameter State

### 328 invalid destination

- diagnosis class (default): 6
- quitable (default): yes

An invalid value has been entered in CamTrack in the parameter *Destination*.

**Cause:** You did not enter the symbolic name of an output group or "none" in *Destination*.

**Solution:** Check value in parameter *Destination*.

See also Parameter State

### 329 invalid bit number

- diagnosis class (default): 6
- quitable (default): yes

An invalid value has been entered in CamTrack in the parameter *Bitno*.

**Cause:** You entered an invalid bit number in *Bitno*.

**Solution:** Check value in parameter *Bitno*.

See also Parameter State

### 330 bad master job

- diagnosis class (default): 5
- quitable (default): yes

This diagnosis message is triggered if a master positioning job of an axis could not be processed, although the range checks of the job parameters did not show any error (e.g. error in pre-calculation of generator data).

An extended diagnosis message in the format "GT=XXX,MJId=YYY" is generated. XXX is the generator type; YYY is the master job ID of the job that is causing the problem.

**Cause:** Internal calculation error.

**Solution:**

### 8.3.4 Diagnosis Group 4XX IEC Task

#### 400 IEC diagnosis message class 2

- diagnosis class (default): 2
- quitable (default): yes

The IEC program triggered a diagnosis message with the function DiagMsgWrite().

**Cause:** The error was caused by the IEC program.

**Solution:** See description of your IEC program. An additional error text can be outputted with the function DiagMsgWrite(). See also parameter *DiagMsg* in the control configuration.

#### 401 IEC diagnosis message class 3

- diagnosis class (default): 3
- quitable (default): yes

The IEC program triggered a diagnosis message with the function DiagMsgWrite().

**Cause:** The error was caused by the IEC program.

**Solution:** See description of your IEC program. An additional error text can be outputted with the function DiagMsgWrite(). See also parameter *DiagMsg* in the control configuration.

#### 402 IEC diagnosis message class 4

- diagnosis class (default): 4
- quitable (default): yes

The IEC program triggered a diagnosis message with the function DiagMsgWrite().

**Cause:** The error was caused by the IEC program.

**Solution:** See description of your IEC program. An additional error text can be outputted with the function DiagMsgWrite(). See also parameter *DiagMsg* in the control configuration.

#### 403 IEC diagnosis message class 5

- diagnosis class (default): 5
- quitable (default): yes

The IEC program triggered a diagnosis message with the function DiagMsgWrite().

**Cause:** The error was caused by the IEC program.

**Solution:** See description of your IEC program. An additional error text can be outputted with the function DiagMsgWrite(). See also parameter *DiagMsg* in the control configuration.

#### 404 IEC diagnosis message class 6

- diagnosis class (default): 6
- quitable (default): yes

The IEC program triggered a diagnosis message with the function DiagMsgWrite().

**Cause:** The error was caused by the IEC program.

**Solution:** See description of your IEC program. An additional error text can be outputted with the function `DiagMsgWrite()`. See also parameter *DiagMsg* in the control configuration.

### **405 IEC diagnosis message class 7**

- diagnosis class (default): 7
- quitable (default): yes

The IEC program triggered a diagnosis message with the function `DiagMsgWrite()`.

**Cause:** The error was caused by the IEC program.

**Solution:** See description of your IEC program. An additional error text can be outputted with the function `DiagMsgWrite()`. See also parameter *DiagMsg* in the control configuration.

### **406 IEC diagnosis message class 1**

- diagnosis class (default): 1
- quitable (default): yes

The IEC program triggered a diagnosis message with the function `DiagMsgWrite()`.

**Cause:** The error was caused by the IEC program.

**Solution:** See description of your IEC program. An additional error text can be outputted with the function `DiagMsgWrite()`. See also parameter *DiagMsg* in the control configuration.

### **407 IEC diagnosis message class 8**

- diagnosis class (default): 8
- quitable (default): yes

The IEC program triggered a diagnosis message with the function `DiagMsgWrite()`.

**Cause:** The error was caused by the IEC program.

**Solution:** See description of your IEC program. An additional error text can be outputted with the function `DiagMsgWrite()`. See also parameter *DiagMsg* in the control configuration.

### 8.3.5 Diagnosis Group 5XX Real-Time Bus / Real-Time Process

#### 500 SERCOS slave with duplicate address

- diagnosis class (default): 1
- quitable (default): yes (V00.15.00 or higher)

The addresses of the detected SERCOS slaves are checked during phase 3 of the SERCOS boot. Address multiplications are detected. However, this function must also be supported by the SERCOS slaves. ELAU slaves support this function from V00.15.00 or higher (MC-4, SCI and PS-4).

**Cause:** Duplicate SERCOS slave address.

**Solution:** Check rotary switch settings on SERCOS slaves.

#### Meaning in versions lower than V00.15.00:

A servo amplifier address was assigned two or more times in the control configuration.

**Cause:** A servo amplifier address was assigned two or more times in the control configuration.

**Solution:** Check control configuration. The duplicate address is shown in the control configuration in the parameter *DiagExtCode*. If the address is shown once, it is used twice; if it is shown twice, it is used three times, and so on.

#### 501 SERCOS client not found

- diagnosis class (default): 1
- quitable (default): yes (V00.15.00 or higher)

A servo amplifier entered in the control configuration cannot be found in the real-time bus.

**Cause:** Servo amplifier does not exist in SERCOS bus.

**Solution:** Integrate servo amplifier into SERCOS bus.

#### 502 loop not closed

- diagnosis class (default): 1
- quitable (default): no

The SERCOS loop is not closed.

See also bus err LED (SERCOS)

**Cause:** The SERCOS bus loop is not closed.

**Solution:** Close SERCOS loop.

#### 503 error in parameter channel

- diagnosis class (default): 4
- quitable (default): yes

A transmission error occurred in the real-time bus during operation. Additional information is recorded in *DiagExtCode*.

DiagExtCode	Meaning
ST-Err:xxx	service transfer error
ST-Timeout	timeout during service transfer
ST-Any	other service transfer error
ST-99	error when processing reset DC1
ST-99-ChangeBit	error when processing reset DC1; change bit was not set or protocol error
no SYNC	communication synchronization with slave is disturbed

Fig. 8-7: Meaning of DiagExtCodes

**Cause:** DiagExtCode = no SYNC

The loop contains SERCOS slaves (MC-4) with a firmware version less than V00.15.00 that are not addressed as real devices. This causes a serious error in the phase boot of the SERCOS bus and results in a termination of the phase boot.

**Solution:** For SERCOS slaves (MC-4) that have a firmware version less than V00.15.00 that and are not addressed as real devices, the SERCOS address must be set to 0.

**Cause:** EMC problem.

**Solution:** Check electric environment.

**Cause:** HW problem of a SERCOS slave (e.g. servo amplifier MC-4) or SERCOS master (e.g. PacDrive controller).

**Solution:** Contact our application department.

#### **504 read cycle overflow**

- diagnosis class (default): 4
- quitable (default): yes

The actual positions of the axes (servo amplifiers) were taken over into the PacDrive controller too late. The actual values of the next SERCOS cycle have already been read. The actual velocity (MC4.Velocity) may not be correct.

Note: The PacDrive controller / PacPC firmware does not use the actual velocity internally.

**Cause:** SERCOS bus overloaded.

**Solution:** Increase parameter CycleTime in control configuration.

**Cause:** One or several servo amplifiers were switched off and therefore no longer supply data on the SERCOS bus.

**Solution:** Switch on servo amplifiers.

#### **505 single SERCOS cycle error**

- diagnosis class (default): 6
- quitable (default): yes

A check sum error was detected on the SERCOS bus. The data (set and actual position) of the last cycle are reused.

See also bus err LED (SERCOS)

**Cause:** Signal via fiber-optic SERCOS cable not correct.

**Solution:** Check intensity setting in the PacDrive controller / PacPC and on the servo amplifier. Check fiber-optic cable.

**Cause:** EMC problems.

**Solution:** Check wiring.

### 506 multiple SERCOS cycle error

- diagnosis class (default): 1
- quittable (default): yes (V00.15.00 or higher)

A check sum error of the data on the SERCOS bus was detected in two consecutive cycles. The SERCOS bus was shut down. To restart it, the PacDrive controller / PacPC has to be reset.

**Cause:** DiagExtCode = RFr

The loop contains SERCOS slaves (MC-4) with a firmware version less than V00.15.00 that are not addressed as real devices. This causes a serious error in the phase boot of the SERCOS bus and results in a termination of the phase boot.

**Solution:** For SERCOS slaves (MC-4) that have a firmware version less than V00.15.00 that and are not addressed as real devices, the SERCOS address must be set to 0.

See also:

- 505 single SERCOS cycle error on page 94

### 507 write cycle overflow

- diagnosis class (default): 4
- quittable (default): yes

The set position was transmitted to the SERCOS bus too late. The last set positions may have been transmitted twice. This results in a velocity jump on the drives (see parameter RTPWriteRes).

See also bus err LED (SERCOS)

**Cause:** SERCOS bus overloaded.

**Solution:** Increase parameter CycleTime in control configuration.

**Cause:** Real-time bus overloaded.

**Solution:** Reduce the number of objects with real-time tasks (e.g. virtual axes, virtual encoders, logic encoders, sum encoders, ...)

**Cause:** One or several servo amplifiers were switched off and therefore no longer supply data on the SERCOS bus.

**Solution:** Switch on servo amplifiers.

### 508 SERCOS boot error

- diagnosis class (default): 1
- quittable (default): yes (V00.15.00 or higher)

A system error occurred.

**Cause:** Virtual SERCOS slaves have been entered in the control configuration, although the slaves are physically connected to the SERCOS bus.

**Solution:** Check control configuration.

**Cause:** The loop contains more SERCOS slaves than are entered in the control configuration.

**Solution:** Check control configuration.

### 509 FW version not supported

- diagnosis class (default): 4
- quittable (default): no

Firmware version of the servo amplifier is incorrect.

**Cause:** The firmware version of the SERCOS slave (MC-4, SCL, PS-4, ...) is higher than the firmware version of the PacDrive controller in the first 4 digits.

**Solution:** Update PacDrive controller firmware or install older SERCOS slave firmware.

### 510 no RTB interrupt

- diagnosis class (default): 4
- quittable (default): yes

The interrupt of the SERCOS bus has not arrived for at least double cycle time. This diagnosis message typically occurs in conjunction with other diagnosis messages (504 ... 507).

**Cause:** The problem occurs when the plant is switched off. The 24 V control voltage of the servo amplifiers is lifted faster than the 24 V control voltage of the PacDrive controller / PacPC.

**Solution:** Check wiring and wiring diagram.

**Cause:** Wiring error: The fiber-optic cable of the SERCOS bus is damaged.

**Solution:** Exchange fiber-optic cable.

**Cause:** A servo amplifier has failed.

**Solution:** Check servo amplifier.

### 511 CPU time overflow

- diagnosis class (default): 2
- quittable (default): no

Real-time bus overloaded (CycleLoad >95%). The measured load is shown in the parameter DiagExtCode with 'Load = xxx%', with xxx indicating the load in %.



### NOTE

Once the error has been detected, the actual and set values for encoders, generators and axes are no longer processed in the real-time process. Therefore the set and actual value parameters show no valid values.

---



**Cause:** Too many objects entered in the control configuration.

**Solution:** Increase the parameter `CylceTime` of the SERCOS bus in the control configuration.

### 512 SERCOS wrong device type

- diagnosis class (default): 1
- quitable (default): yes

During phase 2 of the SERCOS boot, the types of the detected SERCOS slave (MC-4, SCL, PS-4, ...) is checked against the one entered in the control configuration. If they do not match, the SERCOS phase boot is terminated. The SERCOS address and the detected type are recorded in the extended diagnosis.



### NOTE

There may also be an address multiplication, i.e. at least two SERCOS slaves have identical addresses.

See also:

- Diagnosis Group 5XX Real-Time Bus / Real-Time Process on page 93
- 517 multiple `RealTimeBusAdr` on page 97

**Cause:** The SERCOS address (`RealTimeBusAdr`) was not set correctly on the SERCOS slave (MC-4, SCL, PS-4, ...).

**Solution:** Check address setting on the SERCOS slave as shown in the diagnosis message. Check if the address setting on the SERCOS slave is the same as in the control configuration.

**Cause:** The SERCOS address (`RealTimeBusAdr`) was not entered correctly in the control configuration.

**Solution:** Check the parameter `RealTimeBusAdr` of the device shown in the diagnosis message.

### 513 download result

- diagnosis class (default): 4
- quitable (default): yes

### 514 error in download configuration file

- diagnosis class (default): 4
- quitable (default): yes

### 516 wrong device position

- diagnosis class (default): 1
- quitable (default): yes

### 517 multiple `RealTimeBusAdr`

- diagnosis class (default): 1
- quitable (default): yes

A SERCOS address (`RealTimeBusAdr`) was used more than once in the control configuration. This is checked when preparing

SERCOS phase 1. The SERCOS boot is terminated. The addresses are shown in the extended diagnosis.

**Cause:** A SERCOS address was used more than once in the control configuration.

**Solution:** Check control configuration. The address that was used more than once is shown in the control configuration in the parameter DiagExtCode and in the message logger under *Ext. diagnosis*.

### 518 too many real SERCOS slaves

- diagnosis class (default): 4
- quitable (default): yes

The number of real SERCOS slaves is too high.

**Cause:** **Ext. diagnosis: HW <number of licensed SERCOS slaves >/ <number of configures SERCOS slaves>**

Limitation by hardware configuration (licensing):

The number of real SERCOS slaves configured in the control configuration is checked before leaving SERCOS phase 0. Their number must be equal to or less than the number licensed for the PacDrive controller. If the number is exceeded, the boot is terminated. The licensed and configured numbers are shown with the prefix "HW" in the extended diagnosis.

**Solution:** Check the PacDrive controller type on the type plate.

**Cause:** **Ext. diagnosis: BUS t=<time overflow>µs**

The communication parameters of the SERCOS slaves are checked in SERCOS phase 2. Together with the SERCOS master, the time slots for cyclic telegram traffic are detected and set. The parameters BaudRate and CycleTime determine the available BUS bandwidth. If the bandwidth is not sufficient, the boot is terminated with diagnosis code 518 too many real SERCOS slaves. The time by which the cycle time was exceeded is shown as a negative value in the extended diagnosis.

**Cause:** The number of axes is too high for the cycle time.

**Solution:** Check CycleTime.

Check BaudRate.

## 8.3.6 Diagnosis Group 6XX Physical Master Encoder

### 600 serial interface problem

- diagnosis class (default): 4
- quitable (default): yes

No serial data could be received from the physical SinCos master encoder.

**Cause:** Wiring error: Encoder cable connected incorrectly or defective.

**Solution:** Check encoder cable and exchange, if necessary.

**Cause:** The functions PhyEncGetPosition(), PhyEncResetEncoder() and PhyEncSetPosition() exchange data via the serial encoder interface. The actual data exchange is done by the system task (TASK\_TYPE\_PHY\_ENC\_JOB\_Server). When the function is active, that task must scan the serial interface regularly (typically <2ms). Insufficient computing time may result in the loss of data (diagnosis message 600).

The system task TASK\_TYPE\_PHY\_ENC\_JOB\_Server runs with IEC priority 5 (equivalent to system priority 225). If the functions described above are called up with a priority of 1 to 4, this can cause problems in case of high computing needs.

**Solution:** Increase the priority of the system task.

**example** The function PhyEncGetPosition() is sent from an IEC task with IEC priority 4.. Typically the IEC task needs 2.5 ms for processing. The priority of the system task has to be increased from 255 (or IEC priority 5) to e.g. 224 (or IEC priority 4).

```
SetTaskPriority(ITaskType:=TASK_TYP_PHY_ENC_JOB_Server,
IPriority:=224);
```

**Cause:** Hardware error: SinCos encoder defective.

**Solution:** Exchange encoder.

**Cause:** Hardware error: SinCos encoder interface in the controller is defective.

**Solution:** Exchange controller.

### 601 trace error

- diagnosis class (default): 4
- quitable (default): yes

No analog data could be received from the physical SinCos master encoder.

**Cause:** Wiring error: Encoder cable connected incorrectly or defective.

**Solution:** Check encoder cable and exchange, if necessary.

**Cause:** Hardware error: SinCos encoder defective.

**Solution:** Exchange encoder.

**Cause:** Hardware error: SinCos encoder interface in the controller is defective.

**Solution:** Exchange controller.



## 9 Appendix

### 9.1 Contact

#### For repair

Please send the components to be repaired or checked, along with the error report, to this address:

#### ELAU AG

Abt. Kundendienst                      house address:  
Postfach 1255                              Dillberg 12  
97821 Marktheidenfeld                  97828 Marktheidenfeld  
Phone: +49 (0) 93 91 / 606-142  
Fax:     +49 (0) 93 91 / 606-340

#### Service team

Should you need to talk to a member of our service team or require on-site service, please contact:

#### ELAU AG

Dillberg 12  
D-97828 Marktheidenfeld  
Phone:     +49 (0) 9391 / 606 - 0  
Fax:        +49 (0) 9391 / 606 - 300  
e-mail:     info@elau.de  
Internet:   www.elau.de

#### ELAU, Inc.

165 E. Commerce Drive  
Schaumburg, IL 60173 - USA  
Phone:     +1 847 490 4270  
Fax:        +1 847 490 4206  
e-mail:     info@elau.com  
Internet:   www.elau.com

#### ELAU SYSTEMS ITALIA S.r.l.

Via Tosarelli 300  
I-40050 Villanova di Castenaso (BO)  
Phone:     +39 051 / 7818 70  
Fax:        +39 051 / 7818 69  
e-mail:     info@elau.it  
Internet:   www.elau.it



---

#### NOTE

Further contact addresses you can find on the ELAU homepage ([www.elau.de](http://www.elau.de)).

---

## 9.2 Further Literature

ELAU can provide you with these manuals and instructions on the PacDrive™ System:<sup>1</sup>

### **Project Manual**

Art.No. 17 13 00 58 - 00x (DE, EN, FR)

### **Programming Manual**

Art.No. 17 13 00 61 - 00x (DE, EN)

### **Operating Manual MC-4 MotorController**

Art.No. 17 13 00 62 - 00x (DE, EN, IT, FR)

### **Operating Manual CAN L2**

Art.No. 17 13 00 66 - 00x (DE, EN)

### **Operating Manual PROFIBUS-DP**

Art.No. 17 13 00 67 - 00x (DE, EN)

### **Operating Manual SM Motor**

Art.No. 17 13 00 68 - 00x (DE, EN, IT, FR)

### **Operating Manual EPAS-4**

Art.No. 17 13 00 70 - 00x (DE, EN)

### **Operating Manual PacDrive Controller MAX-4**

Art.No. 17 13 00 71 - 00x (DE, EN, IT, FR)

### **Operating Manual OPC-Server**

Art.No. 17 13 00 73 - 00x (DE, EN)

### **Operating Manual Device Net**

Art.No. 17 13 00 76 - 00x (DE, EN)

### **Operating Manual HMI Libraries**

Art.No. 17 13 00 77 - 00x (DE, EN)

### **Operating Manual INC-4 Incremental Encoder Module**

Art.No. 17 13 00 78 - 00x (DE, EN)

### **Operating Manual CANopen**

Art.No. 17 13 00 79 - 00x (DE, EN)

### **Operating Manual VarioCam® Editor ECAM-4**

Art.No. 17 13 00 80 - 00x (DE, EN)

### **Operating Manual PacNet Module PN-4**

Art.No. 17 13 00 81 - 00x (DE, EN)

### **Operating Manual SR Motor**

Art.No. 17 13 00 82 - 00x (DE, EN)

1. Art.No. -000 (DE) german -001 (EN) english -002 (IT) italian -003 (FR) french

**Operating Manual BusTerminal BT-4/DIO1**

Art.No. 17 13 00 83 - 00x (DE, EN)

**Operating Manual TTS**

Art.No. 17 13 00 88 - 00x (DE)

**User Manual Automatic Controller Optimization**

Art.No. 17 13 00 89 - 00x (DE, EN)

**Operating Manual PacDrive SCL**

Art.No. 17 13 00 93 - 00x (DE, EN)

**Operating Manual PacDrive PS-4 und PacDrive PD-8**

Art.No. 17 13 00 94 - 00x (DE, EN)

**Operating Manual Evaluation Kit**

Art.No. 17 13 00 95 - 00x (DE)

**Operating Manual PacDrive Controller P600**

Art.No. 17 13 00 96 - 00x (DE)

### 9.3 **Product Training**

We offer practical workshops and seminars.

Our experienced seminar leaders will enable you to make optimum use of the vast possibilities of the PacDrive™ system.



#### **NOTE**

Please contact us for further information or to order our seminar program. See also our homepage ([www.elau.de](http://www.elau.de)).

---

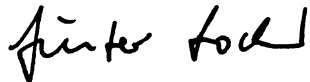

## 9.4 Declaration by the manufacturer

	<b>Herstellereklärung / Declaration by the manufacturer / Déclaration du fabricant</b>		<b>ELN 117-02/01.01</b>  Seite 1/1
<p>Produkt : <b>PacDrive Controller</b> <b>MAx-4 / 11</b></p> <p>Der Hersteller erklärt, dass das gelieferte Produkt in Übereinstimmung mit den angewendeten harmonisierten Normen / Spezifikationen hergestellt worden ist.</p> <p><b>Angewendete harmonisierte Normen:</b></p> <p><b>EN 60204-1 (11/1998)</b> Sicherheit von Maschinen - elektrische Ausrüstung</p> <p><b>EN 50081-2 (3/1994)</b> Fachgrundnorm für die Störaussendung</p> <p><b>EN 61000-6-2 (3/2000)</b> Fachgrundnorm Störfestigkeit</p> <p><b>Hersteller:</b> ELAU AG Dillberg 12 D-97828 Marktheidenfeld</p> <p><b>Stellung im Betrieb / Position :</b> Vorstand/Chairman</p> <p style="text-align: center;"></p> <p>9.1.2001 Günter Locherer ..... (Datum, Date / Unterschrift, Signature)</p>	<p>product: <b>PacDrive Controller</b> <b>MAx-4 / 11</b></p> <p>The manufacturer declares that the product delivered has been manufactured in accordance with the stated harmonized standards / specifications.</p> <p><b>Applied harmonized standards:</b></p> <p><b>EN 60204-1 (11/1998)</b> Safety of machines - electrical equipment</p> <p><b>EN 50081-2 (3/1994)</b> generic standard for noisy emission</p> <p><b>EN 61000-6-2 (3/2000)</b> generic standard interference-resistant</p> <p><b>Manufacturer:</b> ELAU AG Dillberg 12 D-97828 Marktheidenfeld</p>	<p>produit: <b>PacDrive Controller</b> <b>MAx-4 / 11</b></p> <p>Le fabricant déclare que le produit livré ont été fabriqués conformément a indiqués standards / spécifications harmonisés.</p> <p><b>Harmonisée standards appliqués:</b></p> <p><b>EN 60204-1 (11/1998)</b> Sécurité des machines-équipement électrique</p> <p><b>EN 50081-2 (3/1994)</b> norme générique pour l'émission brouillée</p> <p><b>EN 61000-6-2 (3/2000)</b> norme générique résistance au brouillage</p> <p><b>Fabricant:</b> ELAU AG Dillberg 12 D-97828 Marktheidenfeld</p>	

### **9.5 Safety Checks**

For the PacDrive Controller MAx-4 manufacturing the following security examinations are executed under EN 50178 / EN 60204-1:

**Check for continuous connection of the protective grounding system**

with 30 A

**Insulation resistance check**

with  $U = 500 \text{ V DC}$

**Tension strain check**

with  $U = 2500 \text{ V DC}$

for a time period of 1 min.

## 9.6 Modifications

---

### 01 / 1999

- Operating Manual newly written

### 07 / 1999

- Terms such as MAx-4, MC-4 and PacDrive™ M adjusted
- Electrical connections modified
- Sales regions updated

### 04 / 2000

- Structure of the document modified
- Updating

### 02 / 2001

- Designation of the inputs X3 and X4 updated
- various error corrections and supplements

### 04 / 2002

- Separate I/O supply new
- Chapter „Order Numbers“ was updated (BT-4/DIO1, PN-4, ...)
- Various error corrections and supplements

### 04 / 2004

- Various error corrections and supplements
- new chapter Diagnosis messages available



### NOTE

The latest documentation and modification service on this product are available on the ELAU Homepage ([www.elau.de](http://www.elau.de)).

---



## 9.7 Index

### A

approvals  
    MAx-4 44

### B

bus err 23

### C

commissioning 35  
configuration 36  
contact 101  
contents 3  
control voltage 22

### D

Diagnosis  
    example 25  
dimensions  
    MAx-4 55

### E

ELAU AG 2  
eMail  
    ELAU AG 2  
EMC rules 33  
err 22  
error indicator 22  
Ethernet connection 23  
Exchanging units 31

### F

file transfer 25

### H

homepage  
    ELAU AG 2

### I

I/Os 43  
Interfaces 41  
interference elimination 34  
internet  
    ELAU AG 2

### L

literature 102

### M

manuals 102  
message logger 21  
minimal boot 23  
minimal configuration 23  
modifications 107

### N

no connection 23

### O

operating manual 102  
operating system 41  
optional module 54  
order numbers 37  
    Accessories 40  
    Cables 39  
    MAx-4 37

### P

Packaging machine 15  
Performance 42  
PLS 42  
pow 22  
Power supply 44  
Processor 41  
Product configuration 41  
programming 36  
Programming languages 41  
Programming Manual 102

### R

repair 30, 101  
reset 21  
risk  
    classification 8

### S

safety notes 8  
seminare 104  
serial connection 23  
service  
    -personnel 101  
spare parts 29  
storage 27  
symbols, signs 6

system overview 15

**T**

trademarks 2

training 104

transportation 27

type plate 28

**U**

unpacking 27

Use as directed 9

**W**

Watchdog 22

## 9.8 Form for Error Report

This error report is absolutely necessary in order to enable efficient processing.

Send the error report to your ELAU representative or to:

ELAU AG, Abt. Kundendienst  
Dillberg 12, D-97828 Marktheidenfeld  
**Fax: +49 (0) 93 91 / 606 - 340**

Sender:

Company:	City:	Date:
Department:	Name:	Phone:

### Details on the defective product

Product name: .....

Article number: .....

Serial number: .....

Software version: .....

Hardware code: .....

Parameter enclosed:        yes [ ]    no [ ]

IEC program enclosed:     yes [ ]    no [ ]

### Details of the machine on which the problem occurred:

Machine producer: .....

Type: .....

Hours of operation: .....

Machine number: .....

Date of commissioning: .....

Producer/Type of machine control:

.....

