

# Operating Manual

## PacDrive™ SB Motor

Article Nr.: 17130052-100  
Edition: 2004-07



## Imprint

© All rights reserved to ELAU AG, also in case of patent right applications.

No part of this documentation and the related software and firm-ware may be reproduced, rewritten, stored on a retrieval system, transmitted or translated into any other language or computer language without the express written consent of ELAU AG.

Any possible measure was taken to ensure the that this product documentation is complete and correct. However, since hardware and software are continuously improved, ELAU makes no representations or warranties with respect to the contents of this product documentation.

## Trademarks

PacDrive is a registered trademark of ELAU AG.

All other trademarks mentioned are the exclusive property of their manufacturers.

ELAU AG  
Dillberg 12  
D-97828 Marktheidenfeld

Phone: +49 (0) 9391/606-0  
Fax: +49 (0) 9391/606-300

eMail: [info@elau.de](mailto:info@elau.de)  
Internet: [www.elau.de](http://www.elau.de)

ELAU Inc.  
4201 W. Wrightwood Ave.  
Chicago, IL 60639

Phone: 773 342 8400  
Fax: 773 342 8404

[sales@elau.com](mailto:sales@elau.com)  
[www.elau.com](http://www.elau.com)

# Contents

<b>1</b>	<b>Safety</b>	<b>5</b>
1.1	Depiction of Safety Notes .....	5
1.2	Use as Directed .....	6
1.3	Duties of the Machine Manufacturer .....	6
1.4	General Safety Instructions .....	7
1.5	Residual Risks .....	8
1.5.1	Installation and Handling .....	9
1.5.2	Protection against Touching Electrical Parts .....	9
1.5.3	"Safely Separated Low Voltages" .....	11
1.5.4	Potentially Dangerous Movements .....	11
<b>2</b>	<b>Use of This Operating Manual</b>	<b>13</b>
2.1	Target Group .....	13
2.2	Depiction Conventions .....	13
<b>3</b>	<b>Overview</b>	<b>15</b>
3.1	In General .....	15
3.2	Features of the servo motors .....	15
3.3	Versions .....	16
<b>4</b>	<b>Diagnosis</b>	<b>17</b>
<b>5</b>	<b>Transportation, Storage, Unpacking</b>	<b>19</b>
5.1	Transportation .....	19
5.2	Storage .....	19
5.3	Unpacking .....	20
<b>6</b>	<b>Maintenance</b>	<b>21</b>
6.1	Spare Parts, Components .....	21
6.2	Repair .....	22
6.3	Service Addresses .....	22
6.4	Exchanging Units .....	23
6.5	Cleaning .....	25
6.6	EMC Rules .....	25
6.7	Commissioning .....	28
6.8	Configuration / Programming .....	29
6.9	Order Numbers .....	30
6.9.1	SB Motor .....	30

6.9.2	Cable .....	45
<b>7</b>	<b>Technical Data</b>	<b>47</b>
7.1	General Technical Data .....	47
7.1.1	Definitions and Physical Correlations .....	47
7.1.2	Ambient conditions, approvals .....	52
7.1.3	Protection means .....	52
7.1.4	Motor shaft and bearing .....	53
7.1.5	Encoder .....	55
7.1.6	Holding brake (optional) .....	57
7.1.7	Surface ventilation (optional) .....	59
7.1.8	Technical Data in Detail .....	60
7.1.9	Torque-speed characteristics .....	72
7.2	Electrical Connections .....	100
7.3	Dimensions .....	103
7.3.1	SB-Motor .....	103
7.3.2	SP Gearbox .....	109
<b>8</b>	<b>Appendix</b>	<b>115</b>
8.1	Contact Addresses .....	115
8.2	Further Literature .....	116
8.3	Product Training .....	117
8.4	Declaration by the manufacturer .....	119
8.5	Modifications .....	120
8.6	Index .....	121
8.7	Form for Error Report .....	123

# 1 Safety

This chapter describes the general requirements for working safely. If the work involves any remaining risk, we will

- point this out in the respective passages,
- warn you of any possible danger and
- describe how the danger can be avoided.

## 1.1 Depiction of Safety Notes

### Risk categories

We differentiate between different categories of safety notes. The table below shows which danger and possible consequences the symbols (pictographs) and keywords point out.

Pictograph	Keyword	Definition
	<b>DANGER!</b>	Indicates an immediately dangerous situation that will result in death or very serious injuries if the safety rules are not observed.
	<b>WARNING!</b>	Indicates a possibly dangerous situation that can result in serious injuries or large material damage if the safety rules are not observed.
	<b>CAUTION!</b>	Indicates a possibly dangerous situation that might result in material damage if the safety rules are not observed.

### Notes

Information and notes are marked by a symbol (pictograph) and a keyword as well.

Pictograph	Keyword	Definition
	<b>NOTE</b>	Tips for usage and other important or useful information and notes

## 1.2 Use as Directed

The motors may only be used for the applications described in this manual and only in combination with third-party devices and components recommended or approved by ELAU.

Any other application is not regarded as "Use as directed".



---

### WARNING!

Risk of injury due to use other than directed!

If the motors are used in a different way than described above or modified without ELAU's approval, persons may be injured and material damage may occur.

---

"Use as directed" includes that you

- observe the Operating Manual and other documentations (see appendix),
- observe the instructions for inspection and maintenance.

## 1.3 Duties of the Machine Manufacturer



---

### NOTE

The machine manufacturer has to carry out a danger, error and risk analysis for the specific situation of this machine, and implement appropriate safety arrangements and safety measures in accordance with local safety regulations.

---

Safety is guaranteed if unpredicted movements from standstill and during controlled movement of the drive can be prevented.

The safety arrangements must be made in such a way that no dangerous situation can occur in case of an error.

Regarding the safety of people, this can be achieved by preventing people from entering or reaching into the danger zone while machinery is in operation (passive protection by means of blocked access, protective fences...).

The following norms, directives and regulations, among others, must be observed:

- DIN EN 60204 (11/1998) - machine safety: electric equipment of machines.

- DIN EN 292 sections 1 (11/1991) and 2 (6/1995) - machine safety: basics, general design rules.
- Universally valid rules for safety and accident prevention.
- Start-up operation is not allowed until it has been proved that the machine in which the products are installed complies with the rules of EC directive 89/392/EEC (machine directive).
- Operation is only permitted if the national EMT requirements for the respective application are fulfilled. In the EU, the valid EMT directive is 89/336/EEC.
- DIN EN 50178 (4/1998) - equipment of high-voltage systems with electronic operating means.

## 1.4 General Safety Instructions

In addition to this manual, please observe

- the prohibiting, warning and mandatory signs as well as the warnings on the components in the switching cabinet,
- the corresponding laws and regulations,
- the legal requirements concerning accident prevention,
- the operating instructions for the other components.

Always keep the operating manuals close to the machine.

### **The following safety instructions must be observed.**

- These safety instructions must be read and applied by all persons involved in the commissioning, operation, maintenance and repair of the machine.
- In addition to the notes in this manual, observe the universally valid local and national regulations for safety and accident prevention.
- Before doing any work on the equipment, the machine's power supply must be turned off and locked out.
- After installation, commissioning or maintenance work on the machine, the protection measures provided must be tested.
- Omit anything that might affect the safety of the machine.
- Unauthorized modification or manipulation of the equipment is prohibited for safety reasons.
- Those responsible for the safety of the plant must guarantee that
  - only qualified staff are entrusted with work on the appliances and machines
  - the operating manual is available at all times, and that the workers follow the manual's guidelines.
  - unqualified workers are forbidden to work on the equipment

and machines.

- For work on the equipment, observe the corresponding notes on the equipment (e.g. front side, casing).
- Flawless and safe operation of the product requires appropriate transport, storage, setup and installation as well as careful operation and maintenance.

## **1.5 Residual Risks**

---

The motors reflects the current technical standard .

Nevertheless, there is a residual risk, since the motors work with

- electrical current and voltage.

We minimized the health risk for people by means of appropriate construction and safety technology.



## 1.5.1 Installation and Handling

---



### **WARNING!**

Risk of injury while handling the unit!

Risk of injury due to squeezing, cutting or hitting!

- Observe the universally valid construction and safety rules for handling and installation.
  - Use suitable installation and transport facilities and use them professionally. If necessary, use special tools.
  - Take precautions against squeezing.
  - If necessary, use suitable protective clothing (e.g. safety glasses, safety shoes, protective gloves).
  - Do not stay under pending loads.
  - Remove any leaking liquids from the floor immediately to avoid skidding.
- 

## 1.5.2 Protection against Touching Electrical Parts

---

Touching parts carrying a voltage of 50 Volts or higher can be dangerous. When electric appliances are operated, certain parts of these appliances inevitably carry a dangerous voltage.



---

**DANGER!**

High voltage!

Life hazard!

- Observe the universally valid construction and safety rules for working on high-voltage units.
  - After installation, check the fixed connection of the earth conductor on all electric appliances according to the connection plan.
  - Operation, even for short-term measuring and test purposes, is only permitted with an earth conductor firmly connected to all electric components. Otherwise high voltages may occur on the casing.
  - Before accessing electrical parts with voltages exceeding 50 Volts, disconnect the unit from mains or power supply and lock it out. After switching off, wait for at least 5 minutes before touching any components.
  - Do not touch electrical connections of the components while the unit is on.
  - Before switching on the unit, cover all voltage carrying parts to prevent accidental contact.
  - Provide for protection against indirect touching (EN 50178 / 1998 section 5.3.2).
- 



---

**DANGER!**

High leak current!

Life hazard!

- Before switching on, first earth the electric equipment, each drive control and power supply unit and the motor or connect them to the central earthing point via a an earth conductor.
  - The leak current is greater than 3.5 mA. Therefore the units must have a firm connection to the power grid (according to DIN EN 50178 / 1998 - equipment of high-voltage systems).
  - Before initial operation, even for test purposes, always connect the earth conductor. Otherwise high voltage may occur on the casing.
-

### 1.5.3 "Safely Separated Low Voltages"

Signal voltage and control voltage of the PacDrive units are <33 Volts and must be arranged as safely separated low voltages. When installing other devices, electric components and cables, make sure that the existing safe separation is maintained throughout the power circuit.



---

**DANGER!**

High voltage due to wrong connection!

Life hazard or risk of serious injury!

- Only units, electric components or cables with a sufficient, safe separation of the connected power supplies according to EN 50178 / 1998 (equipment of high-voltage systems with electronic operating means) may be connected to the signal voltage connections of these components.
- 

### 1.5.4 Potentially Dangerous Movements

There can be different causes for potentially dangerous movements:

- mistakes in wiring or cable connection
- software errors
- faulty components
- errors in measuring value and signal encoders
- operating mistakes



---

**DANGER!**

Potentially dangerous movements!

Life hazard, serious injury or material damage!

- The monitoring functions in the driving components to a large extent rule out malfunction. For your protection, you must not rely on these functions alone. Until the controls installed become effective, you should anticipate faulty movement of the drive, which can vary depending on the kind of malfunction and the operating state. Personal protection must be ensured by additional measures superior to the plant. These are planned by the plant engineer with regard to the specific circumstances of the plant and after a risk and error analysis. The safety provisions of the plant are taken into account.
  - No persons are allowed within the motion range of the machine. This is to be ensured by means of devices like protective fences, grids, covers or photoelectric barriers.
  - The fences and covers must be sufficiently strong to withstand the maximum possible motion energy.
  - The emergency stop switch must be located very close to the operator. Check the operation of the emergency stop before starting up the plant.
  - Secure against unintentional start by enabling the mains contactor of the drives via an emergency off circuit or by means of the function 'safe stop'.
  - Before accessing the danger zone, bring the drives to a safe stop.
  - To work on the plant, power must be turned off and locked out.
  - Avoid operating high-frequency, remote-control and radio devices in the vicinity of the plant's electronics and connecting wires. If the use of those devices is inevitable, check system and plant for possible malfunctions before first operation. In some cases a special EMT check may be necessary.
-

## 2 Use of This Operating Manual

### 2.1 Target Group

This operating manual is aimed exclusively at technically qualified staff with detailed knowledge in the field of automation technology.

Only qualified staff can understand the significance of the safety notes and act accordingly.

This operating manual is aimed primarily at design and application engineers specializing in mechanical and electrical engineering, at programmers, service and commissioning engineers.



#### NOTE

Should you not be able to solve problems with the help of this manual, please contact

ELAU AG  
 - Abteilung Kundendienst -  
 Postfach 1255  
 D-97821 Marktheidenfeld  
 Telefon: 09391/606-142  
 Fax: 09391/606-300

### 2.2 Depiction Conventions

Symbol	Meaning
■	Marks the first level of an enumeration.
–	Marks the second level of an enumeration.
➤	Marks instructions for an action.
normal	Normal text.
<i>italics</i>	Marks a special term (e.g. parameter).
Code	Program code

Table 2-1: Depiction conventions



## 3 Overview

---

### 3.1 In General

---

The highly dynamic synchronous AC servo motors of ELAU's SB series are permanently excited synchronous machines designed especially for highly dynamic positioning tasks.

The low moment of inertia compared with other AC servo motors in combination with the high overload tolerance not only guarantees excellent acceleration values, but also reduces energy consumption and stray heat of the motor.

The torque is generated by the stator coil fed by a sinusoidal three-phase current system in combination with the magnetic field excited by the rotor magnets.

The generation of the rotary current system depends on the rotor position in the digital motor controller or the positioning motor controller.

For that purpose, the rotor position is monitored by a resolver. Thanks to that principle, the drives are extremely robust and work without wearing down.

### 3.2 Features of the servo motors

---

The SB motors are characterised by the following features:

- High reliability of maintenance-free
- Maintenance-free operation
- Overload protection (by motor temperature monitoring)
- High performance data
- High dynamics
- High overload capacity
- Large torque area
- sinusoidal EMK
- High volt technique = low currents
- Low mass-moment of inertia
- Motor link and feedback system over connection box
- Simple and fast commissioning (by electronic vehicle identification plate in the SinCos encoder)

### 3.3 Versions

#### Motor feedback

- SinCos encoder singleturn or
- SinCos encoder multiturn or
- Resolver feedback

#### Holding brake

- without brake (standard) or
- with brake (option) to hold the axis without ply in standstill or while the plant is powerless.

#### Shaft

- Smooth shaft (standard) or
- Shaft with feather groove (option)

#### Miscellaneous

- The SB motors also with ventilator or gear suppliable.



## **4** **Diagnosis**

---

The error diagnosis and monitoring of the operating conditions is executed into the ELAU controllers. See for this the appropriate descriptions.



## 5 **Transportation, Storage, Unpacking**

### 5.1 **Transportation**

- Avoid shocks.
- Immediately check units for transport damage and inform your transport company, if necessary.

### 5.2 **Storage**

- Store units in a clean, dry place.

**Storage conditions:**

- air temperature between - 25 °C and + 70 °C.
- temperature fluctuations max. 30 K per hour.

### 5.3 Unpacking

- Check whether the delivery is complete.
- Check all units for transport damage.

#### Type plate

The type plate contains all necessary information:



type plate

CE identification

QC passed

Fig. 5-1: type plate at the SB motor



Fig. 5-2: type plate of a SB motors

## 6 Maintenance

---

Recognizing and clearing an error quickly helps to keep the related production loss down to a minimum.

The diagnosis messages of the PacDrive™ system, which can be checked using EPAS, make it possible to look for errors deliberately and effectively.

In case of an error, defective components can be exchanged with no problem. This ensures that the problem can be solved quickly and operation can be resumed soon. This work must be done by qualified maintenance staff only.

When returning a defective unit to the ELAU customer service, please complete the attached error report form.

### 6.1 Spare Parts, Components

---

#### Stock keeping of spare parts:

Keeping a stock of the essential components is a key prerequisite for the permanent functionality of the equipment.



---

#### ATTENTION!

Device compatibility!

Only units with identical hardware configuration and identical software version may be exchanged.

---

#### When ordering spare parts, please give the following data:

product name: e. g. SB 105/30/04/05/19/S/R1/64/EAKN

article number: e. g. 19192304-008



---

#### NOTE

You can find this information on the type plate of the equipment (see Bild 5-1) or in the configuration of your PacDrive™ M system.

---

## 6.2 Repair

By all means complete the attached error report form when returning defective components.

You can also make a photocopy of the error report form and use it as a fax message.



### ATTENTION!

Electro static discharge!

Components may be damaged!

- Electronic parts may only be returned in the original or a comparable packaging. In any case the components must be wrapped in an ESD packaging/foil. Otherwise you will lose your warranty rights.

## 6.3 Service Addresses

### For ordering spare parts

ELAU AG  
 Postfach 1255  
 97821 Marktheidenfeld  
 Phone: +49 (0) 93 91 / 606 - 0  
 Fax: +49 (0) 93 91 / 606 - 300

### For repair

Please send the components to be repaired or checked, along with the error report, to this address:

ELAU AG	
Abt. Kundendienst	
postal address:	house address:
Postfach 1255	Dillberg 12
97821 Marktheidenfeld	97828 Marktheidenfeld

### Service team

Should you need to talk to a member of our service team or require on-site service, please contact:

ELAU AG  
 Abt. Kundendienst / Applikation  
 Postfach 1255  
 97821 Marktheidenfeld  
 Phone: +49 (0) 93 91 / 606 - 142  
 Fax: +49 (0) 93 91 / 606 - 300

## 6.4 Exchanging Units

---



### **DANGER!**

High Voltage!

Life Hazard!

- Before working on electrical units, disconnect from mains supply and secure against switch-on.
  - The drives must be standing safely because life-threatening voltages can occur on the motor cables of servo motors in generator operation.
  - Do not disconnect connector plugs while they are carrying voltage.
- 



### **CAUTION!**

Electro static discharge!

Components may be damaged!

- Only touch the boards on the edges. Do not touch any connections or components.
  - Before touching the boards, discharge any possible static charge. For this purpose, touch an earthed metal surface, e.g. the casing.
  - Do not place the boards on a metal surface.
  - Move the boards as little as possible to avoid the creation of electro static charge due to clothing, carpets or furniture.
- 

### **Exchange motor**



### **NOTE**

If motors were stored longer than 2 years, the holding brake has to be grind in before you use him. See also " holding brake (option)" on page 53.

---

- lift the main switch
- secure against switch-on



---

**DANGER!**

High voltage!

Life hazard!

- Performance plug connectors of the cables only in status without tension of the system separate or join!
- 



---

**WARNING!**

Inadvertent oh movements!

Danger of accident!

- With servo axles with indirect distance measurement system over the motor encoder the measure reference is lost with exchange of the engine!  
The measure reference to the machine coordinate system is to be reconstituted therefore after the exchange again!
  - With exchange of an motor the specification of the machine manufacturer is to be considered.
  - During indirect entry of the position actual values over the motor-own measuring system the measure reference must again be reconstituted.
- 



---

**CAUTION!**

Mechanical force!

Damage of the encoder system is possible!

- When removing and applying of clutches on the motor shaft no impact may be executed on the motor shaft, since otherwise the encoder is damaged. Use suitable tools e. g. pullers.
- 

**Exchange cable**

- lift the main switch
- secure against switch-on





**DANGER!**

High voltage!

Life hazard!

- Performance plug connectors of the cables only in status without tension of the system separate or join!
- Performance plug connectors only with dry and clean putting pages join!
- If no finished manufactured cables are used by ELAU, allocation of new cables for agreement with the connection diagram of the machine manufacturer to check!

- With exchange of cables the specification of the machine manufacturer is to be considered.

## 6.5 Cleaning

With suitable installation the devices are to a large extend maintenance-free.



**CAUTION!**

Penetrating liquid by inappropriate cleaning!

Damage to the motor!

- During the cleaning of the engine with high pressure cleaner liquid can penetrate in the crankshaft housing. Use cleaning methods according to the enclosure of the engine.

## 6.6 EMC Rules

To control and regulate motors, the mains voltage is stored in the DC-circuit of the MC-4 MotorController by means of rectification. This stored energy is fed to the motor by deliberately switching on and off six semiconductor switches. The steep rise and fall of the voltage puts high demands on the insulation strength of the motor winding. Another essential aspect to be considered is the Electro Magnetic Compatibility (EMC) with other system components. The flank steepness of the clocked voltage generates harmonic oscillations of great intensity, up into the high-frequency range.

**Therefore observe the following EMC rules:**

- Choose the earthing option with the lowest possible ohm rate (e.g. unpainted mounting board of the switching cabinet) for installation.
- Contact the largest possible surface (skin effect). If necessary, remove existing paint to achieve large-surface contact.
- From the Central Earthing Point (CEP), lay earthing wires to the respective connections in a star structure. Earthing circuits are not admissible and can cause unnecessary distortions.
- Use shielded cables only.
- Only large-surface shield transitions are admissible.
- Shields must not be contacted via pin contacts of connector plugs.
- By all means observe the switching proposals.
- Cut motor cables to minimum length.
- Do not lay cable circuits inside the switching cabinet.



**CAUTION!**

Electromagnetic fields!

Disturbances or failure of the system possible!

- With the installation the following rules must be considered, in order to exclude consequences of excessive disturbance effects as far as possible.

- In connection with electronic controls, no inductive loads whatsoever must be switched without suitable interference elimination.
- For DC operation, suitable interference elimination can be achieved by arranging recovery diodes. For AC operation, commercially available erasing elements matching the connector type can be used.
- Only the interference elimination element mounted immediately at the point of inductivity serves this purpose. In any other case, the switching pulse may even emit increased interference via the interference elimination elements. It is much easier to avoid sources of interference in the first place, than to eliminate the effects of existing interference.
- In no case must the contacts switching unshielded inductive loads be arranged in the same room as the MC-4 MotorController; the same goes for cables carrying unshielded, switched inductivity and cables running parallel to them. The control must be separated from such „distorters“ by a Faraday cage (own section in the switching cabinet).



---

**CAUTION!**

Electromagnetic fields!

Disturbances or failure of the system possible!

- Dependent on the combination MotorController / Motor and the cable length are to be used possibly system filters or motor filters. Consider for this the projecting manuals of the MotorControllers (MC-4 / PMC-2).
-

## 6.7 Commissioning

We recommend to take up with the first commissioning ELAU personnel.

This should not only occur for guarantee reasons, but

- the equipment checked,
- which determines optimal configuration,
- the service personnel is instructed at the same time.

### Procedure

<b>Unpacking and checking the devices</b>	After removing the packing you check please the devices for soundness. Only intact devices may be put into operation. Check please additionally the supply for completeness. Compare the data on the basis the identification plates.	see „Transportation, Storage, Unpacking”
<b>Installation</b>	Install afterwards the devices considering of the request to the setting up place, the enclosure and the EMC rules	see „Maintenance”
<b>Devices electrically attach</b>	Attach they now the devices, beginning with protective grounding. Make sure they that all clamps are fixed tightened, which are used necessary cable diameters the screen were correctly executed and no interruptions and short-circuits to be present.	see „Technical Data” and „Maintenance”
<b>Examination of the safety functions</b>	<ul style="list-style-type: none"> <li>- To motor thermojunction or PTC.</li> <li>- Functions the brake, if available?</li> <li>- Does the emergency stop chain function?</li> <li>- Do the emergency stop limit switches function?</li> </ul>	
<b>further commissioning according to the concrete system</b>	See operating instruction of the packaging machine manufacturer and the MotorControllers.	

Table 6-1: Procedure of the first commissioning

## 6.8 Configuration / Programming

The motors are adjusted with ELAU. The customer does not have to execute alignment.

The adjustment of the MotorControllers to the motors is to be inferred from the documentation of the respective MotorController.

See also the documentation of the MotorController.

## 6.9 Order Numbers

### 6.9.1 SB Motor

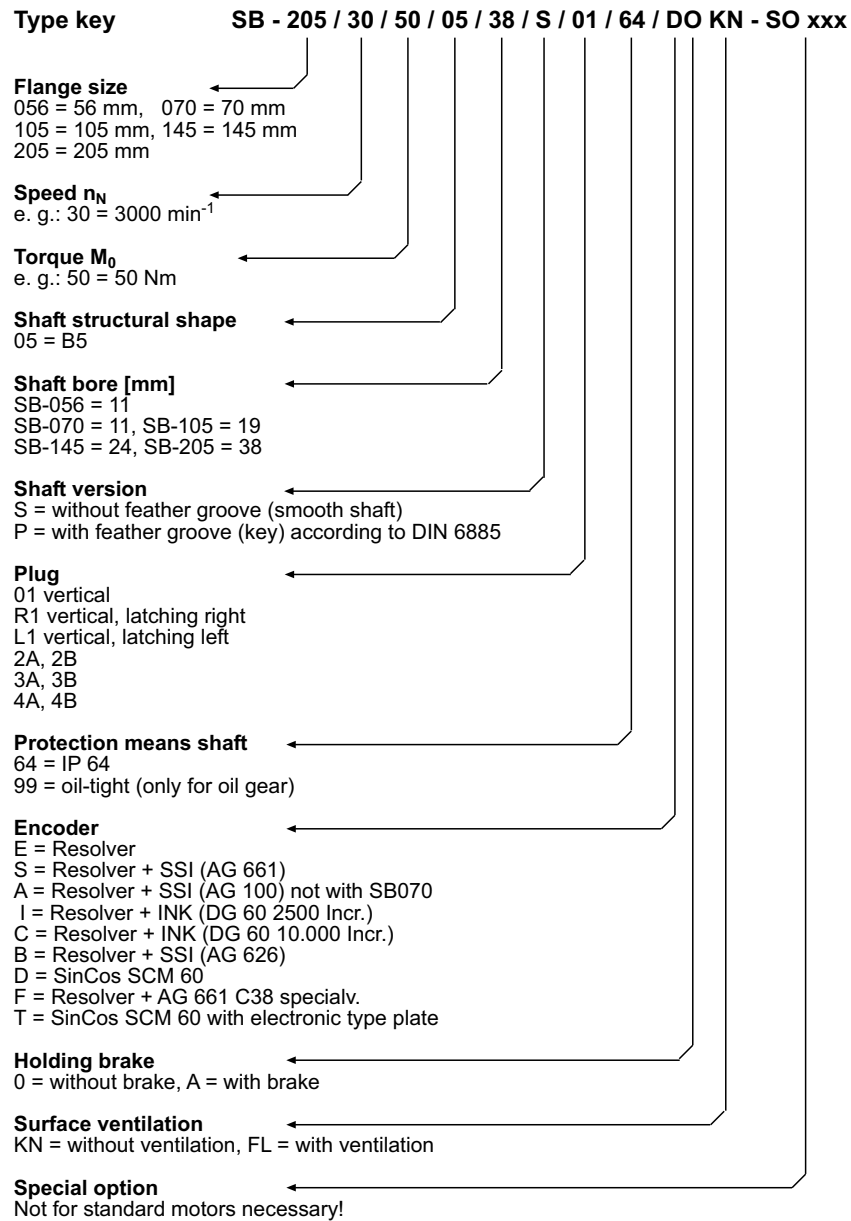

Fig. 6-1: Type key legend for SB Motor

Order number	Product name	Explanations
19191405	<b>SB070 40 05 XX 0.5 Nm 4000 min<sup>-1</sup></b>	
19191405-001	SB070/40/05/05/11P/01/64/SOKN	
19191405-002	SB070/40/05/05/11/P/2A/64/EOKN	
19191405-003	SB070/40/05/05/11/S/01/64/EOKN	
19191405-005	SB070/40/05/05/11/S/R1/64/EOKN	
19191405-006	SB070/40/05/05/11/P/01/64/EOKN	
19191405-007	SB070/40/05/05/11/S/R1/64/EAKN	
19191405-008	SB070/40/05/05/11/P/01/64/EOKN	
19191405-009	SB070/40/05/05/11/S/01/64/IOKN	
19191405-010	SB070/40/05/05/11/P/3B/64/EAKN	
19191405-011	SB070/40/05/05/11/P/01/64/EAKN	
19191405-012	SB070/40/05/05/11/S/01/64/EAKN	
19191405-013	SB070/40/05/05/11/P/3A/64/EOKN	
19191405-014	SB070/40/05/05/11/S/01/64/BAKN	
19191410	<b>SB070 40 10 XX 1.0 Nm 4000 min<sup>-1</sup></b>	
19191410-001	SB070/40/10/05/11/S/01/64/EOKN	
19191410-002	SB070/40/10/05/11/P/2A/64/EOKN	
19191410-003	SB070/40/10/05/11/P/SO/64/EAKN	
19191410-004	reserviert	
19191410-005	SB070/40/10/05/11/P/01/64/EOKN	
19191410-006	SB070/40/10/05/11/S/01/64/EAKN	
19191410-007	SB070/40/10/05/11/S/R1/64/EOKN	
19191410-008	SB070/40/10/05/11/S/R1/64/EAKN	
19191410-009	SB070/40/10/05/11/S/2A/64/EOKN	
19191410-010	SB070/40/10/05/11/P/01/64/EAKN	
19191410-011	SB070/40/10/05/11/S/01/64/BAKN	
19191410-012	SB070/40/10/05/11/P/3A/64/EAKN	
19191410-013	SB070/40/10/05/11/P/3B/64/EOKN	
19191410-015	SB070/40/10/05/11/P/3B/64/EAKN	
19191410-016	SB070/40/10/05/11/S/3A/64/EOKN	

Order number	Product name	Explanations
19191410-017	SB070/40/10/05/11/S/3B/64/EOKN	
19191415	<b>SB070 40 15 XX 1.5 Nm 4000 min<sup>-1</sup></b>	
19191415-001	SB070/40/15/05/11/P/01/64/EOKN	
19191415-002	SB070/40/15/05/11/P/2A/64/EAKN	
19191415-003	SB070/40/15/05/11/S/01/64/EOKN	
19191415-004	SB070/40/15/05/11/P/01/64/BAKN	
19191415-005	SB070/40/15/05/11/S/01/64/BAKN	
19191415-006	SB070/40/15/05/11/S/R1/64/EOKN	
19191415-007	SB070/40/15/05/11/P/01/64/EAKN	
19191415-008	SB070/40/15/05/11/P/R1/64/EOKN	
19191415-009	SB070/40/15/05/11/S/01/64/EAKN	
19191420	<b>SB070 40 20 XX 2.0 Nm 4000 min<sup>-1</sup></b>	
19191420-001	SB070/40/20/05/11/P/01/64/EOKN	
19191420-002	SB070/40/20/05/11/P/2A/64/EOKN	
19191420-003	SB070/40/20/05/11/S/01/64/EAKN	
19191420-004	SB070/40/20/05/11/S/01/64/EOKN	
19191420-005	SB070/40/20/05/11/P/2A/64/EAKN	
19191420-006	SB070/40/20/05/11/S/2A/64/EOKN	
19191420-007	SB070/40/20/05/11/S/3B/64/SAKN	
19191420-008	SB070/40/20/05/11/S/3B/64/EAKN	
19191420-009	SB070/40/20/05/11/S/01/64/DOKN	
19191420-010	SB070/40/20/05/11/P/01/64/EOFL	
19191420-011	SB070/40/20/05/11/S/2B/64/EOKN	
19191420-012	SB070/40/20/05/11/S/R1/64/EAKN	
19191420-013	SB070/40/20/05/11/S/01/64/EOFL	
19191420-014	SB070/40/20/05/11/P/01/64/EAKN	
19191605	<b>SB070 60 05 XX 0.5 Nm 6000 min<sup>-1</sup></b>	
19191605-001	SB070/60/05/05/11/S/01/64/EOKN	
19191605-002	SB070/60/05/05/11/P/01/64/EAKN	



Order number	Product name	Explanations
19191610	<b>SB070 60 10 XX 1.0 Nm 6000 min<sup>-1</sup></b>	
19191610-001	SB070/60/10/05/11/S/01/64/EOKN	
19191610-002	SB070/60/10/05/11/P/01/64/EOKN	
19191610-003	SB070/60/10/05/11/P/01/64/EAKN	
19191610-004	SB070/60/10/05/11/S/01/64/EAKN	
19191615	<b>SB070 60 15 XX 1.5 Nm 6000 min<sup>-1</sup></b>	
19191615-001	SB070/60/15/05/11/S/01/64/EOKN	
19191615-002	SB070/60/15/05/11/P/01/64/EOKN	
19191620	<b>SB070 60 20 XX 2.0 Nm 6000 min<sup>-1</sup></b>	
19191620-001	SB070/60/20/05/11/P/01/64/EAKN	
19191620-002	SB070/60/20/05/11/S/01/64/EOKN	
19191620-003	SB070/60/20/05/11/S/01/64/EAKN	
19191620-004	SB070/60/20/05/11/P/01/64/EOKN	
19192202	<b>SB105 20 02 XX 2 Nm 2000 min<sup>-1</sup></b>	
19192202-001	SB105/20/02/05/19/P/01/64/EOKN	
19192202-002	SB105/20/02/05/19/P/01/64/BOKN	
19192202-003	SB105/20/02/05/19/P/01/64/DOKN	
19192202-004	SB105/20/02/05/19/P/01/64/BAKN	
19192202-005	SB105/20/02/05/19/S/01/64/EOKN	
19192204	<b>SB105 20 04 XX 4 Nm 2000 min<sup>-1</sup></b>	
19192204-001	SB105/20/04/05/19/P/01/64/EAKN	
19192204-002	SB105/20/04/05/19/P/01/64/EOKN	
19192204-003	SB105/20/04/05/19/P/01/64/BAKN	
19192204-004	SB105/20/04/05/19/S/01/64/DAKN	
19192204-005	SB105/20/04/05/19/S/01/64/EOKN	
19192206	<b>SB105 20 06 XX 6 Nm 2000 min<sup>-1</sup></b>	

Order number	Product name	Explanations
19192206-001	SB105/20/06/05/19/S/01/64/EOKN	
19192206-002	SB105/20/06/05/19/S/01/64/EAKN	
19192208	<b>SB105 20 08 XX 8 Nm 2000 min<sup>-1</sup></b>	
19192208-001	SB105/20/08/05/19/P/01/64/EOKN	
19192208-002	SB105/20/08/05/19/S/01/64/EOKN	
19192208-003	SB105/20/08/05/19/S/01/64/EAKN	
19192208-004	SB105/20/08/05/19/S/01/64/EAFL	
19192208-005	SB105/20/08/05/19/S/01/64/DAFL	
19192302	<b>SB105 30 02 XX 2 Nm 3000 min<sup>-1</sup></b>	
19192302-001	SB105/30/02/05/19/S/01/64/EOKN	
19192302-002	SB105/30/02/05/19/S/2B/64/EOKN	
19192302-003	SB105/30/02/05/19/P/01/64/EOKN	
19192302-004	SB105/30/02/05/19/P/2B/64/EOKN	
19192302-005	SB105/30/02/05/19/P/01/64/EAKN	
19192302-006	SB105/30/02/05/19/S/01/64/EAKN	
19192302-007	SB105/30/02/05/19/P/01/64/SOKN	
19192302-008	SB105/30/02/05/19/P/2A/64/EOKN	
19192302-009	SB105/30/02/05/19/P/01/64/AAKN	
19192302-010	SB105/30/02/05/19/P/3A/64/EAKN	
19192302-011	SB105/30/02/05/19/S/2A/64/EOKN	
19192302-012	SB105/30/02/05/19/S/R1/64/EAKN	
19192302-013	SB105/30/02/05/19/P/01/64/BAKN	
19192302-015	SB105/30/02/05/19/S/01/64/DOKN	
19192302-016	SB105/30/02/05/19/S/01/64/BOKN	
19192302-017	SB105/30/02/05/19/S/R1/64/BAKN	
19192302-018	SB105/30/02/05/19/S/01/64/DAKN	
19192302-019	SB105/30/02/05/19/P/01/64/DAKN	
19192304	<b>SB105 30 04 XX 4 Nm 3000 min<sup>-1</sup></b>	
19192304-001	SB105/30/04/05/19/P/2B/64/EOKN	

Order number	Product name	Explanations
19192304-002	SB105/30/04/05/19/S/2B/64/EAKN	
19192304-003	SB105/30/04/05/19/S/01/64/SOKN	
19192304-004	SB105/30/04/05/19/S/01/64/EAKN	
19192304-005	SB105/30/04/05/19/P/01/64/EOKN	
19192304-006	SB105/30/04/05/19/S/01/64/EOKN	
19192304-007	SB105/30/04/05/19/S/R1/64/EOKN	
19192304-008	SB105/30/04/05/19/S/R1/64/EAKN	
19192304-009	SB105/30/04/05/19/S/2A/64/EOKN	
19192304-010	SB105/30/04/05/19/P/01/64/EAKN	
19192304-011	SB105/30/04/05/19/P/01/64/BAKN	
19192304-012	SB105/30/04/05/19/S/2A/64/SOKN	
19192304-013	SB105/30/04/05/19/S/01/64/BAKN	
19192304-014	SB105/30/04/05/19/S/01/64/DAKN	
19192304-015	SB105/30/04/05/19/P/01/64/DAKN	
19192304-016	SB105/30/04/05/19/S/R1/64/DOKN	
19192304-017	SB105/30/04/05/19/P/R1/64/DOKN	
19192304-018	SB105/30/04/05/19/P/2A/64/EOKN	
19192304-021	SB105/30/04/05/19/S/3A/64/DAKN	
19192304-022	SB105/30/04/05/19/S/3A/64/EAKN	
19192306	<b>SB105 30 06 XX 6 Nm 3000 min<sup>-1</sup></b>	
19192306-001	SB105/30/06/05/19/S/01/64/EOKN	
19192306-003	SB105/30/06/05/19/P/01/64/EOKN	
19192306-004	SB105/30/06/05/19/S/01/64/EAKN	
19192306-005	SB105/30/06/05/19/P/2A/64/EOKN	
19192306-006	SB105/30/06/05/19/P/01/64/SOKN	
19192306-007	SB105/30/06/05/19/S/2A/64/EOKN	
19192306-008	SB105/30/06/05/19/P/01/64/EAKN	
19192306-009	SB105/30/06/05/19/S/3A/64/EAKN	
19192306-010	SB105/30/06/05/19/S/3B/64/EAKN	
19192306-011	SB105/30/06/05/19/S/R1/64/EAKN	
19192306-012	SB105/30/06/05/19/P/3A/64/EAKN	

Order number	Product name	Explanations
19192306-013	SB105/30/06/05/19/P/R1/64/IAKN	
19192306-014	SB105/30/06/05/19/S/01/64/DAKN	
19192306-015	SB105/30/06/05/19/P/01/64/DAKN	
19192306-016	SB105/30/06/05/19/S/R1/64/EOKN	
19192306-017	SB105/30/06/05/19/S/01/64/DOKN	
19192306-018	SB105/30/06/05/19/S/01/64/BOKN	
19192306-019	SB105/30/06/05/19/S/01/64/BAKN	
19192308	<b>SB105 30 08 XX 8 Nm 3000 min<sup>-1</sup></b>	
19192308-001	SB105/30/08/05/19/P/2B/64/EOKN	
19192308-002	SB105/30/08/05/19/S/2B/64/EOKN	
19192308-003	SB105/30/08/05/19/S/01/64/EOKN	
19192308-004	SB105/30/08/05/19/P/2A/64/EOKN	
19192308-005	SB105/30/08/05/19/P/01/64/EOKN	
19192308-006	SB105/30/08/05/19/S/01/64/SOKN	
19192308-007	SB105/30/08/05/19/P/01/64/EAKN	
19192308-008	SB105/30/08/05/19/S/01/64/EAKN	
19192308-009	SB105/30/08/05/19/S/01/64/BAKN	
19192308-010	SB105/30/08/05/19/P/01/64/BAKN	
19192308-011	SB105/30/08/05/19/S/2A/64/EOKN	
19192308-012	SB105/30/08/05/19/S/01/64/BOKN	
19192308-013	SB105/30/08/05/19/S/01/64/DAKN	
19192308-014	SB105/30/08/05/19/S/01/64/DOKN	
19192308-015	SB105/30/08/05/19/S/01/64/EOFL	
19192308-016	SB105/30/08/05/19/P/01/64/EOFL	
19192308-017	SB105/30/08/05/19/P/01/64/DAKN	
19192308-018	SB105/30/08/05/19/S/3A/64/EAKN	
19192402	<b>SB105 40 02 XX 2 Nm 4000 min<sup>-1</sup></b>	
19192402-001	SB105/40/02/05/19/P/01/64/EOKN	
19192402-002	SB105/40/02/05/19/P/3A/64/EAKN	
19192402-003	SB105/40/02/05/19/S/R1/64/EOKN	

Order number	Product name	Explanations
19192402-004	SB105/40/02/05/19/S/R1/64/EAKN	
19192402-005	SB105/40/02/05/19/P/R1/64/EOKN	
19192402-006	SB105/40/02/05/19/S/01/64/DAKN	
19192402-007	SB105/40/02/05/19/P/R1/64/EAKN	
19192402-008	SB105/40/02/05/19/P/01/64/DOKN	
19192402-009	SB105/40/02/05/19/P/01/64/EAKN	
19192402-010	SB105/40/02/05/19/P/01/64/DAKN	
19192404	<b>SB105 40 04 XX 4 Nm 4000 min<sup>-1</sup></b>	
19192404-001	SB105/40/04/05/19/S/2A/64/EOKN	
19192404-002	SB105/40/04/05/19/S/R1/64/EAKN	
19192404-003	SB105/40/04/05/19/P/01/64/EAKN	
19192404-004	SB105/40/04/05/19/S/01/64/EOKN	
19192404-005	SB105/40/04/05/19/P/01/64/EOKN	
19192404-006	SB105/40/04/05/19/S/R1/64/EOKN	
19192404-007	SB105/40/04/05/19/P/01/64/DOKN	
19192404-008	SB105/40/04/05/19/P/01/64/DAKN	
19192404-009	SB105/40/04/05/19/S/01/64/DAKN	
19192404-010	SB105/40/04/05/19/S/01/64/EOFL	
19192406	<b>SB105 40 06 XX 6 Nm 4000 min<sup>-1</sup></b>	
19192406-001	SB105/40/06/05/19/S/01/64/EOKN	
19192406-002	SB105/40/06/05/19/S/01/64/EAKN	
19192406-003	SB105/40/06/05/19/S/2A/64/EOKN	
19192406-004	SB105/40/06/05/19/P/01/64/EOKN	
19192406-005	SB105/40/06/05/19/P/01/64/EAKN	
19192406-006	SB105/40/06/05/19/P/01/64/DAKN	
19192408	<b>SB105 40 08 XX 8 Nm 4000 min<sup>-1</sup></b>	
19192408-001	SB105/40/08/05/19/S/01/64/EAKN	
19192408-002	SB105/40/08/05/19/P/01/64/EOKN	
19192408-003	SB105/40/08/05/19/S/01/64/EOKN	

Order number	Product name	Explanations
19192408-004	SB105/40/08/05/19/S/01/64/EAFI	
19192408-005	SB105/40/08/05/19/S/01/64/EOFL	
19192408-006	SB105/40/08/05/19/P/01/64/DAKN	
19192408-007	SB105/40/08/05/19/P/01/64/EAKN	
19192408-008	SB105/40/08/05/19/S/01/64/DAKN	
19192408-009	SB105/40/08/05/19/S/2A/64/EOKN	
19193208	<b>SB145 20 08 XX 8 Nm 2000 min<sup>-1</sup></b>	
19193208-001	SB145/20/08/05/24/S/R1/64/EAKN	
19193208-002	SB145/20/08/05/24/S/01/64/EOKN	
19193208-003	SB145/20/08/05/24/P/01/64/EOKN	
19193208-004	SB145/20/08/05/24/S/01/64/DAKN	
19193215	<b>SB145 20 15 XX 15 Nm 2000 min<sup>-1</sup></b>	
19193215-001	SB145/20/15/05/24/S/01/64/EOKN	
19193215-002	SB145/20/15/05/24/P/01/64/EAKN	
19193215-003	SB145/20/15/05/24/P/01/64/EOKN	
19193215-004	SB145/20/15/05/24/S/01/64/EAKN	
19193215-005	SB145/20/15/05/24/S/01/64/DAKN	
19193222	<b>SB145 20 22 XX 22 Nm 2000 min<sup>-1</sup></b>	
19193222-001	SB145/20/22/05/24/P/2B/64/EOKN	
19193222-002	SB145/20/22/05/24/P/01/64/COKN	
19193222-003	SB145/20/22/05/24/S/01/64/EOKN	
19193222-004	SB145/20/22/05/24/S/01/64/EAKN	
19193222-005	SB145/20/22/05/24/P/01/64/EOKN	
19193228	<b>SB145 20 28 XX 28 Nm 2000 min<sup>-1</sup></b>	
19193228-001	SB145/20/28/05/24/S/01/64/EOKN	
19193228-002	SB145/20/28/05/24/P/01/64/EOKN	
19193228-003	SB145/20/28/05/24/P/01/64/DOKN	
19193228-004	SB145/20/28/05/24/S/01/64/DOKN	

Order number	Product name	Explanations
19193228-005	SB145/20/28/05/24/S/01/64/EAKN	
19193228-006	SB145/20/28/05/24/P/01/64/EAKN	
19193308	<b>SB145 30 08 XX 8 Nm 3000 min<sup>-1</sup></b>	
19193308-001	SB145/30/08/05/24/S/01/64/EAKN	
19193308-002	SB145/30/08/05/24/P/2B/64/EAKN	
19193308-003	SB145/30/08/05/24/S/01/64/BOKN	
19193308-004	SB145/30/08/05/24/P/01/64/EOKN	
19193308-005	SB145/30/08/05/24/S/01/64/EOKN	
19193308-006	SB145/30/08/05/24/P/01/64/EAKN	
19193308-007	SB145/30/08/05/24/S/01/64/SAKN	
19193308-008	SB145/30/08/05/24/P/3B/64/EOKN	
19193308-009	SB145/30/08/05/24/P/01/64/EOKN	
19193308-010	SB145/30/08/05/24/S/01/64/BAKN	
19193308-011	SB145/30/08/05/24/S/01/64/BOKN	
19193308-012	SB145/30/08/05/24/P/01/64/BAKN	
19193308-013	SB145/30/08/05/24/S/01/64/DAKN	
19193308-014	SB145/30/08/05/24/P/01/64/DAKN	
19193308-015	SB145/30/08/05/24/S/3A/64/EAKN	
19193308-016	SB145/30/08/05/24/S/3B/64/EAKN	
19193308-017	SB145/30/08/05/24/S/01/64/DOKN	
19193308-018	SB145/30/08/05/24/P/01/64/DOKN	
19193315	<b>SB145 30 15 XX 15 Nm 3000 min<sup>-1</sup></b>	
19193315-001	SB145/30/15/05/24/S/2B/64/EAKN	
19193315-002	SB145/30/15/05/24/P/01/64/SOKN	
19193315-003	SB145/30/15/05/24/S/01/64/EAKN	
19193315-004	SB145/30/15/05/24/P/01/64/EAKN	
19193315-005	SB145/30/15/05/24/P/3A/64/EAKN	
19193315-006	SB145/30/15/05/24/S/01/64/EOKN	
19193315-007	SB145/30/15/05/24/P/01/64/BOKN	
19193315-008	SB145/30/15/05/24/P/01/64/BAKN	

Order number	Product name	Explanations
19193315-009	SB145/30/15/05/24/S/01/64/SAKN	
19193315-010	SB145/30/15/05/24/P/01/64/FOKN	
19193315-011	SB145/30/15/05/24/S/01/64/DAKN	
19193315-012	SB145/30/15/05/24/P/01/64/EOKN	
19193315-013	SB145/30/15/05/24/S/01/64/DOKN	
19193315-014	SB145/30/15/05/24/P/01/64/DAKN	
19193315-015	SB145/30/15/05/24/S/01/64/EOFL	
19193322	<b>SB145 30 22 XX 22 Nm 3000 min<sup>-1</sup></b>	
19193322-001	SB145/30/22/05/24/P/01/64/SOKN	
19193322-002	SB145/30/22/05/24/P/01/64/IOKN	
19193322-003	SB145/30/22/05/24/S/01/64/EAKN	
19193322-004	SB145/30/22/05/24/P/01/64/EOKN	
19193322-005	SB145/30/22/05/24/S/01/64/EOKN	
19193322-006	SB145/30/22/05/24/S/01/64/SAKN	
19193322-007	SB145/30/22/05/24/P/01/64/EAKN	
19193322-008	SB145/30/22/05/24/S/01/64/BAKN	
19193322-009	SB145/30/22/05/24/S/01/64/BOKN	
19193322-010	SB145/30/22/05/24/P/01/64/BAKN	
19193322-011	SB145/30/22/05/24/S/01/64/SOKN	
19193322-012	SB145/30/22/05/24/S/01/64/DAKN	
19193322-013	SB145/30/22/05/24/S/01/64/DOKN	
19193328	<b>SB145 30 28 XX 28 Nm 3000 min<sup>-1</sup></b>	
19193328-001	SB145/30/28/05/24/P/01/64/EOFL	
19193328-002	SB145/30/28/05/24/P/01/64/EOKN	
19193328-003	SB145/30/28/05/24/S/01/64/EOKN	
19193328-004	SB145/30/28/05/24/S/01/64/EAKN	
19193328-005	SB145/30/28/05/24/P/01/64/EAKN	
19193328-006	SB145/30/28/05/24/P/01/64/DAKN	
19193328-007	SB145/30/28/05/24/S/01/64/DOKN	
19193328-008	SB145/30/28/05/24/S/01/64/DAKN	



Order number	Product name	Explanations
19193408	<b>SB145 40 08 XX 8 Nm 4000 min<sup>-1</sup></b>	
19193408-001	SB145/40/08/05/24/S/01/64/EAKN	
19193408-002	SB145/40/08/05/24/P/01/64/EOKN	
19193408-003	SB145/40/08/05/24/S/01/64/DOKN	
19193408-004	SB145/40/08/05/24/S/R1/64/DAKN	
19193408-005	SB145/40/08/05/24/P/01/64/DOKN	
19193408-006	SB145/40/08/05/24/P/01/64/DAKN	
19193408-007	SB145/40/08/05/24/P/01/64/EAKN	
19193408-008	SB145/40/08/05/24/S/01/64/EOKN	
19193415	<b>SB145 40 15 XX 15 Nm 4000 min<sup>-1</sup></b>	
19193415-001	SB145/40/15/05/24/S/01/64/EOKN	
19193415-002	SB145/40/15/05/24/P/01/64/EOKN	
19193415-003	SB145/40/15/05/24/P/01/64/FOKN	
19193415-004	SB145/40/15/05/24/S/01/64/EAKN	
19193415-005	SB145/40/15/05/24/S/01/64/DAKN	
19193415-006	SB145/40/15/05/24/S/01/64/EOFL	
19193422	<b>SB145 40 22 XX 22 Nm 4000 min<sup>-1</sup></b>	
19193422-001	SB145/40/22/05/24/S/01/64/EOKN	
19193422-002	SB145/40/22/05/24/P/01/64/EOKN	
19193422-003	SB145/40/22/05/24/S/01/64/SOKN	
19193422-004	SB145/40/22/05/24/S/01/64/BOKN	
19193422-005	SB145/40/22/05/24/S/01/64/DOKN	
19193422-006	SB145/40/22/05/24/S/01/64/EAKN	
19193422-007	SB145/40/22/05/24/S/01/64/DAKN	
19193422-008	SB145/40/22/05/24/P/01/64/DAKN	
19193422-009	SB145/40/22/05/24/P/01/64/EOFL	
19193428	<b>SB145 40 28 XX 28 Nm 4000 min<sup>-1</sup></b>	
19193428-001	SB145/40/28/05/24/P/01/64/BOKN	

Order number	Product name	Explanations
19193428-002	SB145/40/28/05/24/S/01/64/EOKN	
19193428-003	SB145/40/28/05/24/P/01/64/EOKN	
19193428-004	SB145/40/28/05/24/S/01/64/DAKN	
19194127	<b>SB205 10 27 XX 27 Nm 1000 min<sup>-1</sup></b>	
19194127-001	SB205/10/27/05/38/S/01/64/EOKN	
19194150	<b>SB205 10 50 XX 50 Nm 1000 min<sup>-1</sup></b>	
19194150-001	SB205/10/50/05/38/P/2B/64/EOKN	
19194150-002	SB205/10/50/05/38/S/01/64/EOKN	
19194150-003	SB205/10/50/05/38/P/01/64/EOKN	
19194170	<b>SB205 10 70 XX 70 Nm 1000 min<sup>-1</sup></b>	
19194170-001	SB205/10/70/05/38/S/01/64/EOKN	
19194190	<b>SB205 10 90 XX 90 Nm 1000 min<sup>-1</sup></b>	
19194190-001	SB205/10/90/05/38/S/01/64/EOKN	
19194227	<b>SB205 20 27 XX 27 Nm 2000 min<sup>-1</sup></b>	
19194227-001	SB205/20/27/05/38/S/01/64/EOKN	
19194227-002	SB205/20/27/05/38/P/01/64/CAKN	
19194227-003	SB205/20/27/05/38/S/01/64/EAKN	
19194227-004	SB205/20/27/05/38/P/2B/64/EOKN	
19194227-005	SB205/20/27/05/38/P/01/64/EOKN	
19194227-006	SB205/20/27/05/38/S/01/64/DOKN	
19194227-007	SB205/20/27/05/38/S/01/64/DAKN	
19194227-008	SB205/20/27/05/38/P/01/64/EAKN	
19194227-506	SB205/20/27/05/38/S/01/64/TOKN	
19194250	<b>SB205 20 50 XX 50 Nm 2000 min<sup>-1</sup></b>	
19194250-001	SB205/20/50/05/38/S/3B/64/AOKN	
19194250-002	SB205/20/50/05/38/P/01/64/EOKN	

Order number	Product name	Explanations
19194250-003	SB205/20/50/05/38/S/01/64/EOKN	
19194250-004	SB205/20/50/05/38/P/01/64/EAKN	
19194250-005	SB205/20/50/05/38/S/01/64/EAKN	
19194250-006	SB205/20/50/05/38/S/01/64/DAKN	
19194250-007	SB205/20/50/05/38/S/01/64/DOKN	
19194250-507	SB205/20/50/05/38/S/01/64/TOKN	
19194270	<b>SB205 20 70 XX 90 Nm 2000 min<sup>-1</sup></b>	
19194270-001	SB205/20/70/05/38/S/01/64/EOKN	
19194290	<b>SB205 20 90 XX 90 Nm 2000 min<sup>-1</sup></b>	
19194327	<b>SB205 30 27 XX 27 Nm 3000 min<sup>-1</sup></b>	
19194327-001	SB205/30/27/05/38/S/2B/64/EAKN	
19194327-002	SB205/30/27/05/38/S/4B/64/EAKN	
19194327-003	SB205/30/27/05/38/S/01/64/SOKN	
19194327-004	SB205/30/27/05/38/S/01/64/EOKN	
19194327-005	SB205/30/27/05/38/P/01/64/BAKN	
19194327-006	SB205/30/27/05/38/S/4B/64/EOKN	
19194327-007	SB205/30/27/05/38/P/01/64/EAKN	
19194327-008	SB205/30/27/05/38/P/01/64/CAKN	
19194327-009	SB205/30/27/05/38/S/01/64/BAKN	
19194327-010	SB205/30/27/05/38/P/01/64/EOKN	
19194327-011	SB205/30/27/05/38/P/01/64/DAKN	
19194327-012	SB205/30/27/05/38/S/01/64/DAKN	
19194327-013	SB205/30/27/05/38/S/01/64/DOKN	
19194327-014	SB205/30/27/05/38/S/01/64/EAKN	
19194327-512	SB205/30/27/05/38/S/01/64/TAKN	
19194350	<b>SB205 30 50 XX 50 Nm 3000 min<sup>-1</sup></b>	
19194350-001	SB205/30/50/05/38/S/01/64/EOKN	
19194350-002	SB205/30/50/05/38/P/01/64/AOKN	

Order number	Product name	Explanations
19194350-003	SB205/30/50/05/38/P/01/64/AAKN	
19194350-004	SB205/30/50/05/38/P/01/64/BAKN	
19194350-005	SB205/30/50/05/38/S/01/64/DAKN	
19194350-006	SB205/30/50/05/38/P/01/64/DAKN	
19194350-007	SB205/30/50/05/38/P/01/64/EAKN	
19194350-008	SB205/30/50/05/38/S/01/64/DOKN	
19194350-009	SB205/30/50/05/38/S/01/64/BAKN	
19194350-010	SB205/30/50/05/38/S/01/64/DOFL	
19194350-011	SB205/30/50/05/38/S/01/64/EAKN	
19194350-505	SB205/30/50/05/38/S/01/64/TAKN	
19194350-510	SB205/30/50/05/38/S/01/64/TOFL	
19194370	<b>SB205 30 70 XX 70 Nm 3000 min<sup>-1</sup></b>	
19194390	<b>SB205 30 90 XX 90 Nm 3000 min<sup>-1</sup></b>	
19194390-001	SB205/30/90/05/38/P/01/64/BAKN	
19194390-002	SB205/30/90/05/38/P/01/64/BOKN	
19194390-003	SB205/30/90/05/38/S/01/64/DOKN	
19194390-004	SB205/30/90/05/38/S/01/64/EAKN	
19194390-005	SB205/30/90/05/38/P/01/64/EOKN	
19194390-006	SB205/30/90/05/38/P/01/64/DOKN	
19194390-007	SB205/30/90/05/38/S/01/64/DOFL	
19194390-506	SB205/30/90/05/38/P/01/64/TOKN	
19194390-507	SB205/30/90/05/38/S/01/64/TOFL	
19194390-509	SB205/30/90/05/38/P/01/64/TOFL	

*Tabelle 6-2: Order numbers for SB motor*

## 6.9.2 Cable

### Motor cables

Order number	Product name	Explanations
15 15 02 52	E-MO-040 cables 1,5 mm <sup>2</sup> (SB070 / SB105)	PMC-2 X2
15 15 02 54	E-MO-042 cables 1,5 mm <sup>2</sup> (angled) (SB070 / SB105)	PMC-2 X2
15 15 02 32	E-MO-031 extension 1,5 mm <sup>2</sup> (SB070 / SB105)	E-MO-040/042
15 15 02 88	E-MO-057 extension 1,5 mm <sup>2</sup> (angled) (SB070 / SB105)	E-MO-040
15 15 02 53	E-MO-041 cables 1,5 mm <sup>2</sup> (SB145)	PMC-2 X2
15 15 02 33	E-MO-032 extension 1,5 mm <sup>2</sup> (SB145)	E-MO-041
15 15 41 09	E-MO-079 1,5 mm <sup>2</sup> (SB145)	MC-4 X4
15 15 02 55	E-MO-043 2,5 mm <sup>2</sup> (SB145)	PMC-2 X2
15 15 02 63	E-MO-046 2,5 mm <sup>2</sup> (angled) (SB145)	PMC-2 X2
15 15 02 34	E-MO-033 extension 2,5 mm <sup>2</sup> (SB145)	E-MO-043/046
15 15 02 87	E-MO-056 extension 2,5 mm <sup>2</sup> (angled) (SB145)	E-MO-043
15 15 41 10	E-MO-080 2,5 mm <sup>2</sup> (SB145)	MC-4 X4
15 15 02 56	E-MO-044 2,5 mm <sup>2</sup> (SB205)	PMC-2/X2
15 15 02 36	E-MO-035 extension 2,5 mm <sup>2</sup> (SB205)	E-MO-044
15 15 41 11	E-MO-081 2,5 mm <sup>2</sup> (SB205)	MC-4 X4
15 15 02 80	E-MO-051 4 mm <sup>2</sup> (SB205)	PMC-2 X2
15 15 02 79	E-MO-050 4 mm <sup>2</sup> (angled) (SB205)	PMC-2 X2
15 15 02 74	E-MO-048 extension 4 mm <sup>2</sup> (SB205)	E-MO-051/050

Order number	Product name	Explanations
15 15 02 86	E-MO-055 extension 4 mm <sup>2</sup> (angled) (SB205)	E-MO-051
15 15 41 19	E-MO-090 10 mm <sup>2</sup> (SB205/30/90 connection box)	MC-4 / 50 A

Table 6-3: Order numbers for motor cables

### Brake cables

Order number	Product name	Explanations
15 15 02 27	E-MO-027 SB070...205 brake	
15 15 02 78	E-MO-049 SB070...205 brake (angled)	
15 15 02 40	E-MO-037 SB070...205 extension for brake	

Table 6-4: Order numbers for brake cables

### Encoder cables

Order number	Product name	Explanations
15 15 02 38	E-TA-013 SB070...205 resolver	X6
15 15 02 64	E-TA-016 SB070...205 resolver (angled)	X6
15 15 02 39	E-TA-014 SB070...205 resolver extension	
15 15 02 89	E-TA-017 SB070...205 resolver (angled) extension	

Table 6-5: Order numbers for encoder cables

## 7 Technical Data

### 7.1 General Technical Data

#### 7.1.1 Definitions and Physical Correlations

Abbrev.	Unit	Definition
$I_{0M}$	[A]	standstill current of the motor effective value of the motor current at standstill torque $M_0$
$I_{NM}$	[A]	rated motor current effective value of the motor current at rated torque $M_N$
$I_{SM}$	[A]	peak motor current effective value of the motor current at peak torque $M_{SM}$
$I_{NC}$	[A]	rated current of MotorController rated controller current (permanent operation S1)
$I_{SC}$	[A]	peak current of the MotorController peak current of the controller for acceleration phases also effective value of the motor current at peak torque $M_{SA}$ supplied for a short time by the drive combination
$J_M$	[kgcm <sup>2</sup> ]	rotor moment of inertia the rotor moment of inertia refers to a motor with resolver and without brake
$J_{ges}$	[kgcm <sup>2</sup> ]	moment of inertia total moment of inertia (motor and load)
$K_M$	[Nm/A]	torque constant of the motor ratio of standstill torque $M_0$ and standstill current $I_{0M}$ (e.g. $K_{M20}$ for 20°C).
m	[kg]	mass motor mass without brake and without fan
$M_0$	[Nm]	standstill torque of the motor permanent torque (100% ED) at speed $n_0$ . With an ambient temperature of 40 °C, an overtemperature of 60 °C occurs on the motor casing, depending on the thermal motor time constant
$M_N$	[Nm]	rated motor torque permanent torque (100% ED) at rated speed $n_N$ . Due to the speed-related losses, it is less than $M_0$ . With an ambient temperature of 40 °C, an overtemperature of 60 °C occurs on the motor casing, depending on the thermal motor time constant
$M_{S3}$	[Nm]	torque for intermittent operation S3 = 25% ED

Abbrev.	Unit	Definition
$M_{SA}$	[Nm]	peak motor torque of motor in combination with Motor Controller
$M_{SM}$	[Nm]	peak motor torque maximum torque which a servo motor can deliver on the working shaft for a short time
$n_{NM}$	[1/min]	rated motor speed speed that can be used at rated torque. Idling speed $n_L$ and mechanical limit speed $n_{limit}$ of the servo motor are higher
$P_{NM}$	[kW]	rated mechanical power rated mechanical power of the servo motor according to rated speed $n_N$ and rated torque $M_N$ .
$P_{NA}$	[kW]	rated motor power in combination with controller
$P_{ECKM}$	[kW]	fringe motor power (theoretical value) $P_{FRINGEM} = M_{0M} * n_N * \pi / 30$
$R_W$	[ $\Omega$ ]	resistance of a motor winding resistance of a motor winding between phase and neutral point (e.g. $R_{W20}$ for a winding temperature of 20 °C).
$L_W$	[mH]	winding inductivity winding inductivity for a winding temperature of 20 °C
$t_{bSM}$	[ms]	acceleration time acceleration time of the motor without external torque from 0 to rated speed $n_N$ with peak motor current $I_{SM}$ .

Table 7-1: Physical definitions with units



### physical correlations

#### Correlation between torque and current:

$$M = K_M \times I_{\text{eff}}$$

M in Nm

$K_M$  in Nm/A

$I_{\text{eff}}$  in A (effective value of the phase current)

#### Current:

$$I_{\text{eff}} = \frac{I_{\text{summit}}}{1,41}$$

$I_{\text{eff}}$  and  $I_{\text{summit}}$  in A

#### Rated motor power:

$$P_{NM} = M_N \times n_N \times \frac{\pi}{30}$$

$P_{NM}$  in Watt

$M_N$  in Nm

$n_N$  in rpm

#### Admissible working time in AB operation (S3) with a play duration of 15 minutes:

$$ED = \left( \frac{M_N}{M_{S3}} \right)^2 \times 100$$

ED in %

$M_N$  and  $M_{S3}$  in Nm

#### Effective torque with changing loads:

$$M_{\text{eff}} < M_N$$

$$M_{\text{eff}} = \sqrt{\frac{M_1^2 \times t_1 + M_2^2 \times t_2 + \dots + M_n^2 \times t_n}{t_1 + t_2 + \dots + t_n}}$$

Speed:

$$= \frac{n \times 2 \times \pi}{60}$$

w in rad/sec

n in rpm

Acceleration moment:

$$M_b = I_{\text{total}} \times \left( \frac{w}{t_b} \right)$$

 $M_b$  in Nm $I_{\text{ges}}$  in  $\text{kgm}^2$ 

w in rad/sec

 $t_b$  in sec (acceleration time)Acceleration:

$$a = \frac{w}{t_b}$$

a in  $\text{rad/sec}^2$ 

w in rad/sec

 $t_b$  in sec

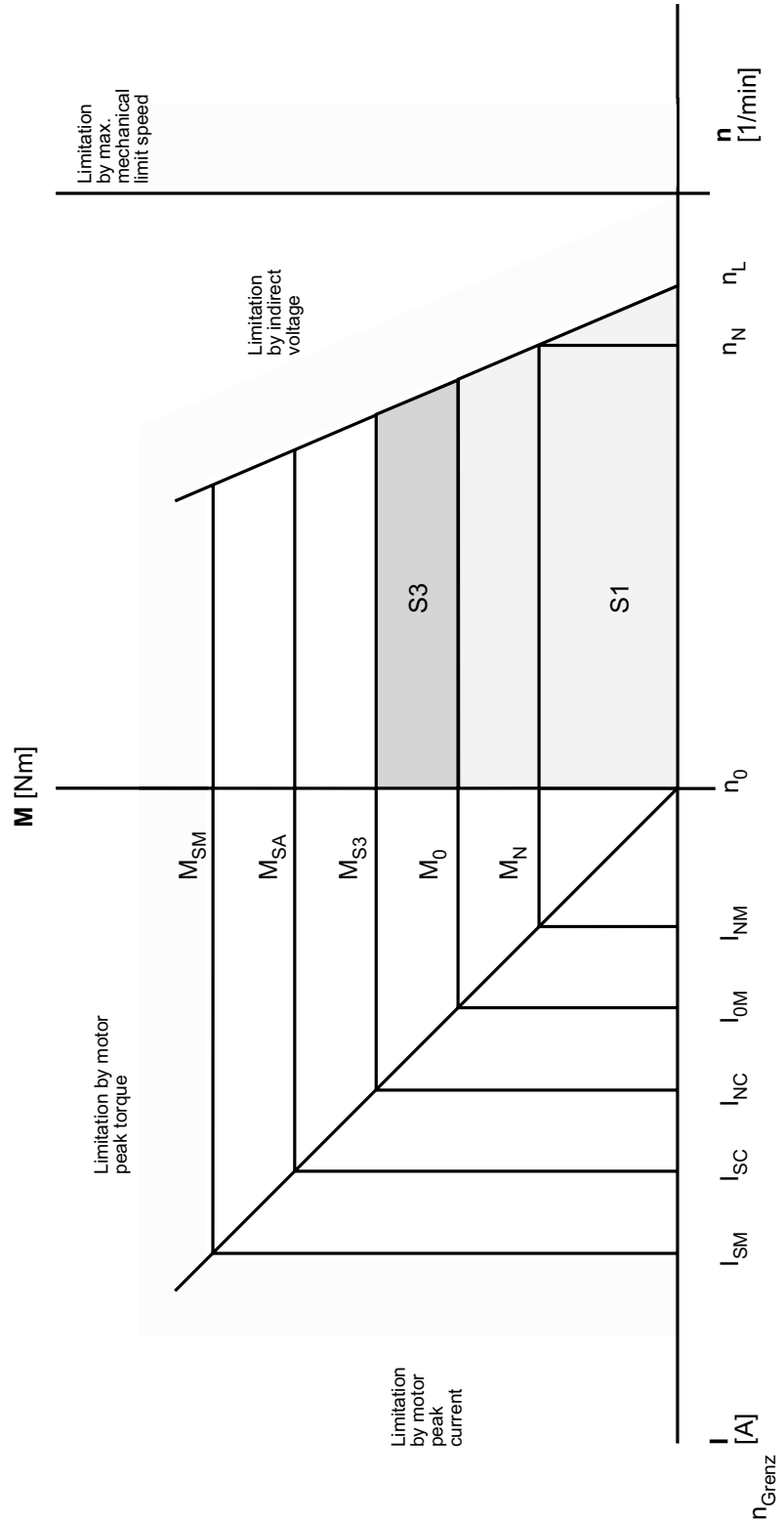

Fig. 7-1: Physical correlations

## 7.1.2 Ambient conditions, approbations

Parameter	Value
admissible ambient temperature	0 - 40 °C with higher temperatures, power reduction by 2% per °C
air humidity	class F according to DIN 40040
insulation class	F
approbations	UL / cUL on request

Table 7-2: Ambient conditions, approbations

## 7.1.3 Protection means

The protection means of the motor depends on the position in which it is mounted.

All motor types have a fixing flange that makes it possible to install them according to method B5 (fixing flange with through holes).

According to DIN 42950 part 1 (edition 08.77), the motors can be mounted on the machine as follows:



Structural shape	Admissible mounting positions according to DIN IEC 34-7		
B05	 IM B5	 IM V1	 IM V3

Fig. 7-2: Mounting positions of the motor

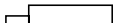

### CAUTION!

Penetrating liquid causes motor damage!

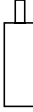
When installing the motor in position IM V3, make sure that there are no liquids at the drive shaft for a longer time. Even if a shaft seal is built in, one cannot rule out with absolute certainty that liquid penetrates into the motor casing along the drive shaft.

Motor part	Protection class	Mounting position
shaft	IP 64 <b>IP 60</b>	IM B5, IM V1 <b>IM V3</b>
surface	IP 64	IM B5, IM V1, IM V3
Stecker Motor	<b>IP 60</b>	IM B5, IM V1, IM V3
Lüfter (Option)	IP 20	IM B5, IM V1, IM V3

Table 7-3: Protection means of SB Motors

## 7.1.4 Motor shaft and bearing

### Execution of the shaft end

Smooth shaft end (standard)

With a frictional connection, torque transmission must be achieved by pressure only. This ensures a safe load transmission without play.

Manufacturer	Designation	Remarks
Fa. KTR Kupplungstechnik GmbH Rodder Damm 170 48432 Rheine	CLAMPEX clamp set	SB 056: KTR 250 - 11x18 SB 070: KTR 250 - 11x18
Fa. Spieth Maschinenelemente Alleenstraße 41 73730 Esslingen	Spieth pressure sleeve series DSM	SB 105: DSM 19.2 SB 145: DSM 24.2 SB 205: DSM 38.2

Table 7-4: Manufacturers of frictional connections

Shaft end with featherkey way according to DIN 6885

Shaft connections with feather are form-fit. Under continuous duty with variable torque rates or high reversing activity, the position of the feather may deflect. This reduces the quality of smooth running (a ply develops!). Increasing deformation may cause the feather to break and thus damage the shaft. For this reason, this kind of shaft-hub connection is suitable only for low strain. We recommend using smooth shaft ends.

### Bearing

The bearing on the A side is a fixed bearing, on the B side is a loose bearing. Thus heat expansion of the slide has no effect on the A side.

### Admissible shaft strain

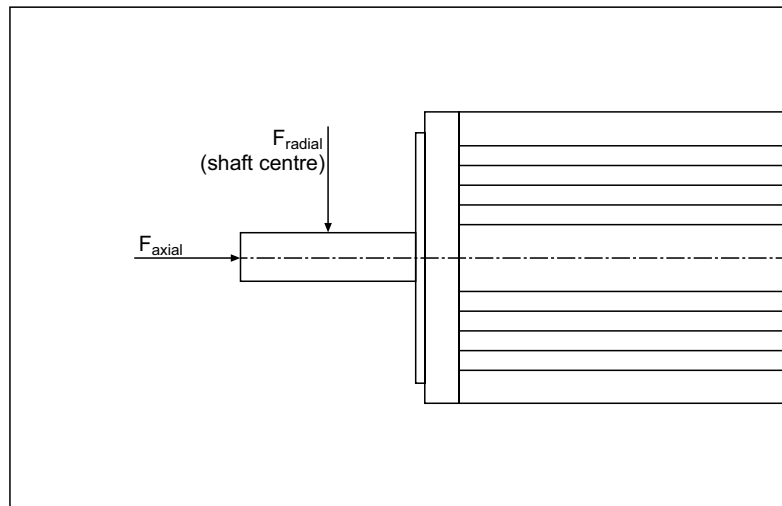

Fig. 7-3: Definition of shaft strain

Motor	1000 1/ min	2000 1/ min	3000 1/ min	4000 1/ min	5000 1/ min	6000 1/ min
SB056xx06	388	318	274	249	231	
SB070xx05	527	431	372	337	312	295
SB070xx10	546	447	398	360	324	306
SB070xx15	589	482	416	376	350	330
SB070xx20	607	497	428	388	360	340
SB105xx02	927	755	652	590		
SB105xx04	1000	820	710	643		
SB105xx06	1061	866	750	679		
SB105xx08	1100	896	775	701		
SB145xx08	1335	1095	940	851		
SB145xx15	1445	1185	1020	923		
SB145xx22	1515	1240	1070	968		
SB145xx28	1560	1280	1100	996		
SB205xx27	3435	2850	2430			
SB205xx50	3750	3070	2650			
SB205xx70	3950	3235	2790			
SB205xx90	4100	3350	2890			

Table 7-5: Admissible radial force  $F_{\text{radial}}$  [N]

Basis for calculation:

20.000 hours of operation as rated bearing life  $L_{10h}$  for a shaft without feather groove.

admissible axial force  $F_{axial}$  [N]

$$F_{axial} = 0,2 \times F_{radial}$$

## 7.1.5 Encoder

### SinCos

Parameter	Value	Unit
number of sinus-cosine phases per revolution	1024	
rotor moment of inertia	10	gcm <sup>2</sup>
code type for absolute value	binary	
code development for clockwise shaft rotation, looking on >A< (see dimensional drawing)	rising	
measuring step after arc tangent formation with 12 bit resolution	0.3	angular seconds
number of steps per revolution „SRS single-turn“	32.768	
number of steps per revolution „SRM multi-turn“	134.217.728 = 32768 x 4096	
error limits of the digital absolute value via RS 485	+/- 90	angular minutes
error limits for evaluation of the 1024-type signals, integral non-linearity	+/- 45	angular minutes
non-linearity within a sinus, cosine period, differential non-linearity	+/- 7	angular seconds
output frequency for sinus, cosine signals	0 ... 200	kHz
working speed up to which the absolute position can be formed reliably	6000	min <sup>-1</sup>
max. angular acceleration	0.2 x 10 <sup>6</sup>	rad/s <sup>2</sup>
operating torque	0.2	Ncm
starting torque	0.4	Ncm

Parameter	Value	Unit
admissible shaft movements		
- radial movement, static	+/- 0.5	mm
- radial movement, dynamic	+/- 0.1	mm
- axial movement, static	+/- 0.75	mm
- axial movement, dynamic	+/- 0.2	mm
- angular movement at right angle to turning axis, static	+/- 0.005	mm/mm
- angular movement at right angle to turning axis, dynamic	+/- 0.0025	mm/mm
bearing life	$3.6 \times 10^9$	revolutions
working temperature range	-20 ... +115	°Celsius
operating temperature range	-20 ... +125	°Celsius
storage temperature range	-40 ... +125	°Celsius
admissible relative air humidity (dewing prohibited)	90	%
shock resistance when mounted according to DIN IEC 68 part 2-27	100/10	g/ms
vibration resistance when mounted according to DIN IEC 68 part 2-6	20/10 ... 2000	g/Hz
protection means according to DIN VDE 0470 part 1 when mounted	IP 40	
EMT according to EN 50082-2 and EN 50081-2		
operating voltage range	7 ... 12	V
recommended supply voltage	8	V
max. operating current without load	80	mA
available memory range in EEPROM	128	Byte
interface signals SIN, REFSIN, COS, REFCOS = process data channel RS 485 = parameter channel	analog, differential, digital	

Table 7-6: Technical data of the SinCos encoder (SRS / SRM)

## Resolver

The SM motor can be supplied also with a brushless hollow shaft resolver.

### Advantages of brushless hollow shaft resolvers

Brushless resolvers enable exact positioning, number of revolutions entry and commutation of brushless electric motors without mechanical or temperature-dependent restrictions, as them admit from other sensors are.



Brushless resolvers are outstanding for the industrial application under rough environmental conditions. Specially, they are to a large extent insensitive to vibration, shock and increased temperature stress.

#### Outstanding features

- compact execution
- assembly directly on motor or drive shaft, no clutch
- no brushes or contacts
- no ball bearings
- compatible with resolver / digital transducer

### 7.1.6 Holding brake (optional)

---

To hold the axis without play in standstill or while the plant is powerless, the servo motors can be supplied with a holding brake. The holding brake works according to the zero current principle and is thus a safety brake. In currentless state a spring force acts on the brake anchor disk, i.e. the brake is closed and holding the axis. By applying 24 V DC, the spring force is lifted by the electric field and the brake is opened.



---

#### **DANGER!**

Descending axes!

Persons run the risk of squeezing or cutting off limbs.

- The holding brake alone does not guarantee personal protection. To protect people, provide for superior constructive measures, e.g. protective grid, or furnish the plant with a second brake.
- 



---

#### **CAUTION!**

Holding brake may wear out prematurely!

Risk of personal injury!

- Do not use the holding brake for operating stop of a moving axis! This is only admissible for EMERGENCY STOP situations.
- 

The motors must not be operated against the closed brake. An emergency stop of the motor (i.e., the brake drops while the motor is running) is only admissible in exceptional cases.

**NOTE**

There are only a few diagnosis messages of the MotorController (MC-4 diagnosis messages with reaction A) which do not permit a controlled stop of the motor. In these few cases, the holding brake of the motor is required for the complete brake procedure (EMERGENCY STOP).

The times are valid for direct current, regular operating temperature and rated voltage. *Separation time* is the time from switching on the power to the point when the torque has faded to 10% of the rated torque. *Connection time* is the time from switching off the power until the rated torque is reached.

**CAUTION!**

Power loss in case of long cables!

The brake may be worn out or damaged!

- The data for rated power and rated voltage apply at the connection box. Check the data at the connection box. A higher or separate power supply of the brake may be necessary. A too high voltage can also damage the brake!

	SB 056	SB 070	SB 105	SB 145	SB 205	Unit
holding moment	0,8	1,5	5	15	50	[Nm] ([lb-in.])
connection time	80	80	80	80	80	[ms]
separation time	200	200	200	200	200	[ms]
mass	0,8	2	3	5	14	[kg]
moment of inertia	0,17	0,4	0,63	1,95	10	[kgcm <sup>2</sup> ] ([lb-in.-s <sup>2</sup> ])
rated power	0,4	0,6	1,1	1,9	1,7	[W]
rated voltage	24 +/-10%	24 +/-10%	24 +/-10%	24 +/-10%	24 +/-10%	[V] DC

Table 7-7: Technical data of the holding brake of the SB Motor

### 7.1.7 Surface ventilation (optional)

To increase the permanent motor torque, the SB Motors can be supplied with surface ventilation.

The surface ventilation reduces the thermal transition resistance, so that the permanent torque characteristics of the motor are shifted upwards. The peak motor torque is not changed.

The increased permanent torque values are saved in the electronic type plate of the motor or the motor database.

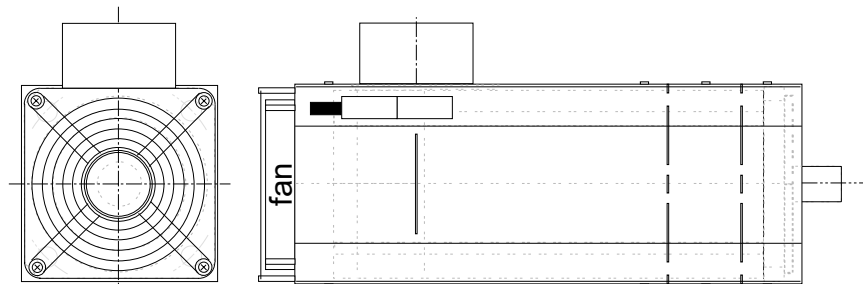

Fig. 7-4: Example for an SB Motor with surface ventilation

The fan is dimensioned differently for each motor series:

	SB 056	SB 070	SB 105	SB 145	SB 205	Einheit
rated voltage	not available	230	230	230	400 V <b>3 AC</b>	[V] AC
power intake	not available	ca. 0,08	ca. 0,13	ca. 0,23	ca. 0,15	[A]

Table 7-8: Technical data of the fans

## 7.1.8 Technical Data in Detail

### Technical Data SB 056 50

values are applied to flange-mounted motor at aluminium-plate 140 x 140 x 10 mm

Referenz Data	mne- monic	50 06		Unit
Standstill torque(standard) -motor with surface ventilation	$M_{0M}$	0,7		[Nm]
Rated speed	$n_N$	5000		[UPM]
fringe motor power	$P_{ECKM}$	0,4		[kW]
Peak torque(120°C)	$M_{SM}$	3,2		[Nm]
<b>physical data</b>				
max. mechanical limit rpm	$n_{limit}$	700		[rad/s]
Motor's moment of inertia	$J_M$	0,21		[rad/s <sup>2</sup> ]
acceleration on $M_{SM}$	$A_{SM}$	153949		[rad/s <sup>2</sup> ]
max. shock(all direction)	S	200		[m/s <sup>2</sup> ]
max. vibration (radial)	$V_R$	200		[m/s <sup>2</sup> ]
max. vibration (axial)	$V_A$	40		[m/s <sup>2</sup> ]
mass	m	1,3		[kg]
run-up time	$t_{bSM}$	3,4		[ms]
<b>thermal data</b>				
thermal time constant	$t_A$	58		[min]
Operating threshold thermo contact	$T_{TK}$	130		[°C]
<b>electrical data</b>				
number of poles	PZ	4		
circuit of the motor windings		Y		
Torque constant(20°C)	$K_{M20}$	0,99		[Nm/A]
torque constant(120°C)	$K_{M120}$	0,90		[Nm/A]
Winding resistance(20°C)	$R_{W20}$	22,3		[Ohm]
Winding inductivity(20°C)	$L_W$	60		[mH]
EMK at 1000 rpm	EMK	60		[V]
Stillstand current	$I_{0M}$	0,83		[A]
Peak current	$I_{SM}$	3,6		[A]

Table 7-9: Technical data SB 056 50 (3AC 400V)

**Technical Data SB 070 40**

Values are applied to flange-mounted motor at aluminium-plate  
175 x 175 x 10 mm

Reference Data	mne- monic	4005	4010	4015	4020	Unit
Standstill torque (standard) -motor with surface ventilation	$M_{0M}$	0,7	1,3	1,8	2,3	[Nm]
Rated speed	$n_N$	4000	4000	4000	4000	[UPM]
fringe motor power	$P_{ECKM}$	0,3	0,5	0,7	1,0	[kW]
Peak torque(120°C)	$M_{SM}$	2,9	5,5	6,7	9,0	[Nm]
<b>physical data</b>						
max. mechanical limit rpm	$n_{limit}$	700	700	700	700	[rad/s]
Motor's moment of inertia	$J_M$	0,26	0,4	0,54	0,68	[kgcm <sup>2</sup> ]
acceleration of $M_{SM}$	$A_{SM}$	118454	143684	141515	144086	[rad/s <sup>2</sup> ]
max. shock (all directions)	S	200	200	200	200	[m/s <sup>2</sup> ]
max. vibration(radial)	$V_R$	200	200	200	200	[m/s <sup>2</sup> ]
max. vibration(axial)	$V_A$	40	40	40	40	[m/s <sup>2</sup> ]
Mass	m	2	2,75	3,5	4,25	[kg]
run-up time	$t_{bSM}$	3,5	2,9	3,0	2,9	[ms]
<b>thermal data</b>						
thermal time constant	$t_A$	58	59	60	60	[min]
Operating threshold thermo contact	$T_{TK}$	130	130	130	130	[°C]
<b>elektrical data</b>						
Number of poles	PZ	4	4	4	4	
Circuit of the motor windings		Y	Y	Y	Y	
Torque constant (20°C)	$K_{M20}$	1,17	1,21	1,23	1,25	[Nm/A]
Torque constant (120°C)	$K_{M120}$	1,06	1,10	1,12	1,13	[Nm/A]
Winding resistance (20°C)	$R_{W20}$	45,5	15,9	9,75	6,50	[Ohm]
Winding inductivity (20°C)	$L_W$	80,4	43,2	29,68	22,93	[mH]
EMK at 1000 rpm	EMK	71	73	74	75	[V]
Standstill current	$I_{0M}$	0,66	1,17	1,57	2,01	[A]
Peak current	$I_{SM}$	2,7	5	6	8	[A]

Table 7-10: Technical data SB 070 40 (3AC 400V)

### Technical Data SB 070 60

Values are applied to flange- mounted motor at aluminium plate  
175 x 175 x 10 mm

Reference Data	mne- monic	6005	6010	6015	6020	Unit
Standstill torque (standard) - motor with surface ventilation	$M_{0M}$	0,7	1,3	1,7	2,3	[Nm]
Rated speed	$n_N$	6000	6000	6000	6000	[UPM]
fringe motor power	$P_{ECKM}$	0,5	0,8	1,1	1,4	[kW]
Peak torque (120°C)	$M_{SM}$	2,9	5,2	6,8	8,8	[Nm]
<b>physical data</b>						
max. mechanical limit rpm	$n_{limit}$	700	700	700	700	[rad/s]
Motor's moment of inertia	$J_M$	0,26	0,4	0,54	0,68	[kgcm <sup>2</sup> ]
acceleration of $M_{SM}$	$A_{SM}$	118822	142497	141747	144086	[rad/s <sup>2</sup> ]
max. shock (all directions )	S	200	200	200	200	[m/s <sup>2</sup> ]
max. vibrations (radial)	$V_R$	200	200	200	200	[m/s <sup>2</sup> ]
max. vibrations (axial)	$V_A$	40	40	40	40	[m/s <sup>2</sup> ]
Mass	m	2	2,75	3,5	4,25	[kg]
run-up time	$t_{bSM}$	5,3	4,4	4,4	4,4	[ms]
<b>thermal data</b>						
thermal time constant	$t_A$	58	59	60	60	[min]
Operating threshold thermo contact	$T_{TK}$	130	130	130	130	[°C]
<b>elektrical data</b>						
Number of poles	PZ	4	4	4	4	
Circuit of the motor windings		Y	Y	Y	Y	
Torque constant(20°C)	$K_{M20}$	0,81	0,84	0,84	0,88	[Nm/A]
Torque constant(120°C)	$K_{M120}$	0,74	0,76	0,76	0,80	[Nm/A]
Winding resistance(20°C)	$R_{W20}$	21,6	7,85	4,60	3,25	[Ohm]
Winding inductivity(20°C)	$L_W$	38,4	20,985	13,99	11,425	[mH]
EMK at 1000 rpm	EMK	49	51	51	53	[V]
Standstill current	$I_{0M}$	0,96	1,67	2,29	2,84	[A]
Peak current	$I_{SM}$	3,9	6,8	9	11	[A]

Table 7-11: Technical data SB 070 60 (3AC 400V)

**Technical Data SB 105 20**

Values are applied to flange-mounted motor at aluminum- plate  
262,5 x 262,5 x 10 mm

Reference Data	mne- monic	2002	2004	2006	2008	Unit
Standstill torque (standard) -motor with surface ventilation	$M_{OM}$	3,0	5,3	7,4	9,4 14	[Nm]
Rated speed	$n_N$	2000	2000	2000	2000	[UPM]
fringe motor power	$P_{ECKM}$	0,6	1,1	1,6	2,0	[kW]
Peak torque(120°C)	$M_{SM}$	13	20	27,1	32,3	[Nm]
<b>physical data</b>						
max. mechanical limit rpm	$n_{limit}$	700	700	700	700	[rad/s]
Motor's moment of inertia	$J_M$	1,9	3,4	4,8	6,2	[kgcm <sup>2</sup> ]
Acceleration of $M_{SM}$	$A_{SM}$	51034	48532	44943	42048	[rad/s <sup>2</sup> ]
max. shock (all directions)	S	200	200	200	200	[m/s <sup>2</sup> ]
max. vibrations (radial)	$V_R$	200	200	200	200	[m/s <sup>2</sup> ]
max. vibrations (axial)	$V_A$	50	40	40	40	[m/s <sup>2</sup> ]
Mass	m	4,9	7	9,1	11,2	[kg]
run-up time	$t_{bSM}$	4,1	4,3	4,7	5,0	[ms]
<b>thermal data</b>						
thermal time constant	$t_A$	51	60	65	69	[min]
Operating of the motor windings	$T_{TK}$	130	130	130	130	[°C]
<b>electrical data</b>						
Number of poles	PZ	8	8	8	8	
Circuit of the motor windings		Y	Y	Y	Y	
Torque constant (20°C)	$K_{M20}$	2,34	2,42	2,48	2,54	[Nm/A]
Torque constant (120°C)	$K_{M120}$	2,13	2,20	2,26	2,31	[Nm/A]
Winding resistance (20°C)	$R_{W20}$	19,1	7,33	4,43	3,21	[Ohm]
Winding inductivity (20°C)	$L_W$	49,76	26,665	18,595	14,575	[mH]
EMK at 1000 rpm	EMK	142	147	150	153	[V]
Standstill current	$I_{OM}$	1,42	2,42	3,28	4,05	[A]
Peak current	$I_{SM}$	6	9	12	14	[A]

Table 7-12: Technical data SB 105 20 (3AC 400V)

### Technical Data SB 105 30

Values are applied to flange-mounted motor at aluminium-plate  
262,5 x 262,5 x 10 mm

Reference Data	mne- monic	3002	3004	3006	3008	Unit
Standstill torque (standard) -motor with surface ventilation	$M_{0M}$	3,0	5,3	7,4	9,3 16	[Nm]
Rated speed	$n_N$	3000	3000	3000	3000	[UPM]
fringe motor power	$P_{ECKM}$	1,0	1,7	2,3	2,9	[kW]
Peak torque(120°C)	$M_{SM}$	10,4	18,0	24,0	30,0	[Nm]
<b>physical Data</b>						
max. mechanical limit rpm	$n_{limit}$	700	700	700	700	[rad/s]
Motor's moment of inertia	$J_M$	1,9	3,4	4,8	6,2	[kgcm <sup>2</sup> ]
Acceleration at $M_{SM}$	$A_{SM}$	45008	42801	39636	37083	[rad/s <sup>2</sup> ]
max. shock (all directions)	S	200	200	200	200	[m/s <sup>2</sup> ]
max. vibration (radial)	$V_R$	200	200	200	200	[m/s <sup>2</sup> ]
max. vibration (axial)	$V_A$	50	40	40	40	[m/s <sup>2</sup> ]
Mass	m	4,9	7	9,1	11,2	[kg]
run-up time	$t_{bSM}$	7,0	7,3	7,9	8,5	[ms]
<b>thermal data</b>						
thermal time constant	$t_A$	51	60	65	69	[min]
Operating threshold thermo contact	$T_{TK}$	130	130	130	130	[°C]
<b>electrical data</b>						
Number of poles	PZ	8	8	8	8	
Circuit of the motor windings		Y	Y	Y	Y	
Torque constant(20°C)	$K_{M20}$	1,63	1,65	1,65	1,65	[Nm/A]
Torque constant(120°C)	$K_{M120}$	1,48	1,5	1,5	1,5	[Nm/A]
Winding resistance(20°C)	$R_{W20}$	9,21	3,41	1,97	1,37	[Ohm]
Winding inductivity (20°C)	$L_W$	23,975	12,395	8,265	6,2	[mH]
EMK at1000 rpm	EMK	98	100	100	100	[V]
Standstill current	$I_{0M}$	2,04	3,55	4,93	6,21	[A]
Peak current	$I_{SM}$	7	12	16	20	[A]

Table 7-13: Technical data SB 105 30 (3AC 400V)



**Technical Data SB 105 40**

Values are applied to flange-mounted motor at aluminium-plate  
262,5 x 262,5 x 10 mm

Reference Data	mne- monic	4002	4004	4006	4008	Unit
Standstill torque (standard) -motor with surface ventilation	$M_{0M}$	3,0	5,4 8,7	7,4	8,5 14	[Nm]
Rated speed	$n_N$	4000	4000	4000	4000	[UPM]
fringe motor power	$P_{ECKM}$	1,3	2,3	3,1	3,6	[kW]
Peak current (120°C)	$M_{SM}$	10,2	18,6	24,0	28,8	[Nm]
<b>physical data</b>						
max. mechanical limit rpm	$n_{limit}$	700	700	700	700	[rad/s]
Motor's moment of inertia	$J_M$	1,9	3,4	4,8	6,2	[kgcm <sup>2</sup> ]
Acceleration at $M_{SM}$	$A_{SM}$	45008	42801	39636	37083	[rad/s <sup>2</sup> ]
max. shock (all directions)	S	200	200	200	200	[m/s <sup>2</sup> ]
max. vibration (radial)	$V_R$	200	200	200	200	[m/s <sup>2</sup> ]
max. vibration (axial)	$V_A$	50	40	40	40	[m/s <sup>2</sup> ]
Mass	m	4,9	7	9,1	11,2	[kg]
run-up time	$t_{bSM}$	9,3	9,8	11	11	[ms]
<b>thermal data</b>						
thermal time constant	$t_A$	51	60	65	69	[min]
Operating threshold thermo contact	$T_{TK}$	130	130	130	130	[°C]
<b>elektrical data</b>						
Number of poles	PZ	8	8	8	8	
Circuit of the motor windings		Y	Y	Y	Y	
Torque constant (20°C)	$K_{M20}$	1,24	1,27	1,32	1,32	[Nm/A]
Torque constant (120°C)	$K_{M120}$	1,13	1,16	1,2	1,2	[Nm/A]
Winding resistance (20°C)	$R_{W20}$	5,36	2,00	1,26	1,05	[Ohm]
Winding inductivity(20°C)	$L_W$	13,9	7,29	5,29	3,97	[mH]
EMK at1000 rpm	EMK	75	77	80	80	[V]
Standstill current	$I_{0M}$	2,67	4,63	6,16	7,08	[A]
Peak current	$I_{SM}$	9	16	20	24	[A]

Table 7-14: Technical data SB 105 40 (3AC 400V)

### Technical Data SB 145 20

Values are applied to flange-mounted motor at aluminium-plate  
362,5 x 362,5 x 10 mm

Reference Data	mne- monic	2008	2015	2022	2028	Unit
Standstill torque (standard) -motor with surface ventilation	M <sub>0M</sub>	11	19	28	35	[Nm]
Rated speed	n <sub>N</sub>	2000	2000	2000	2000	[UPM]
fringe motor power	P <sub>ECKM</sub>	2,3	4,1	5,9	7,4	[kW]
Peak current (120°C)	M <sub>SM</sub>	36,6	65,0	92,8	113	[Nm]
<b>physical data</b>						
max. mechanical limit rpm	n <sub>Grenz</sub>	700	700	700	700	[rad/s]
Motor's moment of inertia	J <sub>M</sub>	10,5	16	21,54	27	[kgcm <sup>2</sup> ]
Acceleration at M <sub>SM</sub>	A <sub>SM</sub>	38974	44730	47294	45456	[rad/s <sup>2</sup> ]
max. shock (all directions)	S	200	200	200	200	[m/s <sup>2</sup> ]
max. vibration (radial)	V <sub>R</sub>	200	200	200	200	[m/s <sup>2</sup> ]
max. vibration (axial)	V <sub>A</sub>	40	40	40	40	[m/s <sup>2</sup> ]
Mass	m	10	14	18	22	[kg]
run-up time	t <sub>bSM</sub>	5,4	4,7	4,4	4,6	[ms]
<b>thermal data</b>						
thermal time constant	t <sub>A</sub>	50	61	70	77	[min]
Operating threshold thermo contact	T <sub>TK</sub>	130	130	130	130	[°C]
<b>electrical data</b>						
Number of poles	PZ	8	8	8	8	8
Circuit of the motor windings		Y	Y	Y	Y	
Torque constant (20°C)	K <sub>M20</sub>	2,36	2,55	2,55	2,64	[Nm/A]
Torque constant (120°C)	K <sub>M120</sub>	2,15	2,32	2,32	2,40	[Nm/A]
Winding resistance(20°C)	R <sub>W20</sub>	2,70	1,13	0,60	0,46	[Ohm]
Winding inductivity(20°C)	L <sub>W</sub>	20,75	7,74	4,20	2,30	[mH]
EMK at 1000 rpm	EMK	143	154	154	159	[V]
Standstill current	I <sub>0M</sub>	5,09	8,39	12,18	14,67	[A]
Peak current	I <sub>SM</sub>	17	28	40	47	[A]

Table 7-15: Technical data SB 145 20 (3AC 400V)

**Technical Data SB 145 30**

 Values are applied to flange-mounted motor with aluminium-plate  
 362,5 x 362,5 x 10 mm

Reference Data	mne- monic	3008	3015	3022	3028	Unit
Standstill torque (standard) -motor with surface ventilation	$M_{OM}$	11	19 34	27	36	[Nm]
Rated speed	$n_N$	3000	3000	3000	3000	[UPM]
fringe motor power	$P_{ECKM}$	3,5	6,1	8,4	11	[kW]
Peak torque(120°C)	$M_{SM}$	37,4	64,4	87,9	115	[Nm]
<b>physical data</b>						
max. mechanical limit rpm	$n_{limit}$	700	700	700	700	[rad/s]
Motor's moment fo inertia	$J_M$	10,5	16	21,5	27	[kgcm <sup>2</sup> ]
Acceleration at $M_{SM}$	$A_{SM}$	39607	44517	44929	46799	[rad/s <sup>2</sup> ]
max.shock (all directions)	S	200	200	200	200	[m/s <sup>2</sup> ]
max. vibration (radial)	$V_R$	200	200	200	200	[m/s <sup>2</sup> ]
max. vibration (axial)	$V_A$	40	40	40	40	[m/s <sup>2</sup> ]
Mass	m	10	14	18	22	[kg]
run-up time	$t_{bSM}$	7,9	7,1	7,0	6,7	[ms]
<b>thermal data</b>						
thermal time constant	$t_A$	50	61	70	77	[min]
Operating thereshold thermo contact	$T_{TK}$	130	130	130	130	[°C]
<b>electrical data</b>						
Number of poles	PZ	8	8	8	8	
Circuit of the motor windings		Y	Y	Y	Y	
Torque constant (20°C)	$K_{M20}$	1,58	1,73	1,73	1,73	[Nm/A]
Torque constant (120°C)	$K_{M120}$	1,44	1,57	1,57	1,57	[Nm/A]
Winding resistance (20°C)	$R_{W20}$	1,17	0,52	0,305	0,185	[Ohm]
Winding inductivity(20°C)	$L_W$	8,77	3,36	1,83	1,22	[mH]
EMK at 1000 rpm	EMK	96	104	104	104	[V]
Standstill current	$I_{OM}$	7,73	12,34	17,02	23,01	[A]
Peak current	$I_{SM}$	26	41	56	73	[A]

Table 7-16: Technial data SB 145 30 (3AC 400V)

### Technical Data SB 145 40

Values are applied to flanged-mounted motor with aluminium-plate  
362,5 x 362,5 x 10 mm

Reference Data	mne- monic	4008	4015	4022	4028	Unit
Standstill torque (standard) - motor with surface ventilation	$M_{0M}$	11	17 33	26	35	[Nm]
Rated speed	$n_N$	4000	4000	4000	4000	[UPM]
fringe motor power	$P_{ECKM}$	4,6	7,3	11	15	[kW]
Peak current (120°C)	$M_{SM}$	36,6	66,3	87,2	111	[Nm]
<b>physical data</b>						
max. mechanical limit rpm	$n_{limit}$	700	700	700	700	[rad/s]
Motor's moment of inertia	$J_M$	10,5	16	21,5	27	[kgcm <sup>2</sup> ]
Acceleration at $M_{SM}$	$A_{SM}$	38816	45688	44591	45518	[rad/s <sup>2</sup> ]
max. shock (all directions)	S	200	200	200	200	[m/s <sup>2</sup> ]
max. vibration (radial)	$V_R$	200	200	200	200	[m/s <sup>2</sup> ]
max. vibration (axial)	$V_A$	40	40	40	40	[m/s <sup>2</sup> ]
Mass	m	10	14	18	22	[kg]
run-up time	$t_{bSM}$	11	9,2	9,4	9,2	[ms]
<b>thermal data</b>						
thermal time constant	$t_A$	57	68	64	68	[min]
Operating threshold thermo contact	$T_{TK}$	130	130	130	130	[°C]
<b>electrical data</b>						
Number of poles	PZ	8	8	8	8	
Circuit of the motor windings		Y	Y	Y	Y	
Torque constant (20°C)	$K_{M20}$	1,09	1,18	1,20	1,20	[Nm/A]
Torque constant (120°C)	$K_{M120}$	0,99	1,07	1,09	1,09	[Nm/A]
Winding resistance (20°C)	$R_{W20}$	0,58	0,30	0,15	0,095	[Ohm]
Winding inductivity(20°C)	$L_W$	4,41	1,67	0,93	0,62	[mH]
EMK at 1000 rpm	EMK	66	71	73	73	[V]
Standstill current	$I_{0M}$	10,98	16,25	24,27	32,11	[A]
Peak current	$I_{SM}$	37	62	80	102	[A]

Table 7-17: Technical Data SB 145 40 (3AC 400V)

**Technical Data SB 205 10**

Values are applied to flange-mounted motor with aluminium-plate  
512,5 x 512,5 x 10 mm

Reference Data	mne- monic	1027	1050	1070	1090	Unit
Standstill torque (standard) -motor with surface ventilation	$M_{0M}$	35	62	85	107	[Nm]
Rated speed	$n_N$	1000	1000	1000	1000	[UPM]
fringe motor power	$P_{ECKM}$	3,7	6,5	8,9	11	[kW]
Peak current (120°C)	$M_{SM}$	127	230	319	412	[Nm]
<b>physical data</b>						
max. mechanical limit rpm	$n_{limit}$	500	500	500	500	[rad/s]
Motor's moment of inertia	$J_M$	50	80	110	140	[kgcm <sup>2</sup> ]
acceleration at $M_{SM}$	$A_{SM}$	32005	36195	36754	37118	[rad/s <sup>2</sup> ]
max. shock (all directions)	S	200	200	200	200	[m/s <sup>2</sup> ]
max. vibration (radial)	$V_R$	200	200	200	200	[m/s <sup>2</sup> ]
max. vibration (axial)	$V_A$	40	40	40	40	[m/s <sup>2</sup> ]
Mass	m	32	44	56	68	[kg]
run-up time	$t_{bSM}$	3,3	2,9	2,8	2,8	[ms]
<b>thermal data</b>						
thermal time constant	$t_A$	116	126	142	150	[min]
Operating threshold thermo contact	$T_{TK}$	130	130	130	130	[°C]
<b>electrical data</b>						
Number of poles	PZ	8	8	8	8	
Circuit of the motor windings		Y	Y	Y	Y	
Torque constant (20°C)	$K_{M20}$	4,35	4,35	4,49	4,35	[Nm/A]
Torque constant (120°C)	$K_{M120}$	3,96	3,96	4,09	3,96	[Nm/A]
Winding resistance (20°C)	$R_{W20}$	1,66	0,59	0,362	0,235	[Ohm]
Winding inductivity (20°C)	$L_W$	18,35	9,415	6,33	4,51	[mH]
EMK at 1000 rpm	EMK	263	263	271	263	[V]
Standstill current	$I_{0M}$	8,80	15,55	20,85	27,09	[A]
Peak current	$I_{SM}$	32	58	78	104	[A]

Table 7-18: Technical Data SB 205 10 (3AC 400V)

### Technical Data SB 205 20

Values are applied to flanged-mounted motor with aluminium-plate  
512,5 x 512,5 x 10 mm

Reference Data	mne- monic	2027	2050	2070	2090	Unit
Standstill torque (standard) - motor with surface ventilation	M <sub>0M</sub>	35	53	84	106	[Nm]
Rated speed	n <sub>N</sub>	2000	2000	2000	2000	[UPM]
fringe motor power	P <sub>ECKM</sub>	7,3	11	18	22	[kW]
Peak torque(120°C)	M <sub>SM</sub>	111	203	281	362	[Nm]
<b>physical data</b>						
max. mechanical limit rpml	n <sub>Grenz</sub>	500	500	500	500	[rad/s]
Motor's moment fo inertia	J <sub>M</sub>	50	80	110	140	[kgcm <sup>2</sup> ]
Acceleration at M <sub>SM</sub>	A <sub>SM</sub>	27378	30963	31441	31753	[rad/s <sup>2</sup> ]
max. shock (all directions)	S	200	200	200	200	[m/s <sup>2</sup> ]
max. vibration (radial)	V <sub>R</sub>	200	200	200	200	[m/s <sup>2</sup> ]
max. vibration (axial)	V <sub>A</sub>	40	40	40	40	[m/s <sup>2</sup> ]
Mass	m	32	44	56	68	[kg]
run-up time	t <sub>bSM</sub>	7,6	6,8	6,7	6,6	[ms]
<b>thermal data</b>						
thermal time constant	t <sub>A</sub>	116	126	142	150	[min]
Operating thereshold thermo contact	T <sub>TK</sub>	130	130	130	130	[°C]
<b>elektrical data</b>						
Number of poles	PZ	8	8	8	8	
Circuit ot the motor windings		Y	Y	Y	Y	
Torque constant (20°C)	K <sub>M20</sub>	2,31	2,45	2,45	2,18	[Nm/A]
Torque constant (120°C)	K <sub>M120</sub>	2,10	2,23	2,23	1,98	[Nm/A]
Winding resistance ( 20°C)	R <sub>W20</sub>	0,465	0,250	0,110	0,060	[Ohm]
Winding inductivity (20°C)	L <sub>W</sub>	4,66	2,61	1,74	1,13	[mH]
EMK at 1000 rpm	EMK	140	148	148	132	[V]
Standstill current	I <sub>0M</sub>	16,61	23,89	37,82	53,60	[A]
Peak current	I <sub>SM</sub>	53	91	126	183	[A]

Table 7-19: Technical Data SB 205 20 (3AC 400V)

**Technical Data SB 205 30**

 Values are applied to flange-mounted motor with aluminium-plate  
 512,5 x 512,5 x 10 mm

Reference Data	mne- monic	3027	3050	3070	3090	Unit
Standstill torque (standard) -motor with surface ventilation	$M_{0M}$	35	52 84	83	90 145	[Nm]
Rated speed	$n_N$	3000	3000	3000	3000	[UPM]
fringe motor power	$P_{ECKM}$	11	16	26	28	[kW]
Peak torque(120°C)	$M_{SM}$	112	201	281	361	[Nm]
<b>physical data</b>						
max. mechanical limit rpm	$n_{limit}$	500	500	500	500	[rad/s]
Motor's moment of inertia	$J_M$	50	80	110	140	[kgcm <sup>2</sup> ]
Acceleration at $M_{SM}$	$A_{SM}$	27378	30963	31441	31753	[rad/s <sup>2</sup> ]
max. shock (all directions)	S	200	200	200	200	[m/s <sup>2</sup> ]
max. vibration (radial)	$V_R$	200	200	200	200	[m/s <sup>2</sup> ]
max. vibration (axial)	$V_A$	40	40	40	40	[m/s <sup>2</sup> ]
Mass	m	32	44	56	68	[kg]
run-up time	$t_{bSM}$	11	10	10	9,9	[ms]
<b>thermal data</b>						
thermal time constant	$t_A$	116	126	142	150	[min]
Operating threshold thermo contact	$T_{TK}$	130	130	130	130	[°C]
<b>electrical data</b>						
Number of poles	PZ	8	8	8	8	
Circuit of the motor windings		Y	Y	Y	Y	
Torque constant (20°C)	$K_{M20}$	1,5	1,63	1,63	1,63	[Nm/A]
Torque constant (120°C)	$K_{M120}$	1,37	1,48	1,48	1,48	[Nm/A]
Winding resistance (20°C)	$R_{W20}$	0,195	0,115	0,050	0,046	[Ohm]
Winding inductivity (20°C)	$L_W$	1,74	0,96	0,80	0,64	[mH]
EMK at 1000 rpm	EMK	90	99	99	99	[V]
Standstill current	$I_{0M}$	25,65	35,23	56,09	61,22	[A]
Peak current	$I_{SM}$	82	136	190	244	[A]

Table 7-20: Technical Data SB 205 30 (3AC 400V)

### 7.1.9 Torque-speed characteristics

The torque-speed characteristics depict the following developments:

- admissible permanent torque (operating mode S1)
- peak torque at mains voltage = 230 V 3 AC
- peak torque at mains voltage = 380 V 3 AC
- peak torque at mains voltage = 400 V 3 AC
- peak torque at mains voltage = 480 V 3 AC

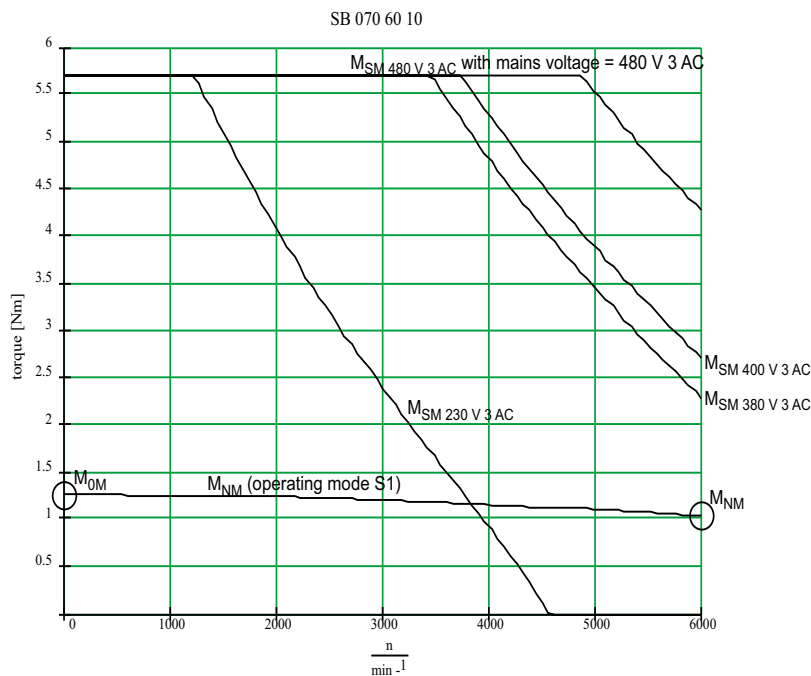

Fig. 7-5: Torque-speed characteristics

The characteristics refer to an ambient temperature of 40 °C and a casing overtemperature of 60 °C.



#### NOTE

With a single-phase mains connection (230 V) the characteristics of „ $M_{SM}$  230 V 3 AC“ move approx. 20% to the left due to the lower DC-circuit voltage.



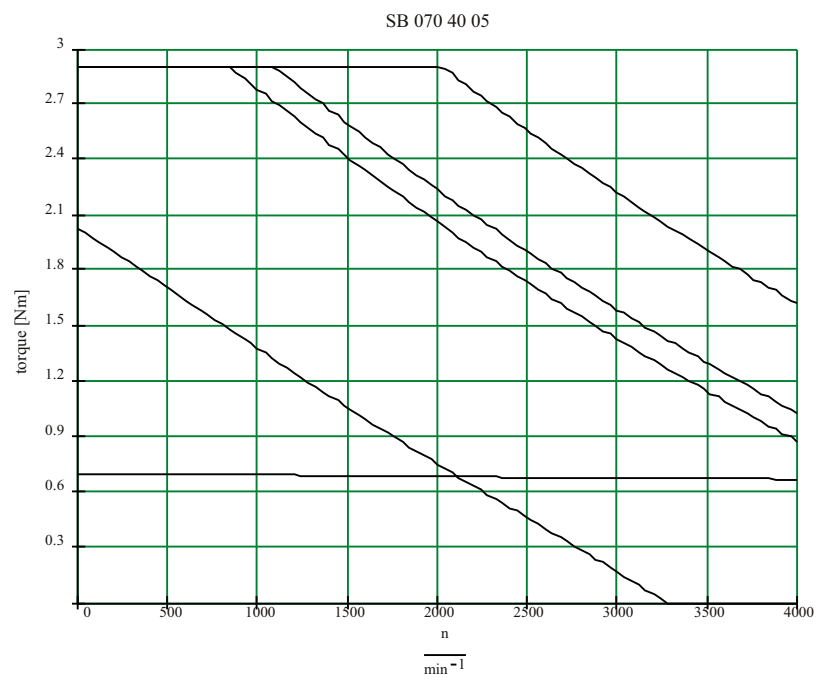
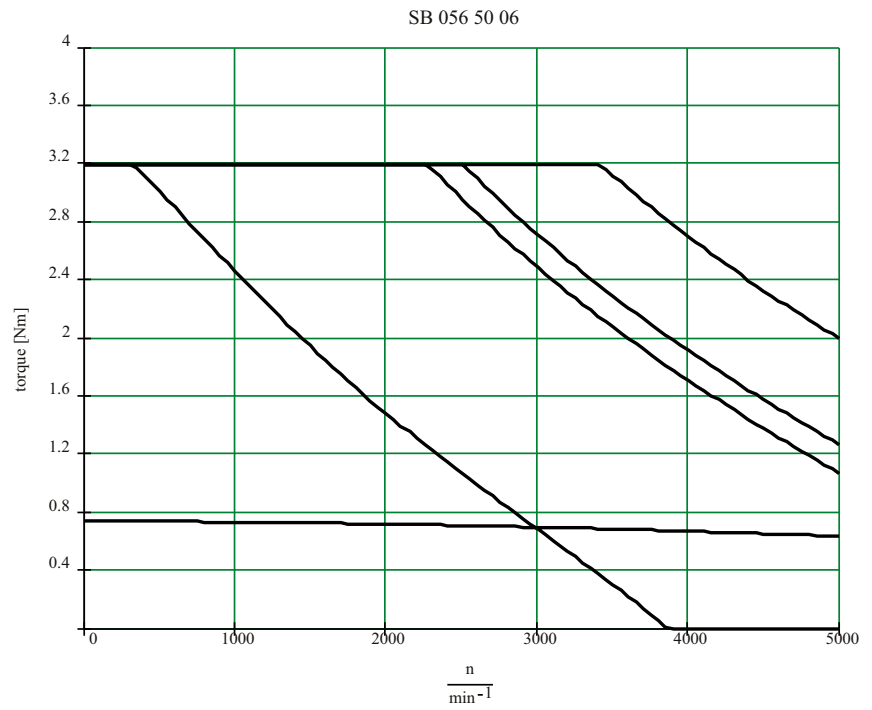

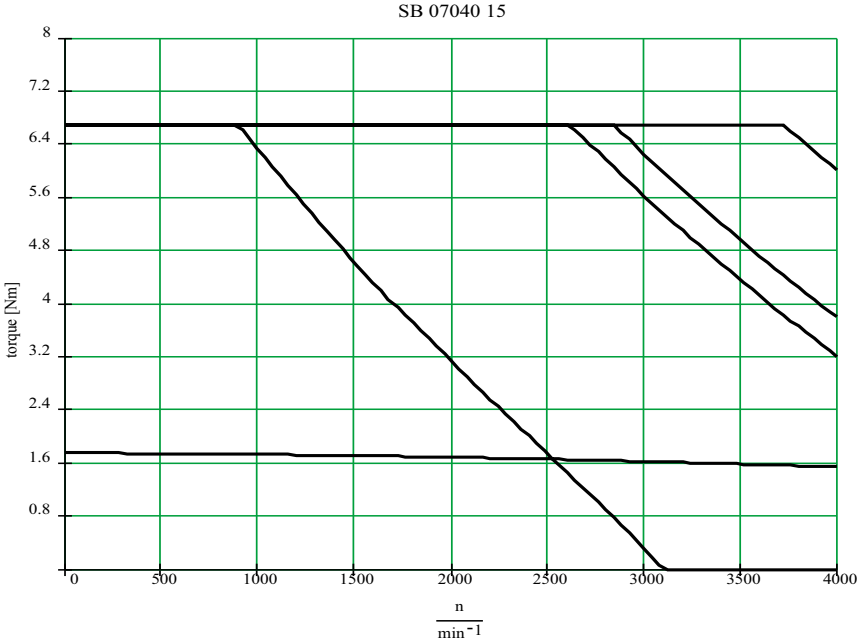
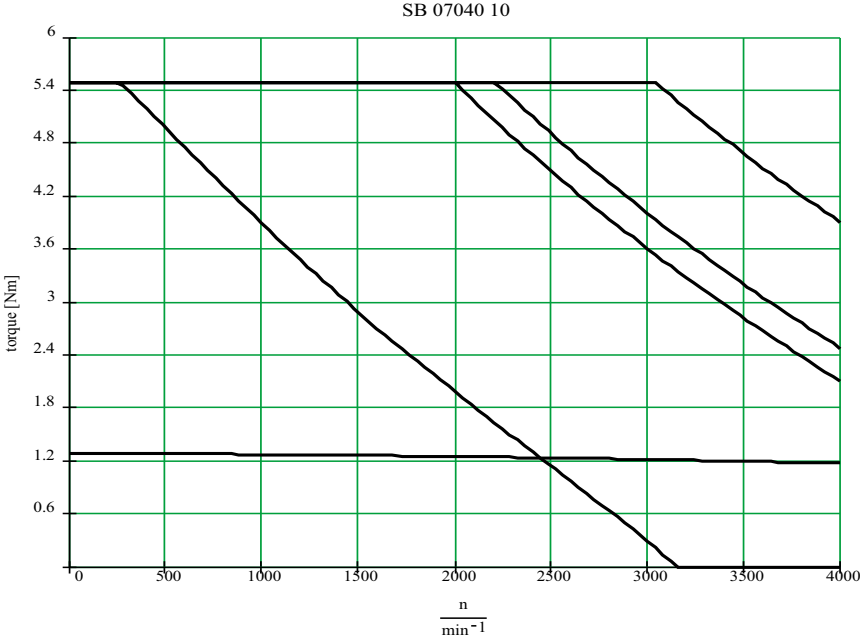

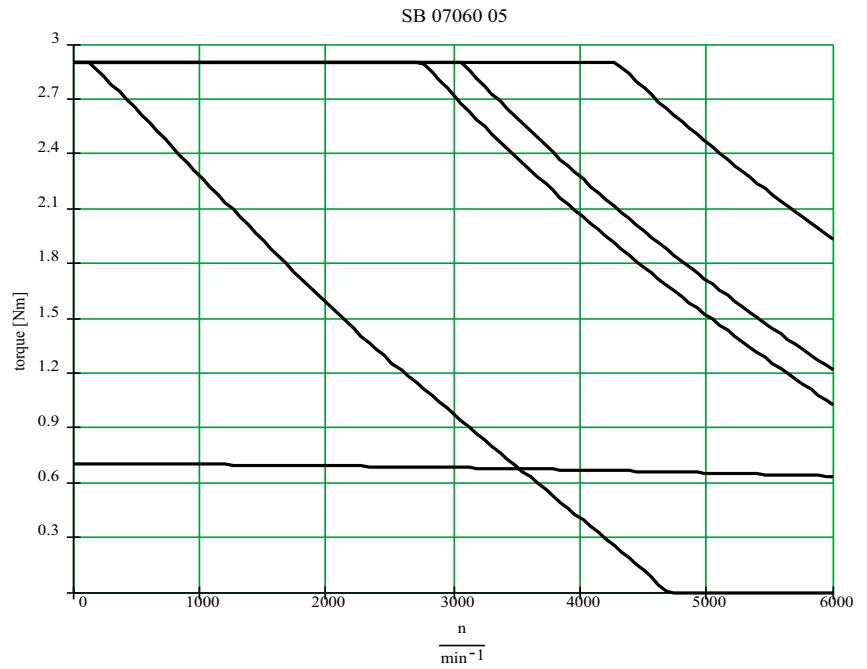
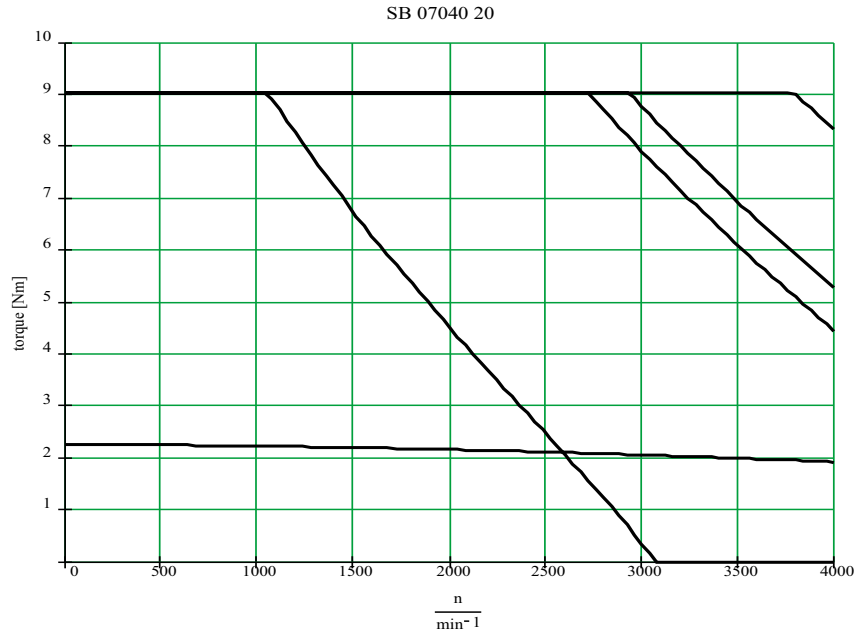

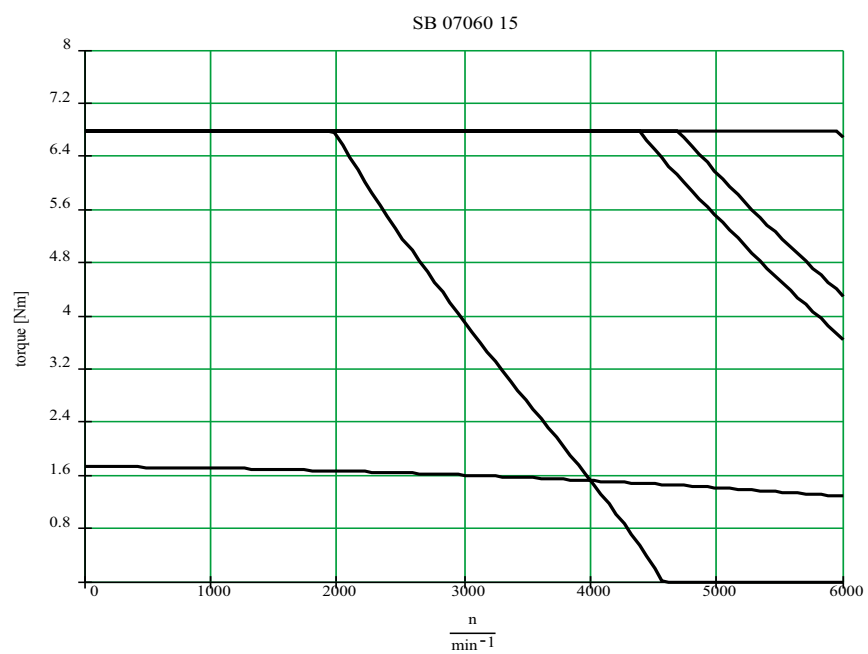
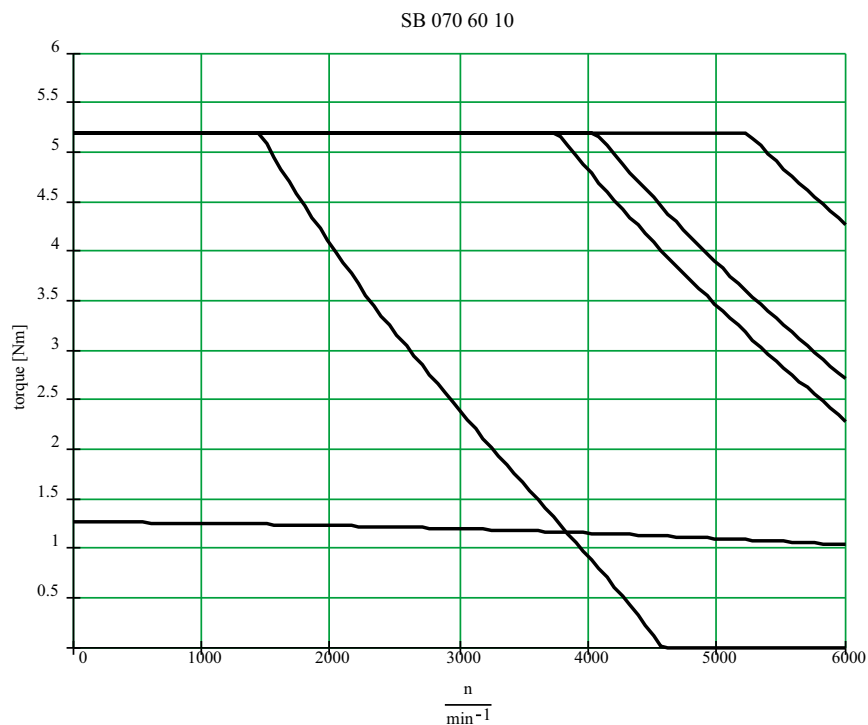

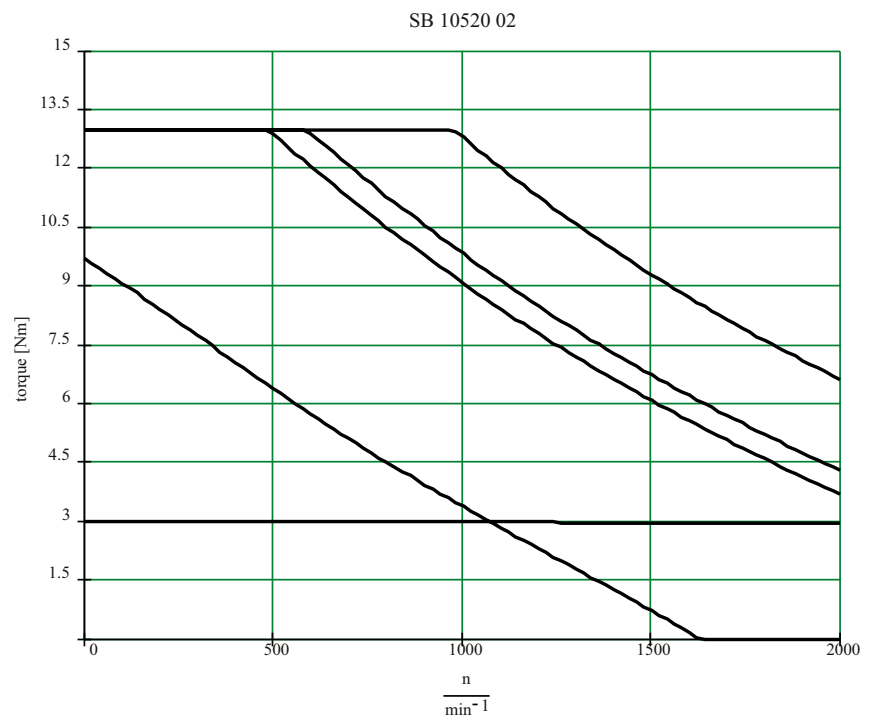
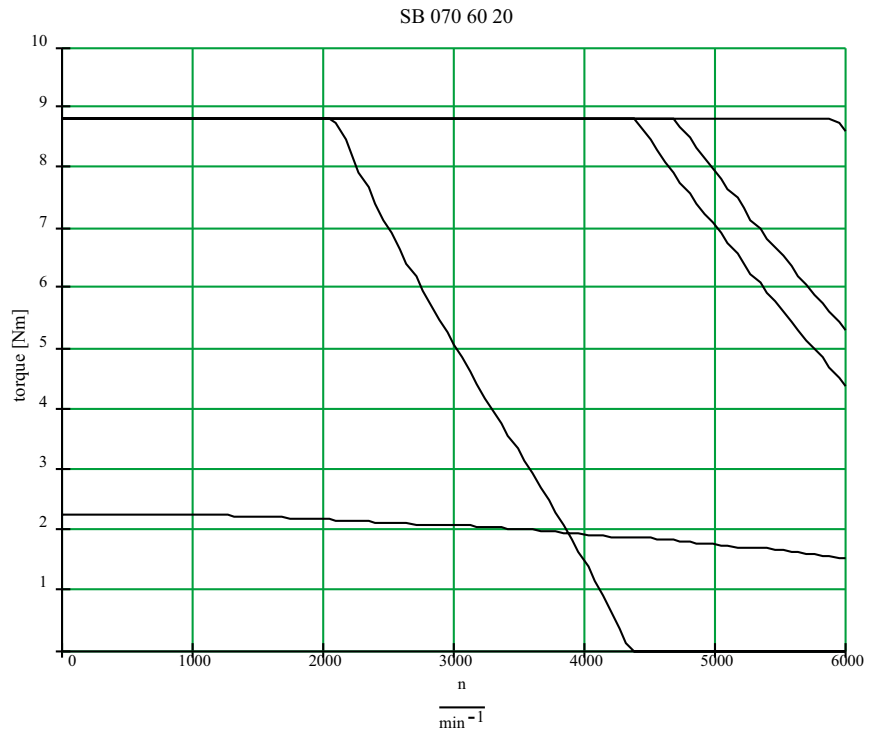

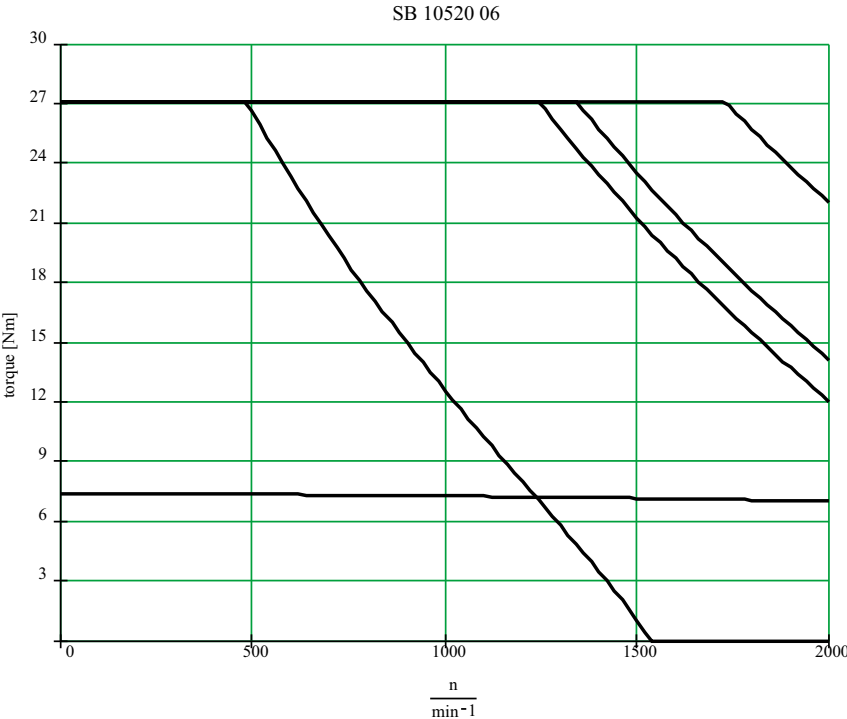
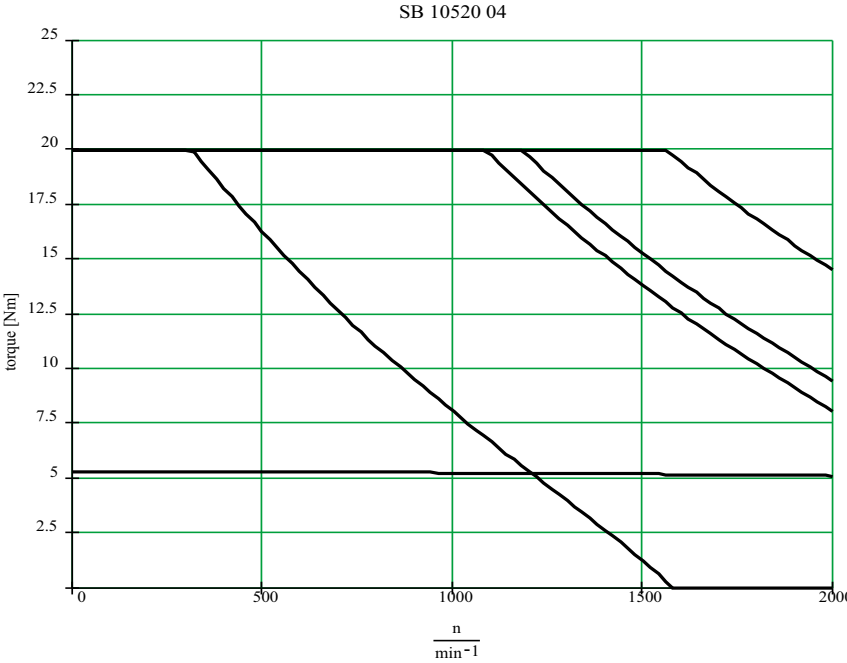

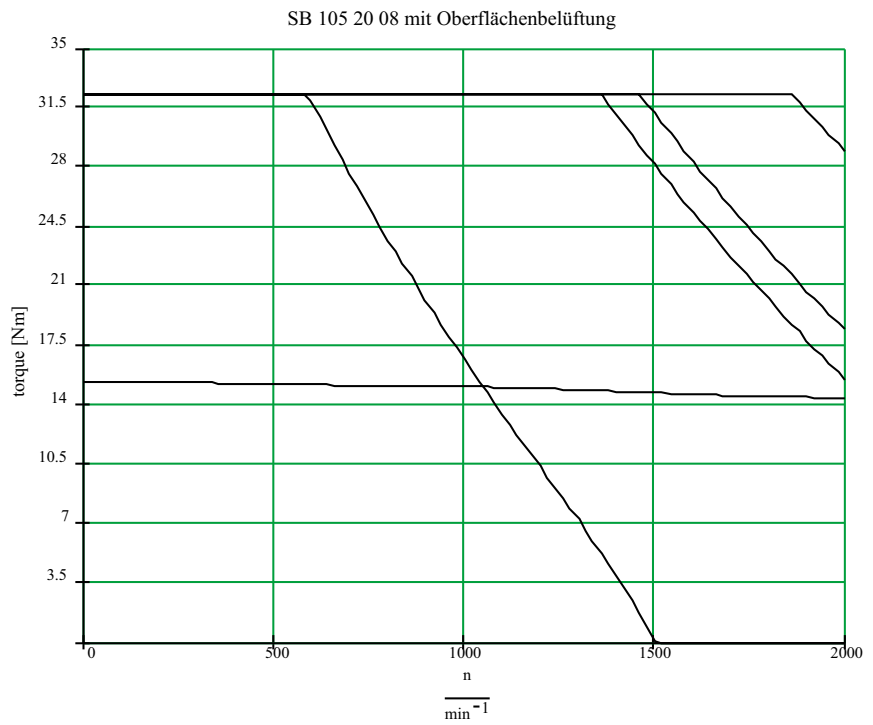
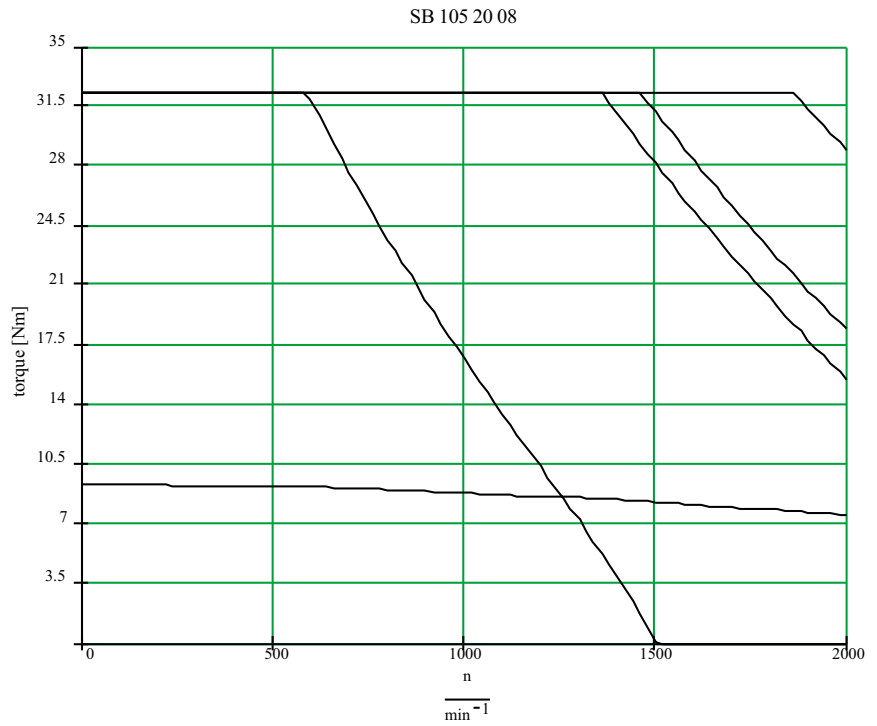

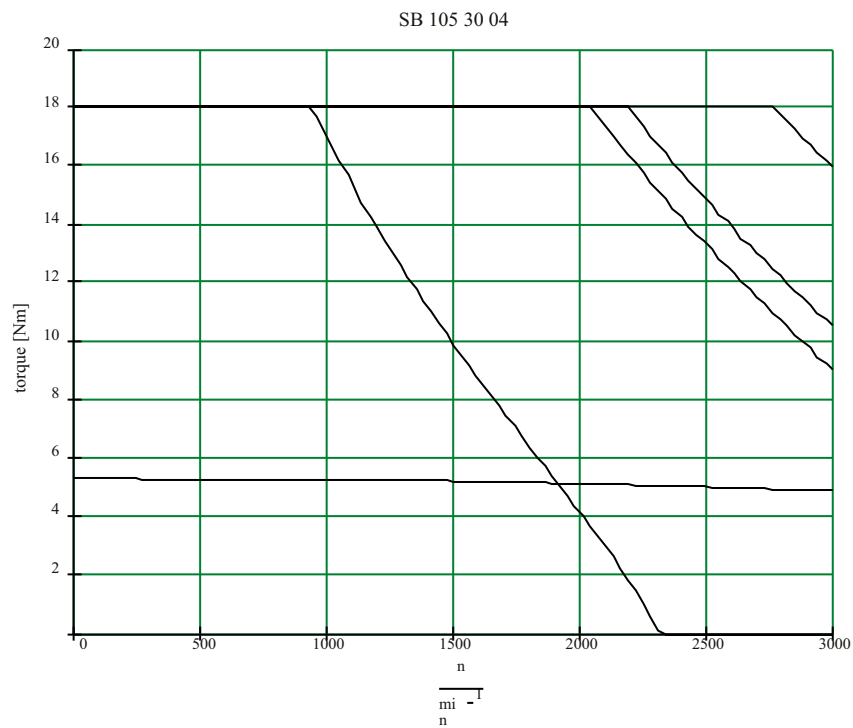
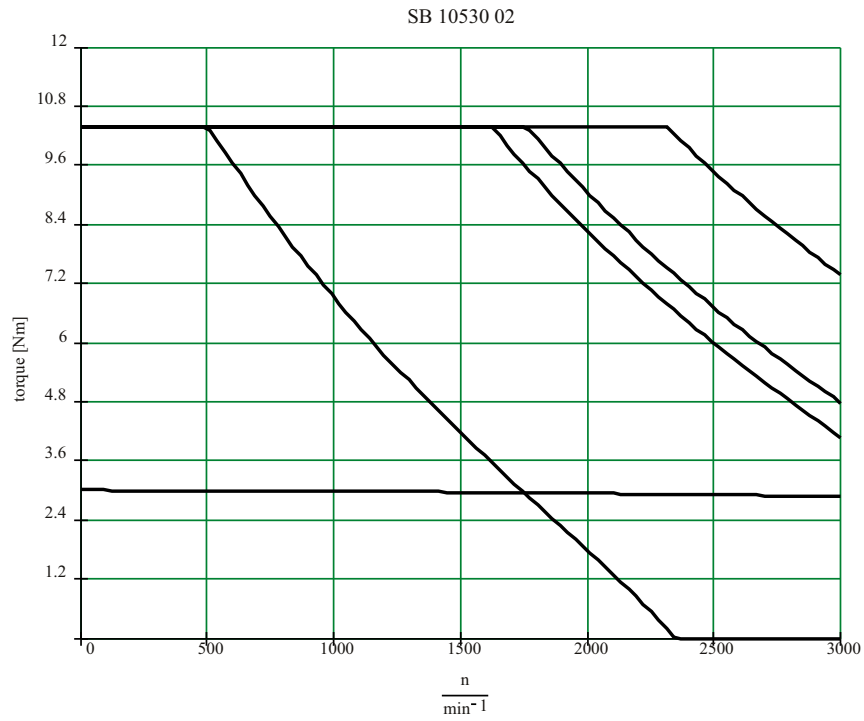



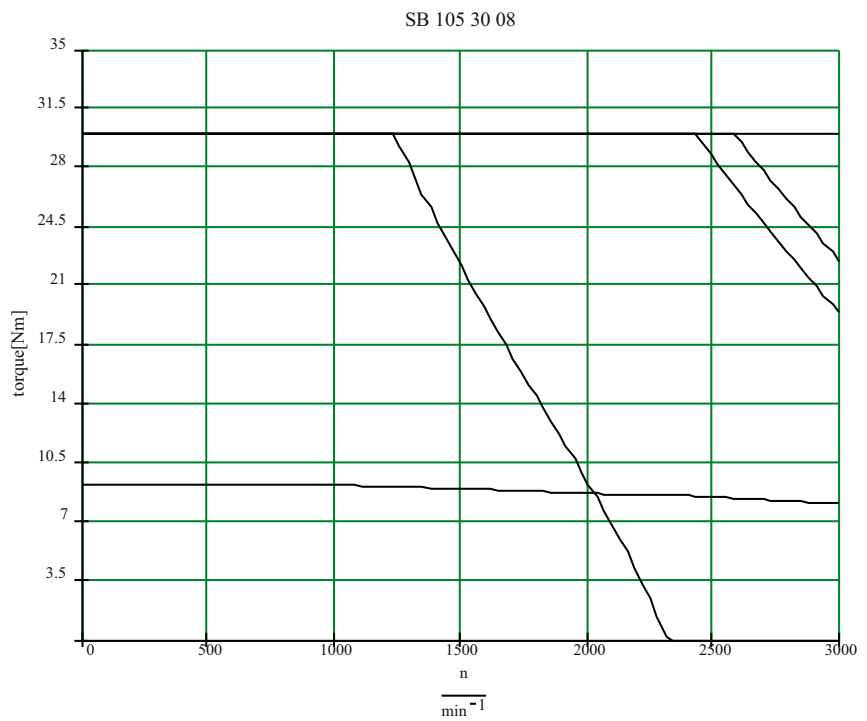
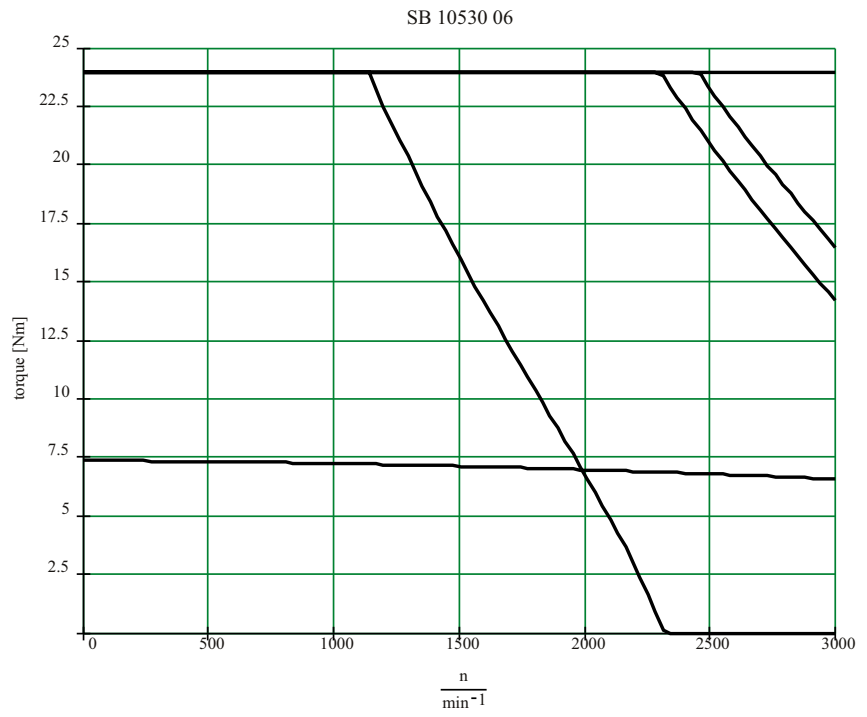

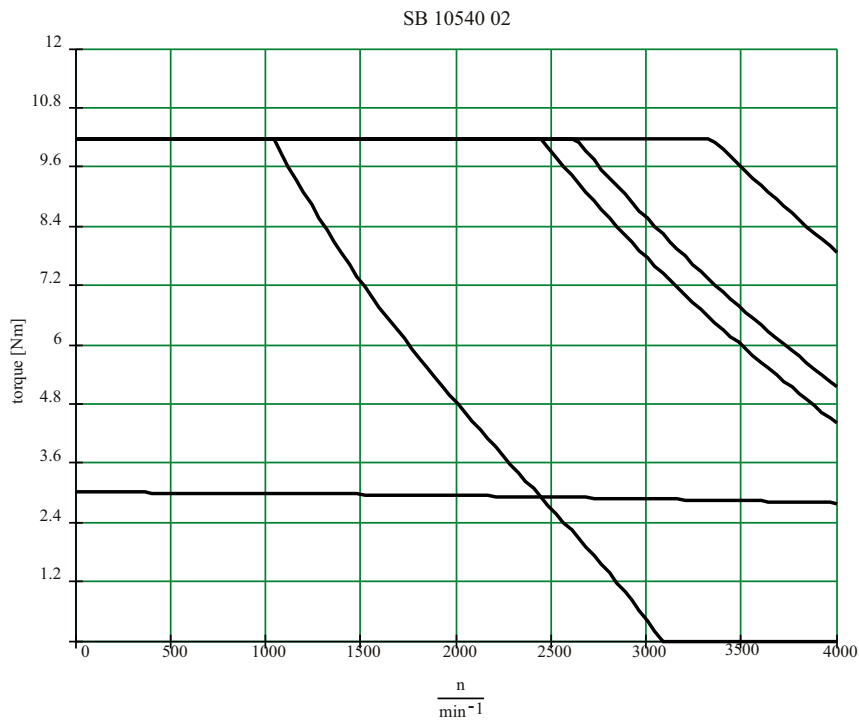
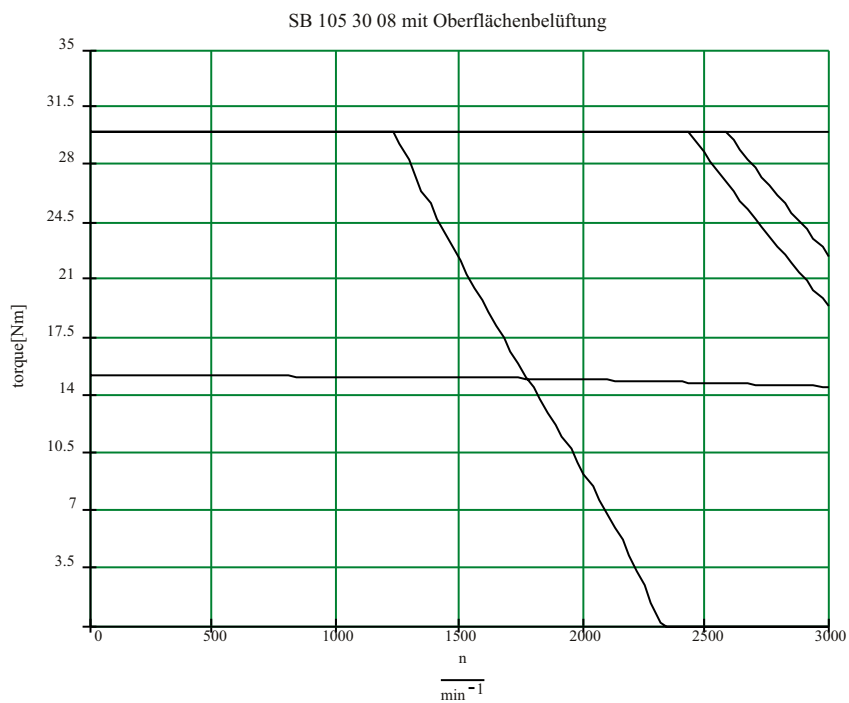

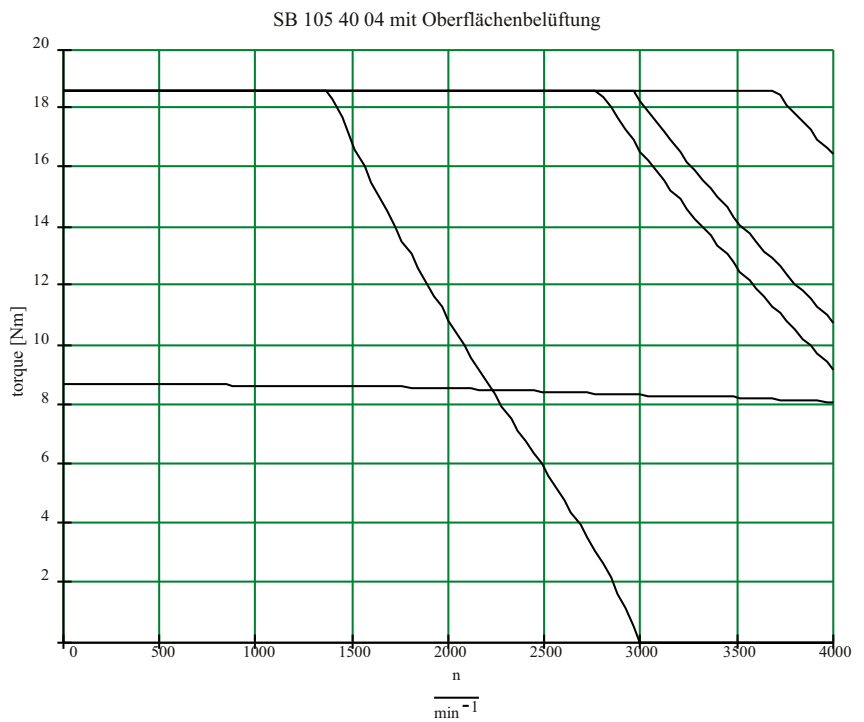
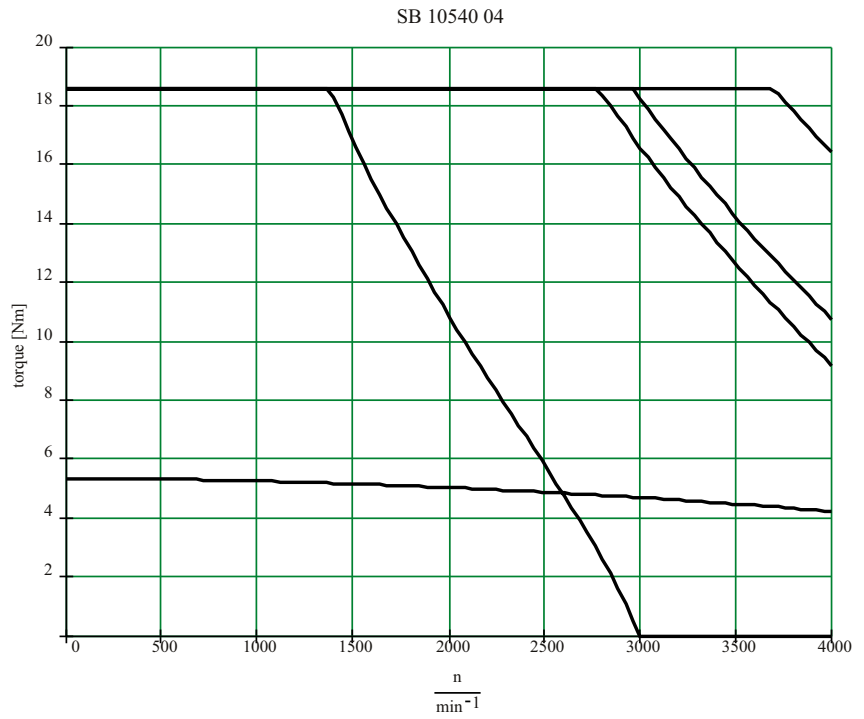

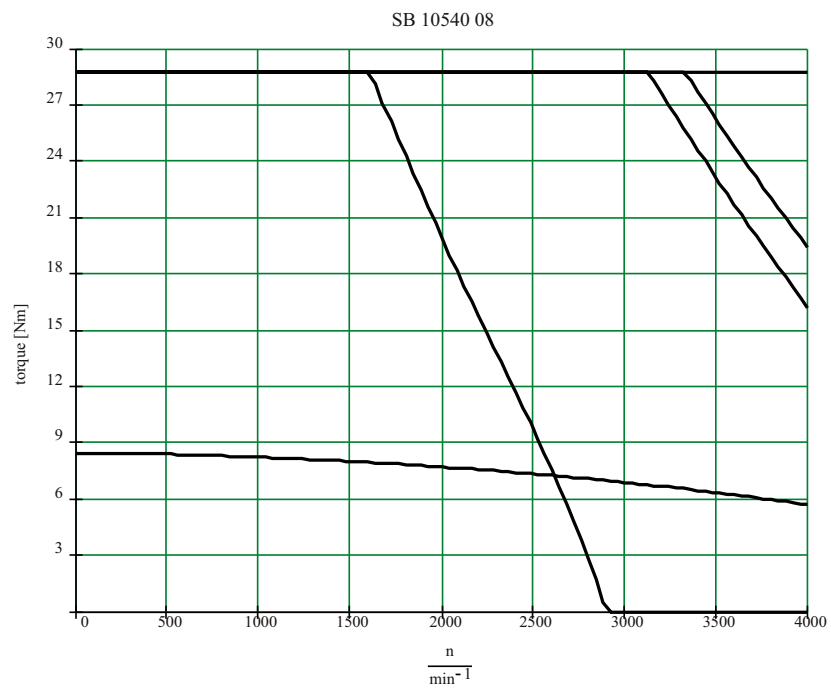
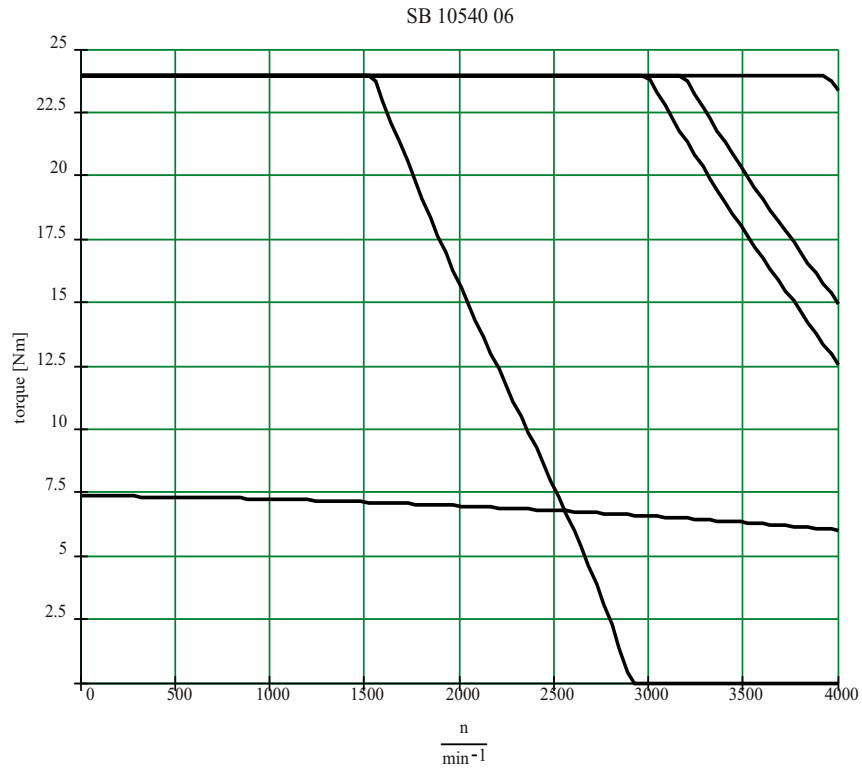

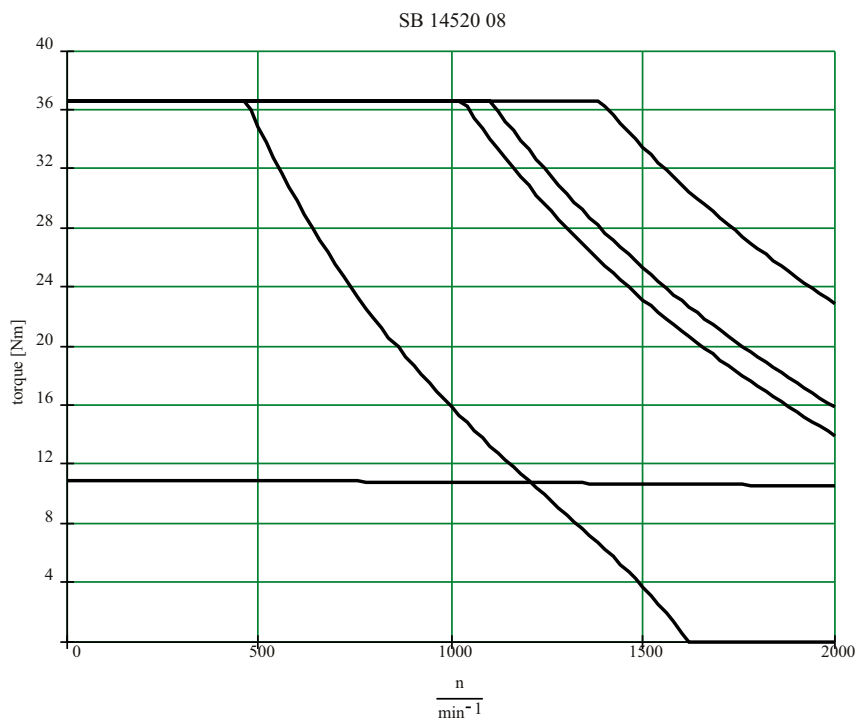
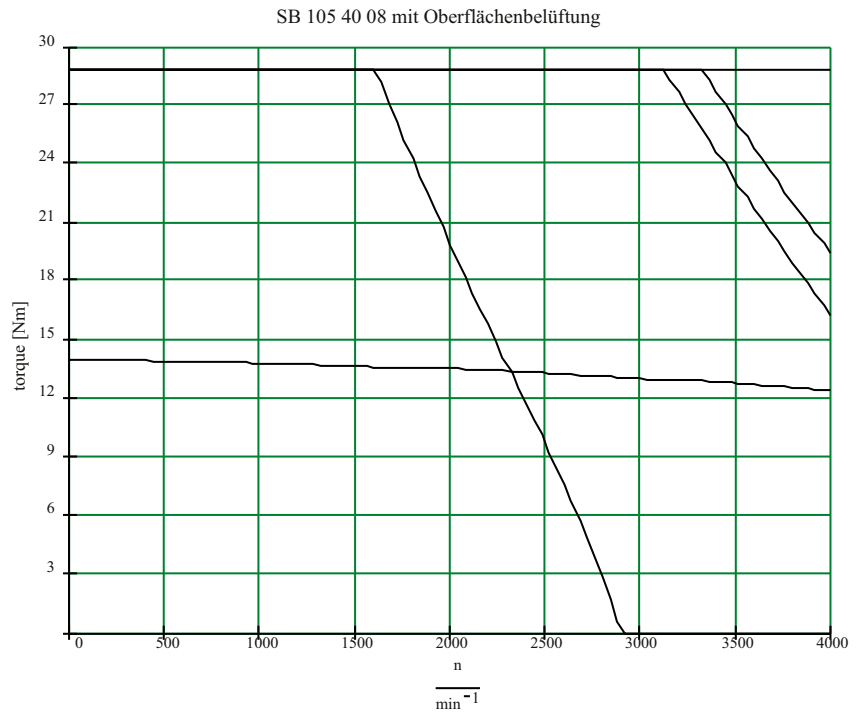

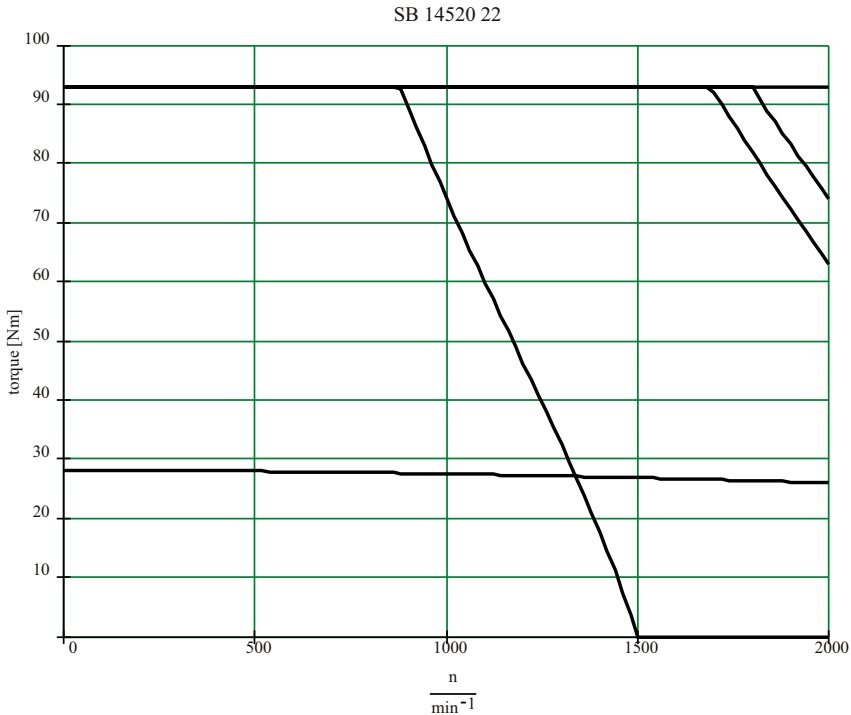
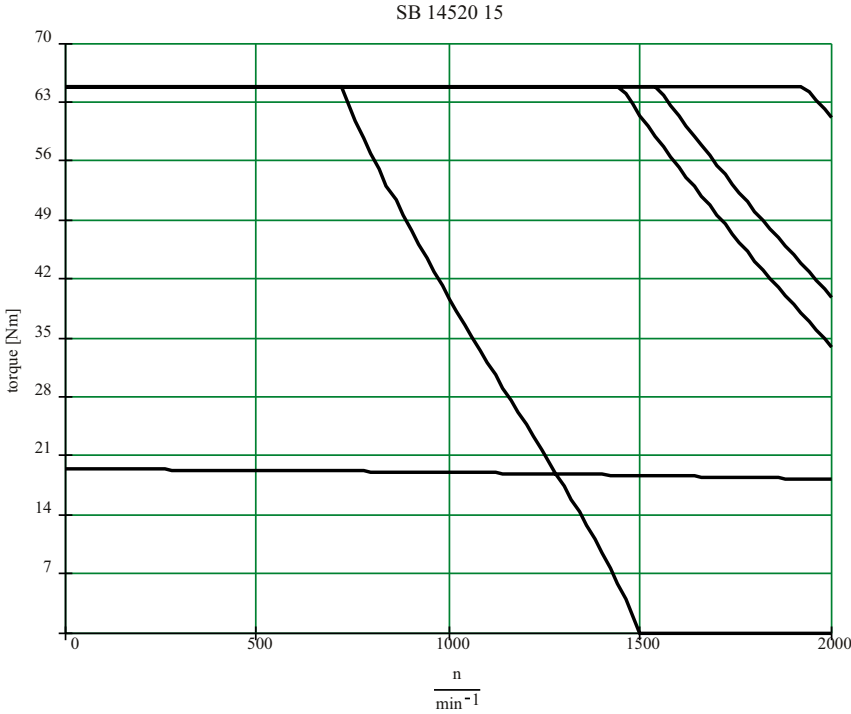

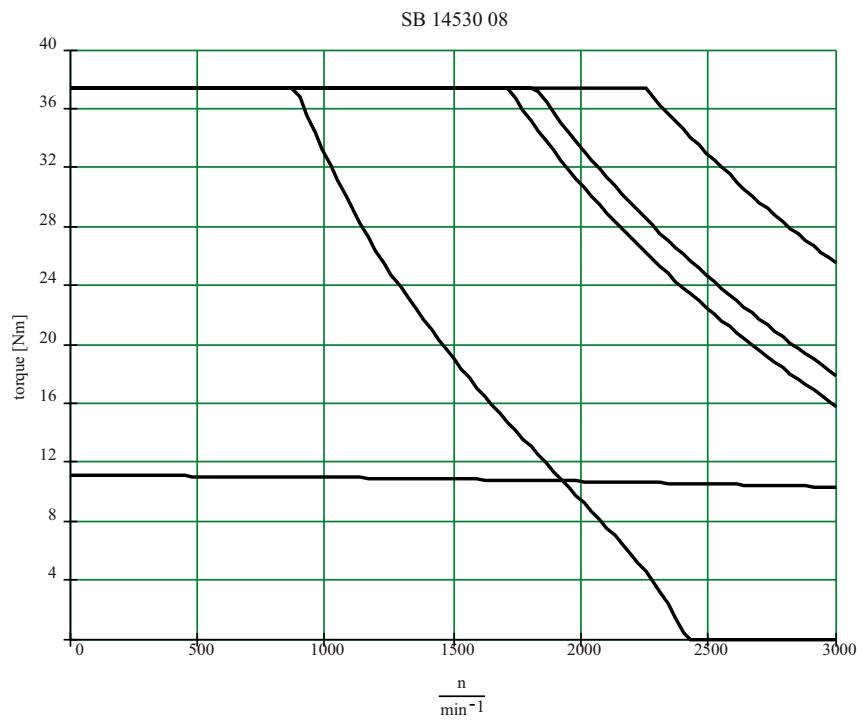
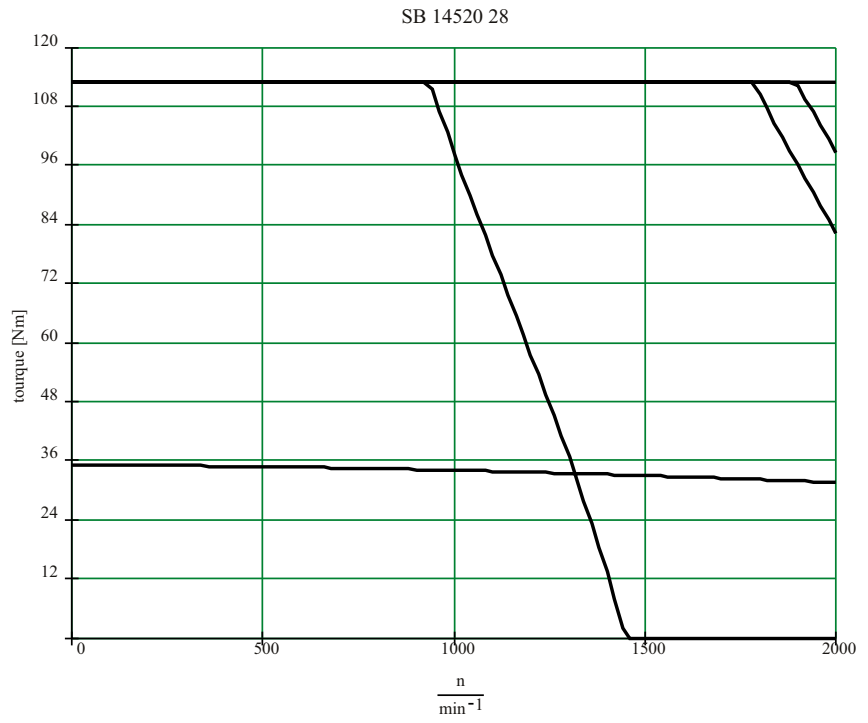

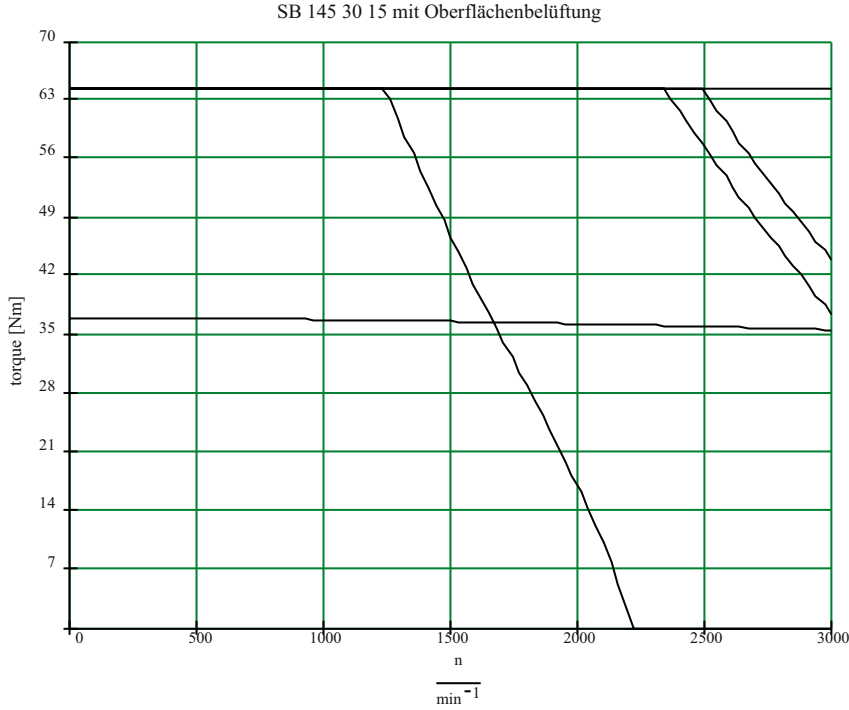
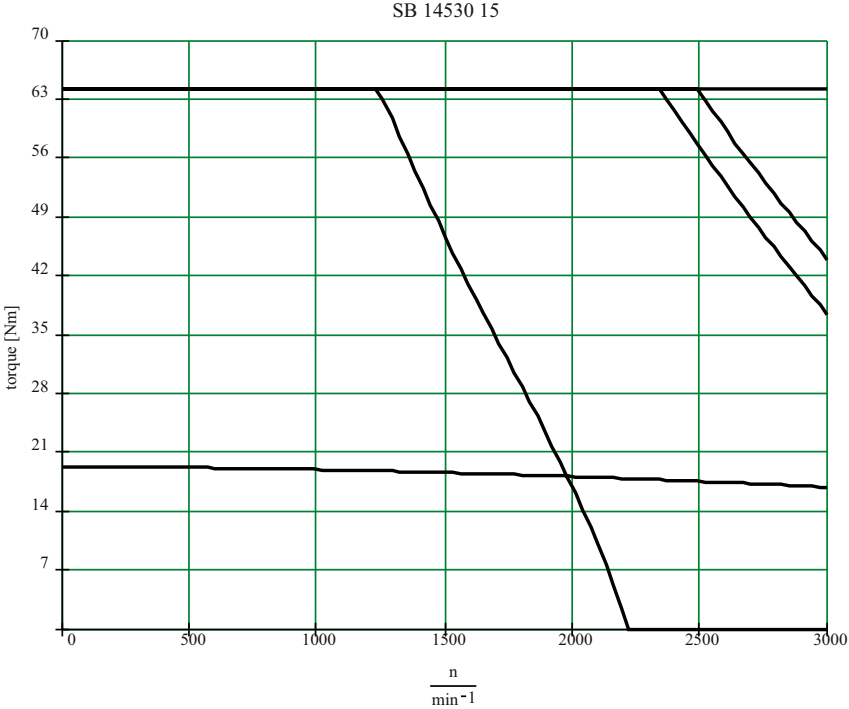



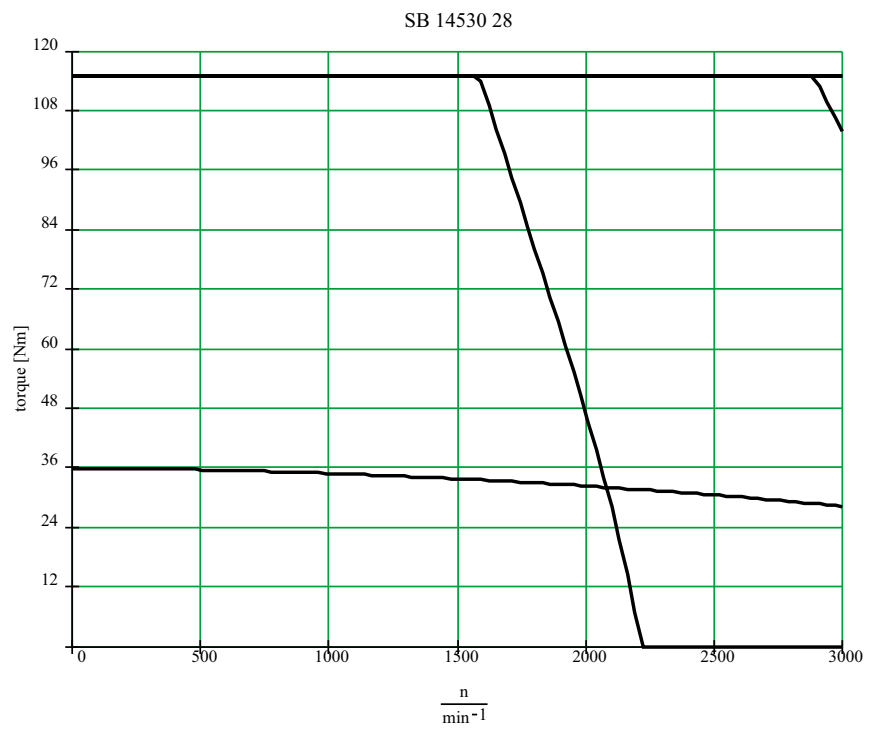
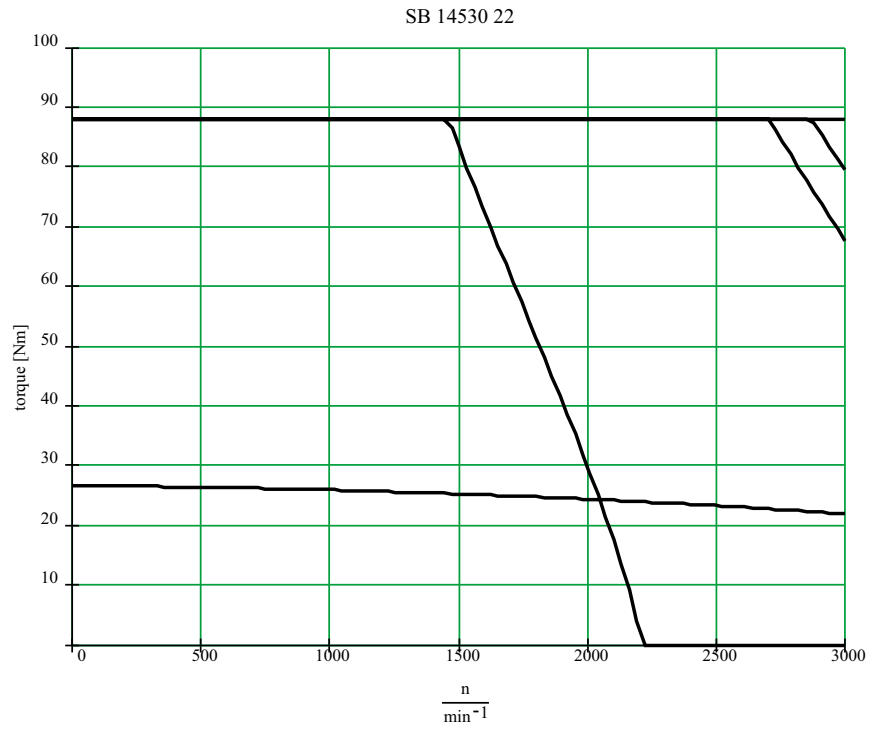

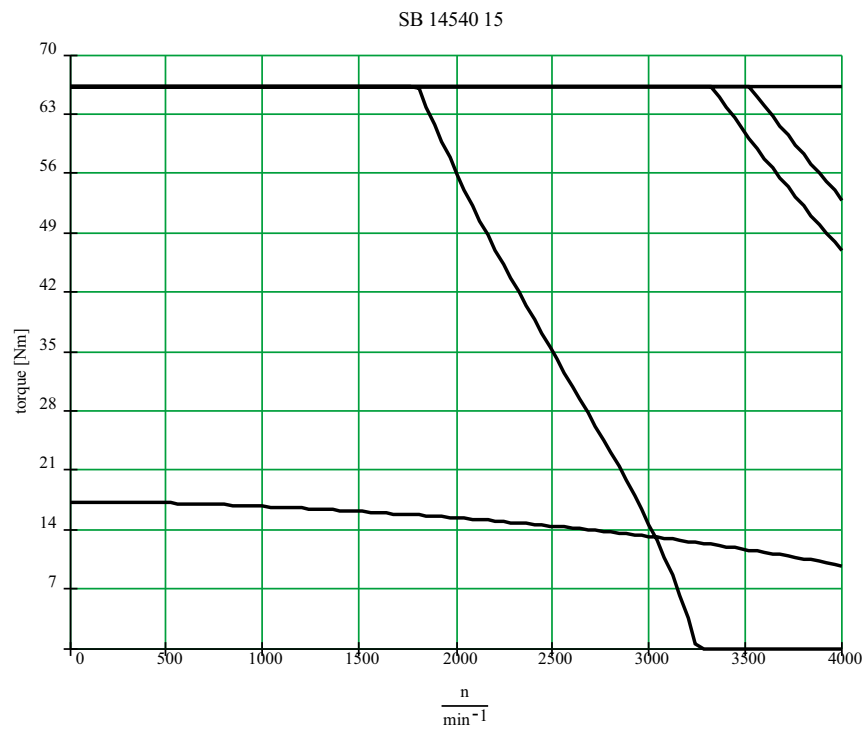
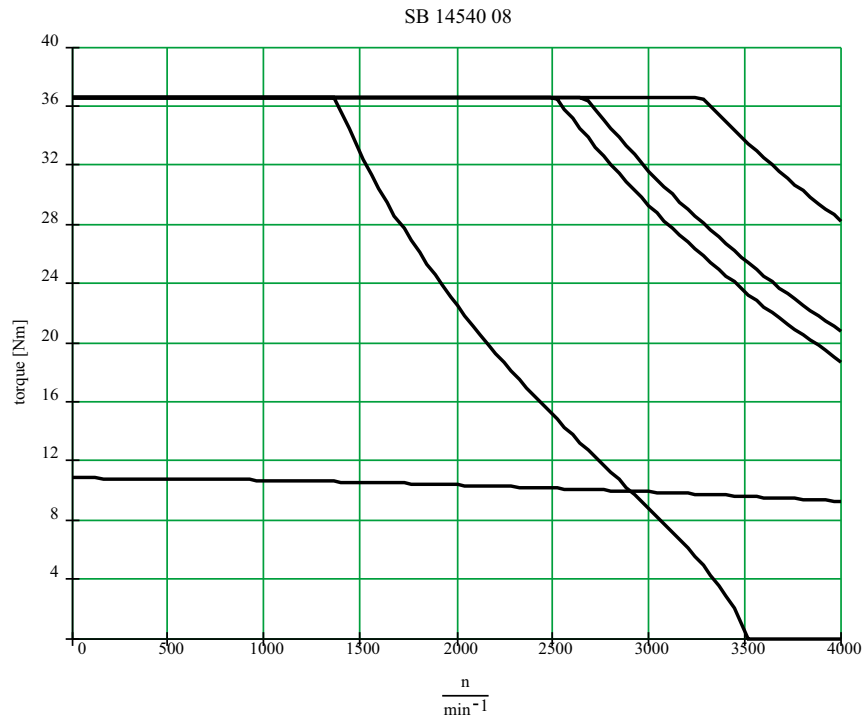

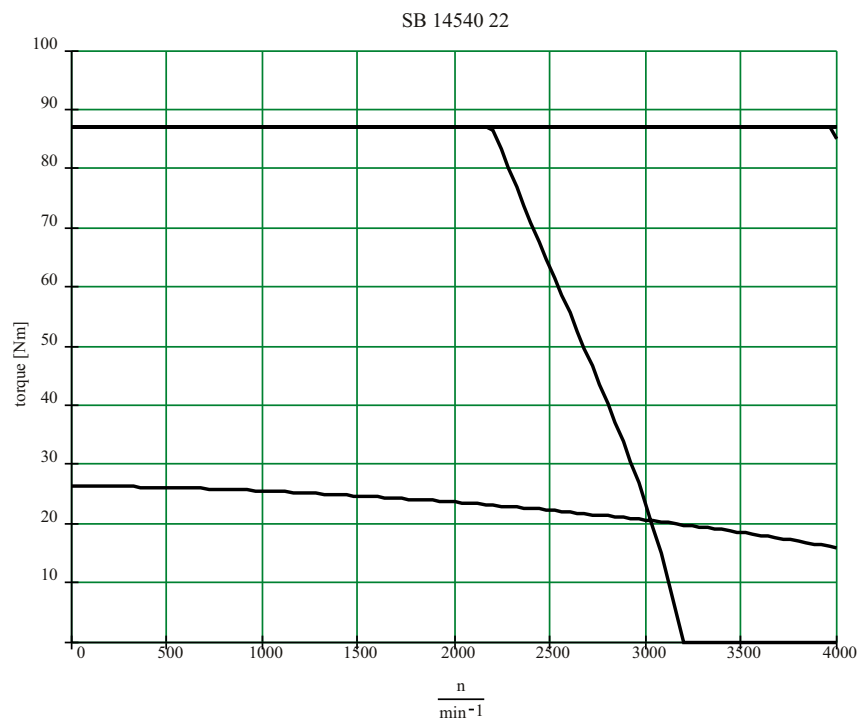
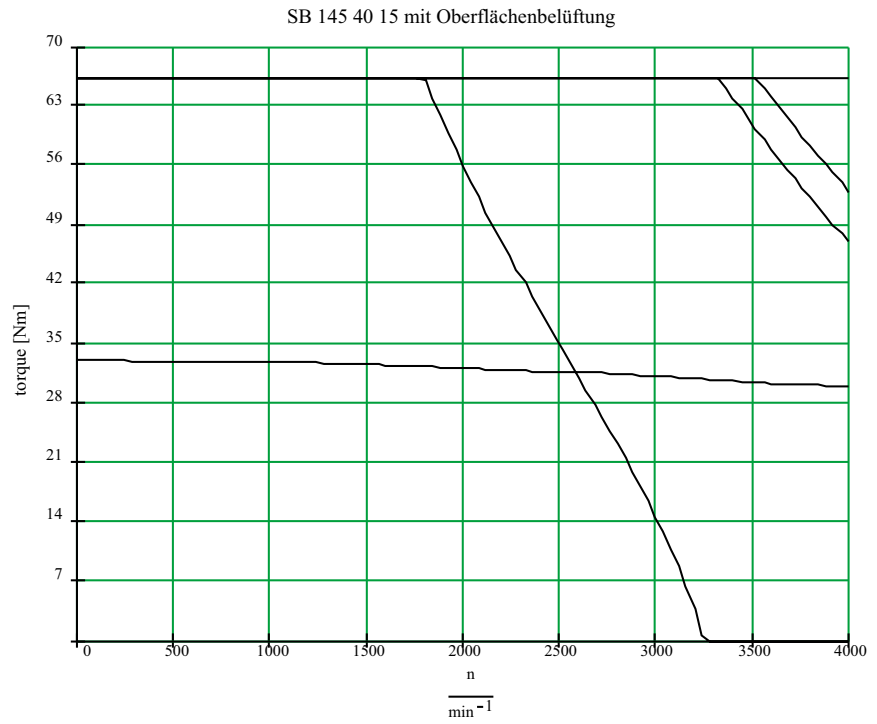

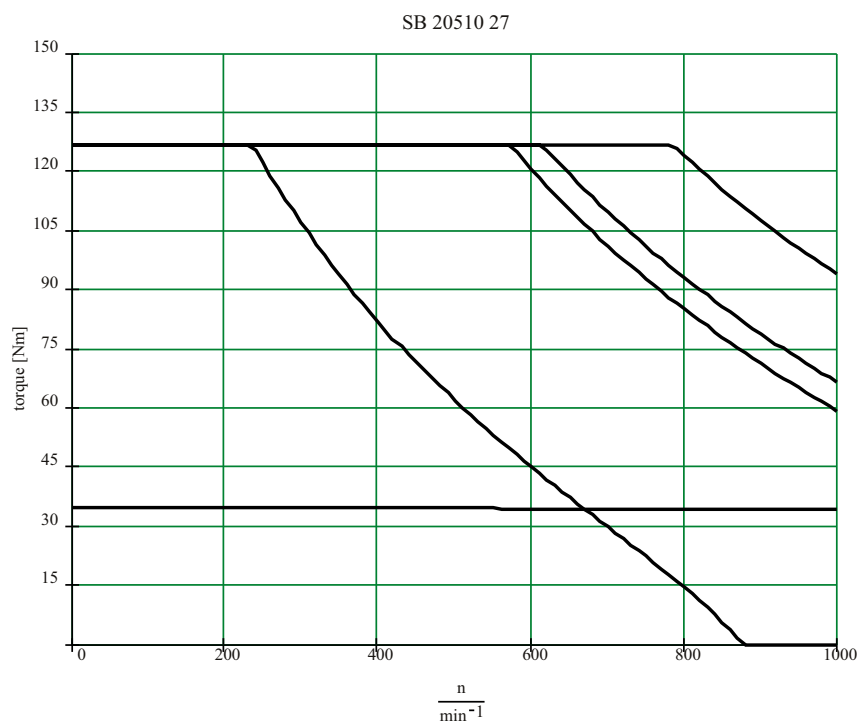
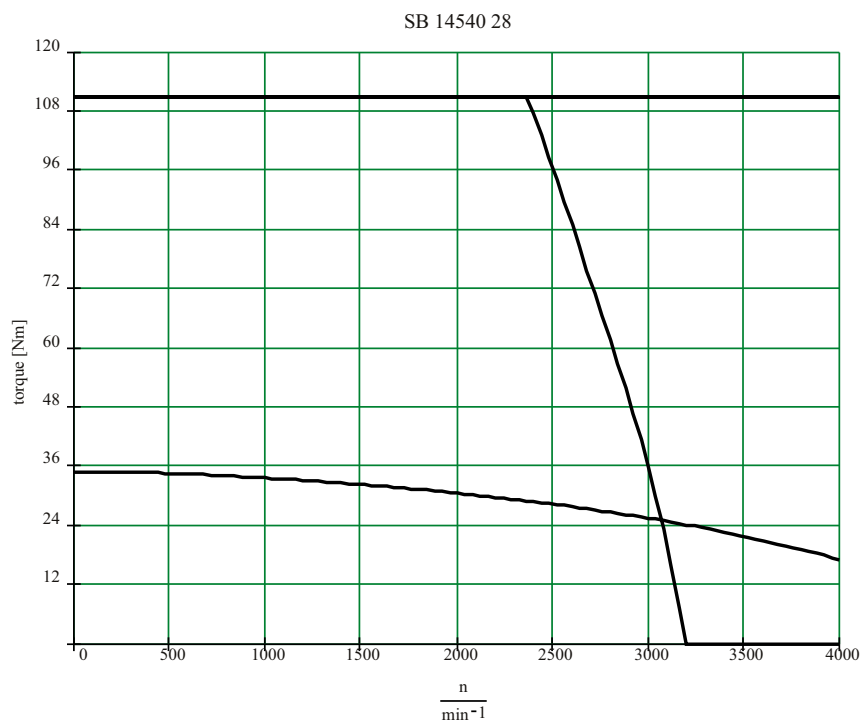

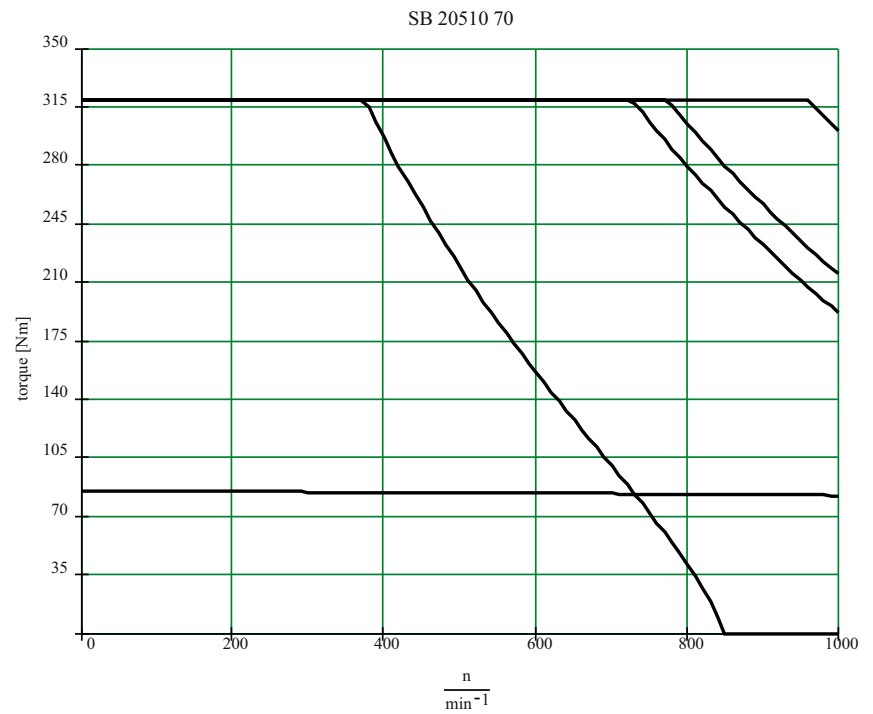
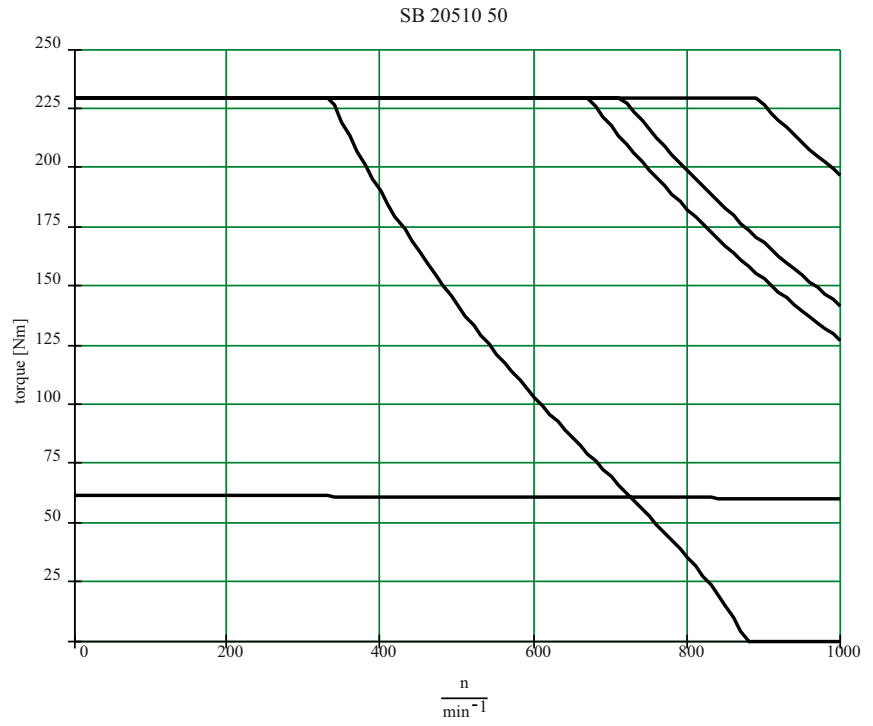

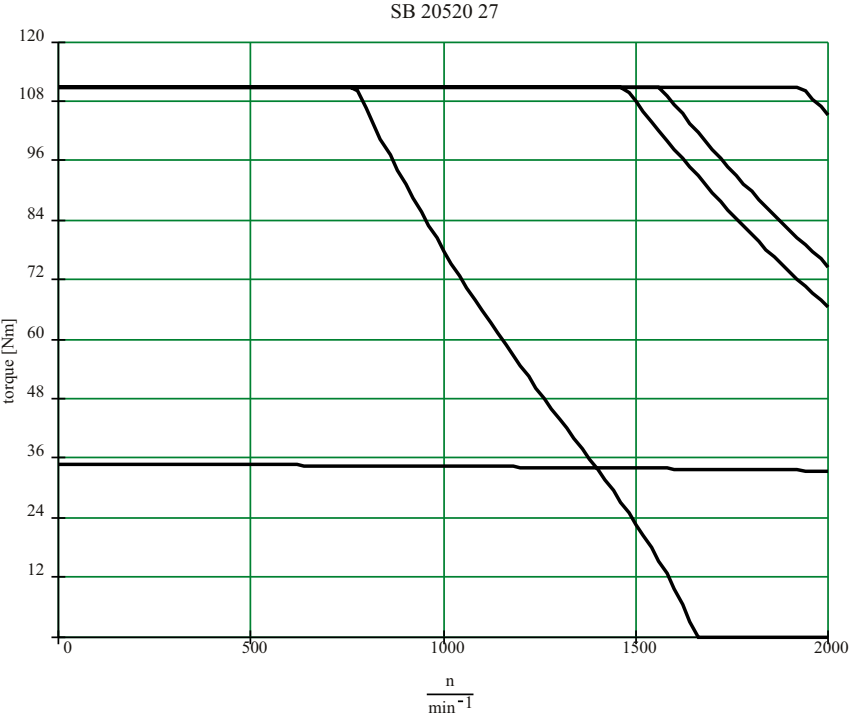
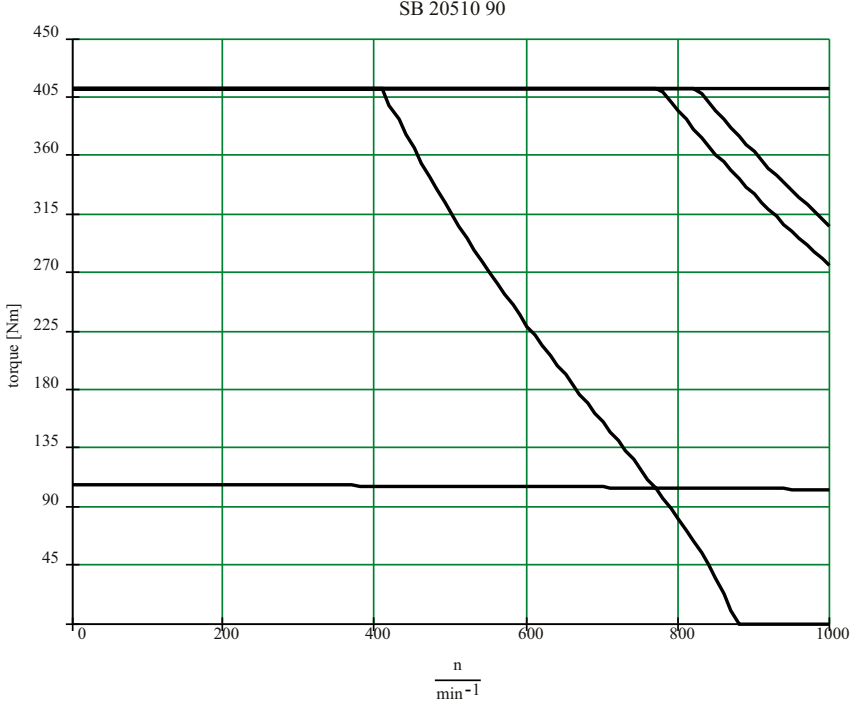

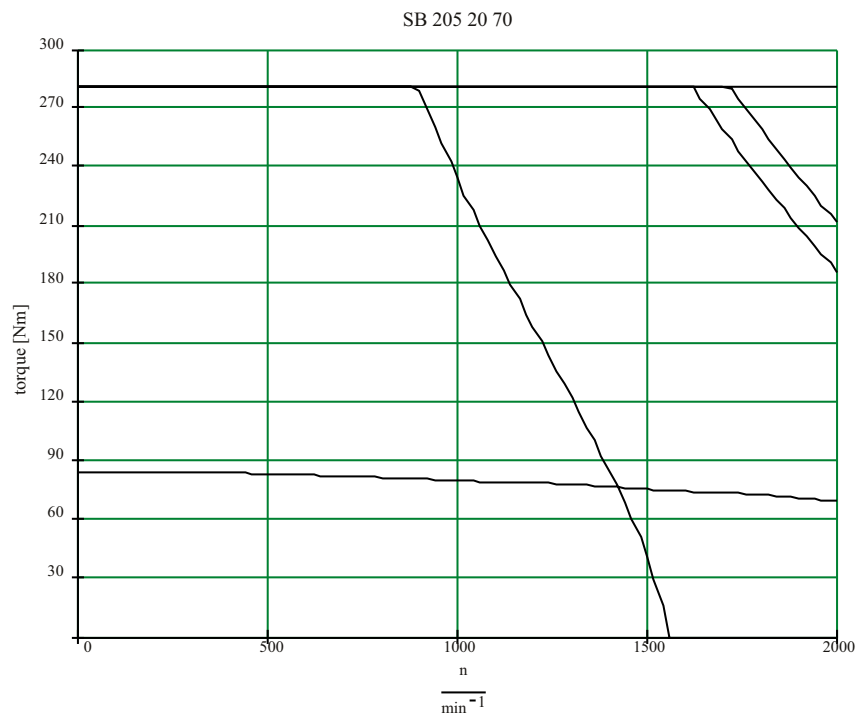
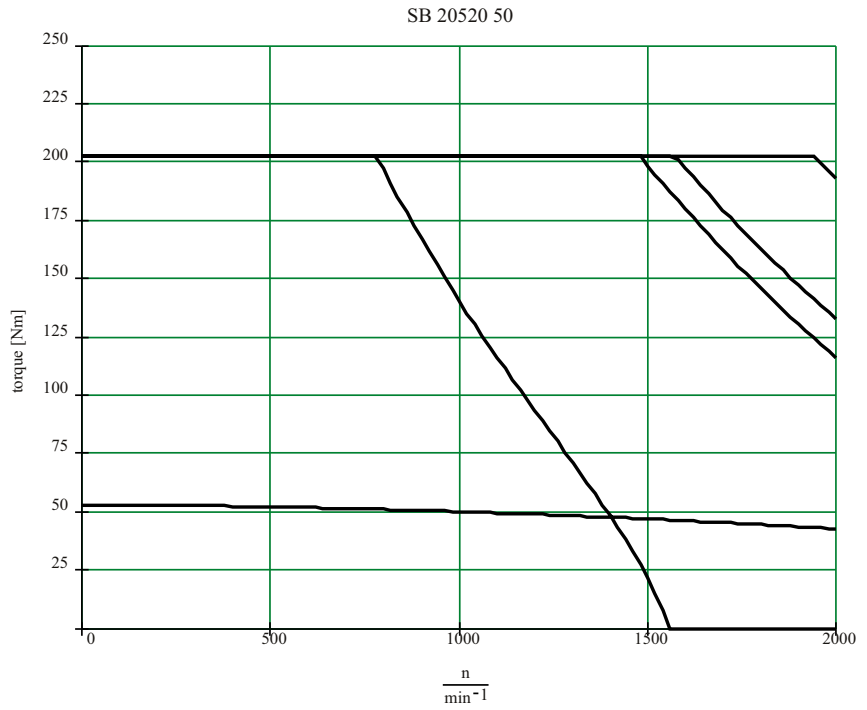

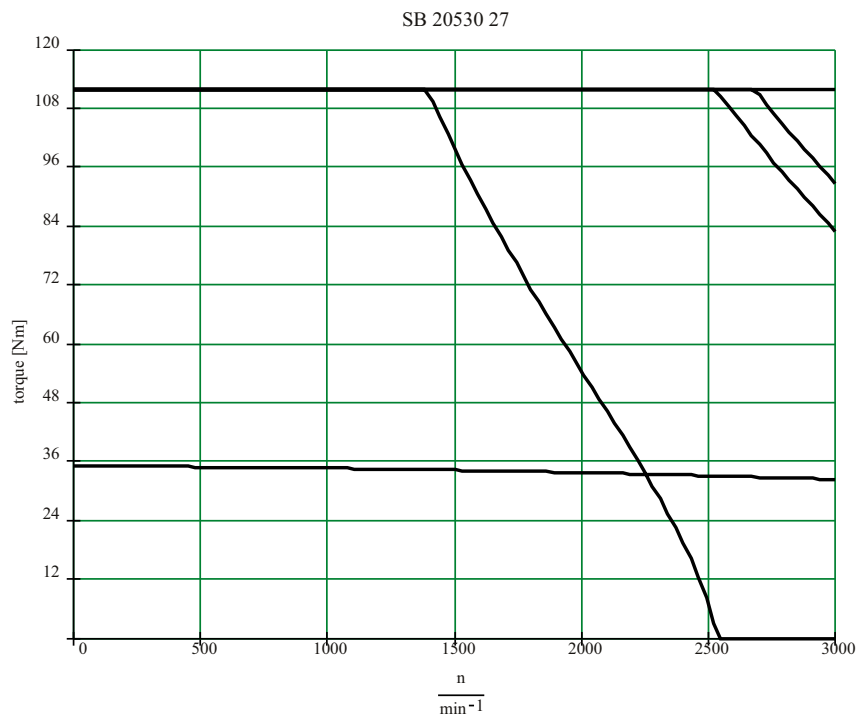
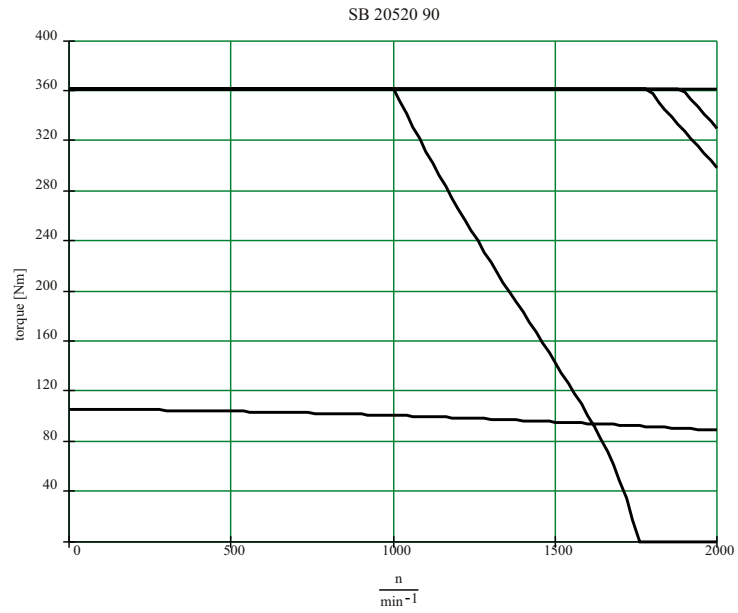



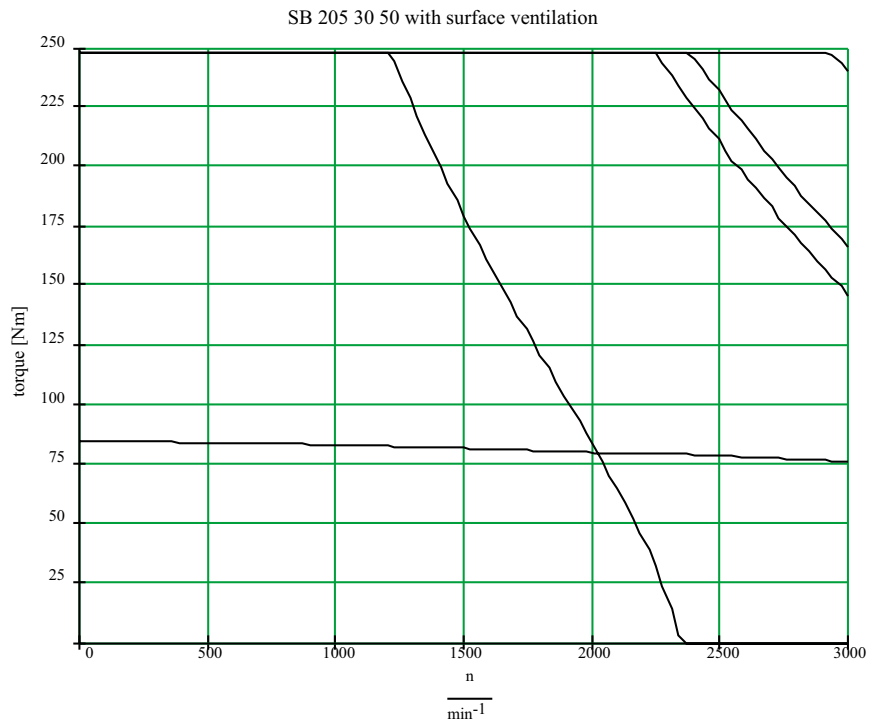
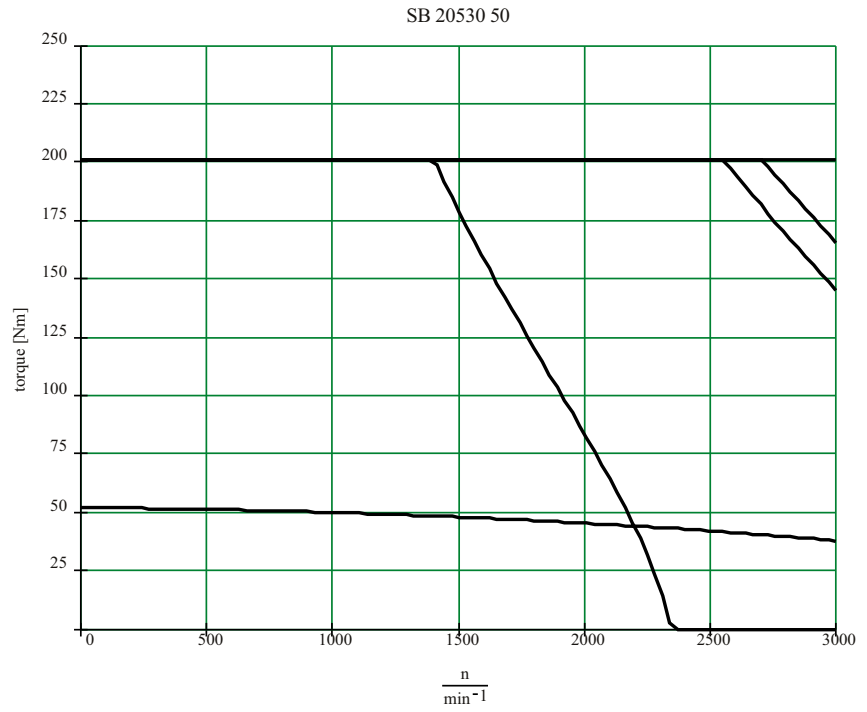

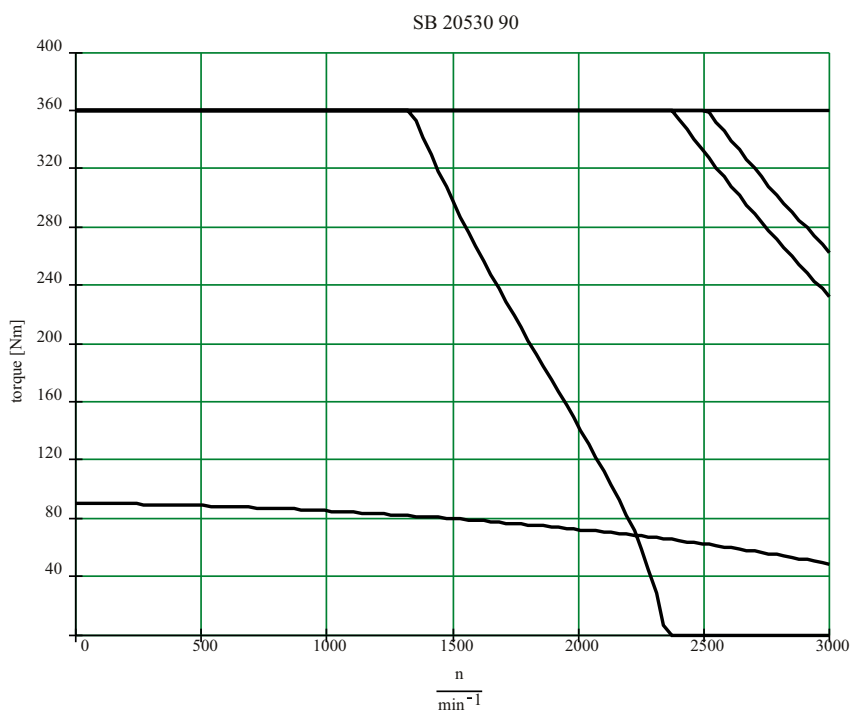
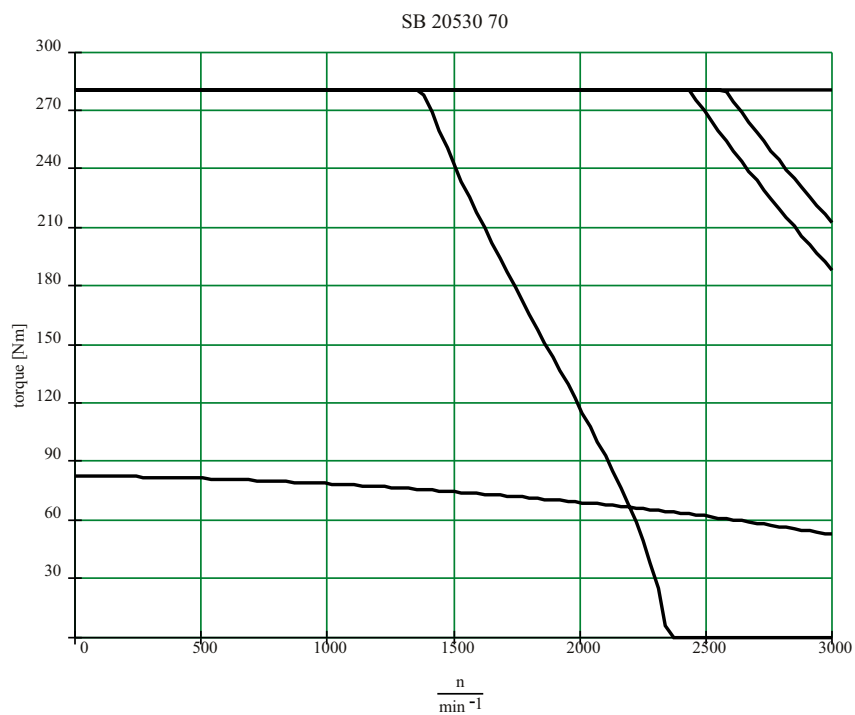

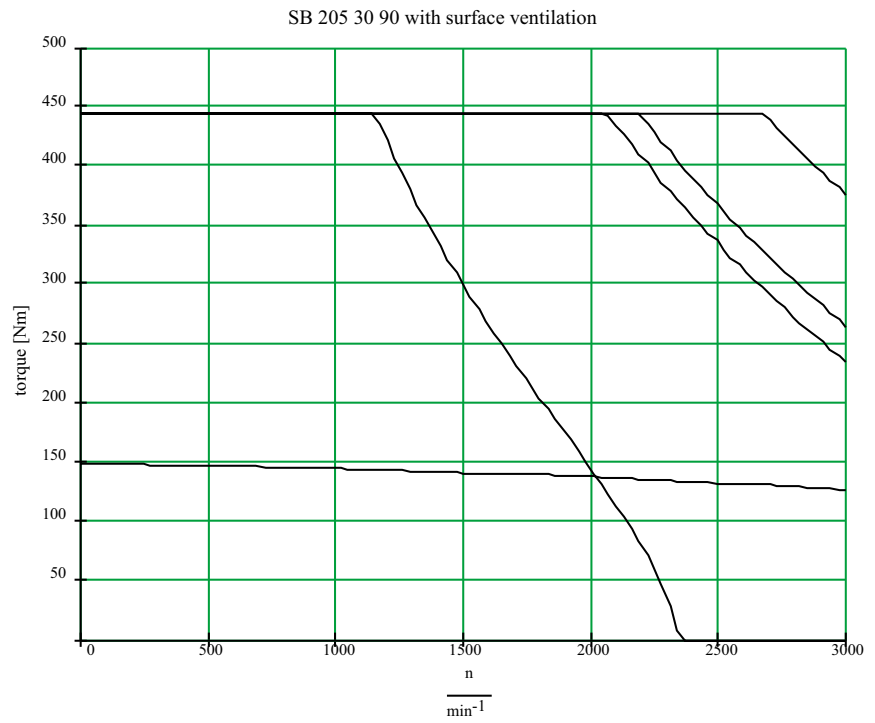

## 7.2 Electrical Connections

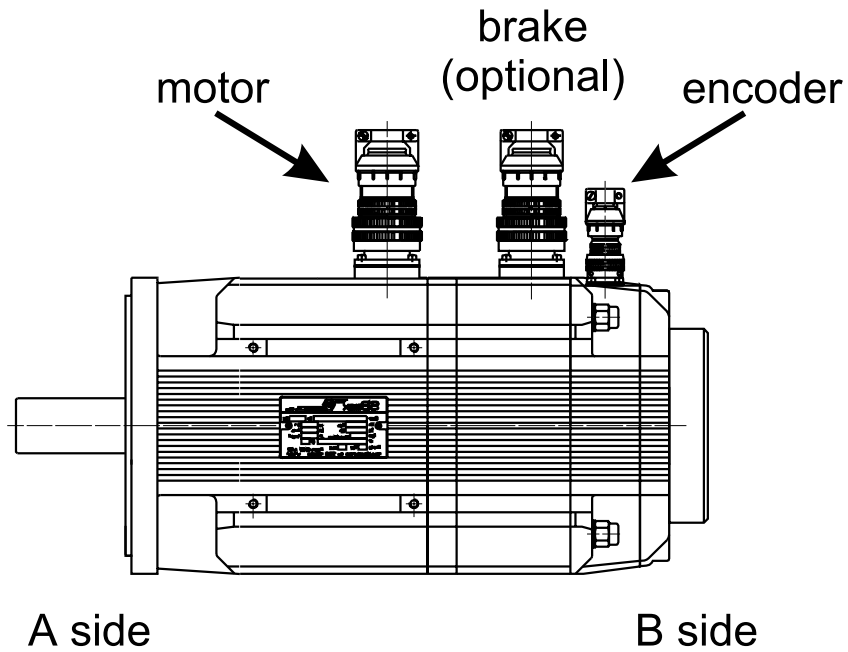

Fig. 7-6: Overview of connections with SB Motor - 1

The SB Motors with higher standstill current come with a connection box for the motor connection.

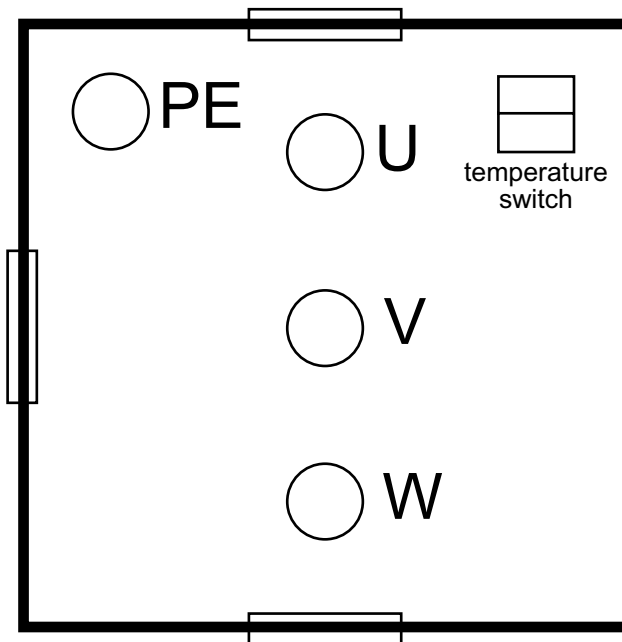

Fig. 7-7: Overview of connections with SB Motor - 2 (connection box)

**Motor (MIL pin)**

Pin	Designation	Meaning	Range	Max. cross section
A	U		3 AC 0 - 480 V	4 mm <sup>2</sup>
B	V		3 AC 0 - 480 V	4 mm <sup>2</sup>
C	W		3 AC 0 - 480 V	4 mm <sup>2</sup>
D	PE	motor earth conductor		4 mm <sup>2</sup>
E	Mθ1	motor temperature		1.5 mm <sup>2</sup>
F	Mθ2	motor temperature		1.5 mm <sup>2</sup>
G	-	reserved		
	connector casing	cable shielding		

Table 7-21: Motor connection of SB Motor (MIL pin)

**Motor (connection box)**

Pin	Designation	Meaning	Range	Max. cross section
	U		3 AC 0 - 480 V	10 mm <sup>2</sup>
	V		3 AC 0 - 480 V	10 mm <sup>2</sup>
	W		3 AC 0 - 480 V	10 mm <sup>2</sup>
	PE	motor earth conductor		10 mm <sup>2</sup>
	Mθ1	motor temperature		1.5 mm <sup>2</sup>
	Mθ2	motor temperature		1.5 mm <sup>2</sup>

Table 7-22: Motor connection of SB Motor (connection box)

**Brake (MIL pin)**

Pin	Designation (lead no.)	Meaning	Range	Max. cross section
A	br+ (8)	holding brake	DC 24 V	1.5 mm <sup>2</sup>
B	br- (7)	holding brake	DC 0 V	1.5 mm <sup>2</sup>
C	-	reserved		
	connector casing	cable shielding		

Table 7-23: Brake connection of SB Motor

**NOTE**

A varistor is integrated between br+ and br-.

**SinCos encoder (MIL pin)**

Pin	Designation	Meaning	Range	Max. cross section
A	-	reserved		
B	GND	supply voltage	DC 0 V	0.25 mm <sup>2</sup>
C	REFCOS	cosine reference signal		0.25 mm <sup>2</sup>
D	COS	cosine trace		0.25 mm <sup>2</sup>
E	REFSIN	sinus reference signal		0.25 mm <sup>2</sup>
F	SIN	sinus trace		0.25 mm <sup>2</sup>
G	-	reserved		
H	Us	supply voltage	DC 7 - 12 V	0.25 mm <sup>2</sup>
J	RS485-	parameter channel -		0.25 mm <sup>2</sup>
K	RS485+	parameter channel +		0.25 mm <sup>2</sup>
	connector casing	cable shielding		

Table 7-24: Encoder connection of SB Motor (SinCos encoder)

## 7.3 Dimensions

### 7.3.1 SB-Motor

#### SB 056

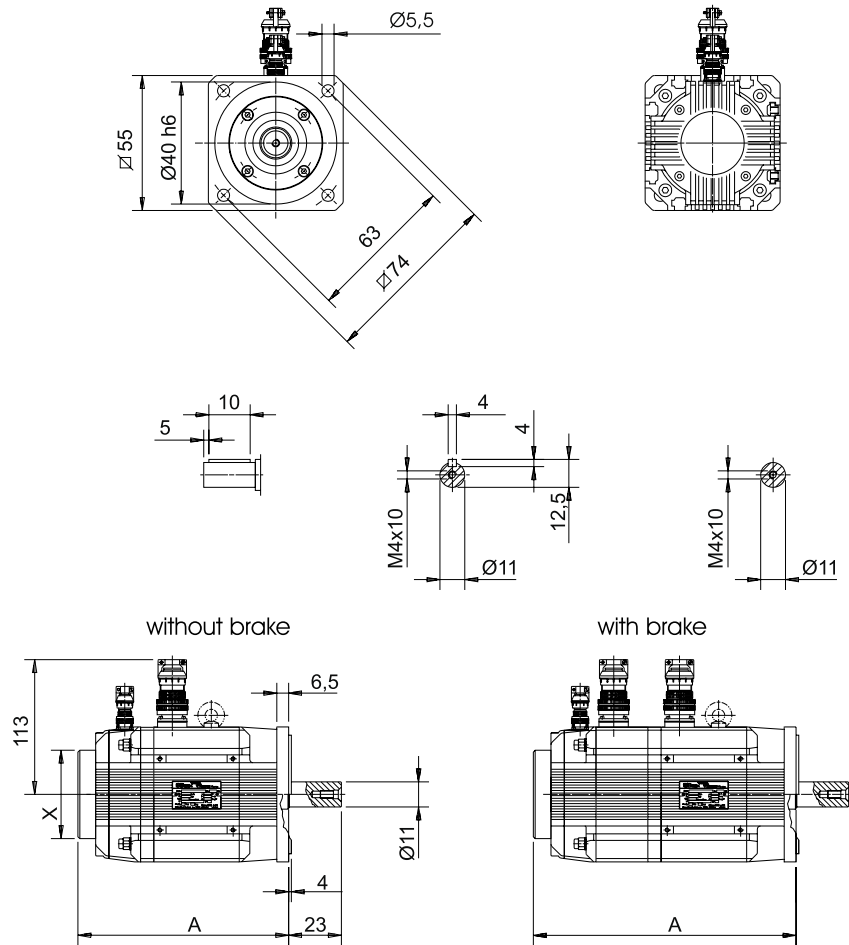

Fig. 7-8: Dimensional drawing of SB 056

Dimensions	xx 06
A	170,5

Table 7-25: Dimensions of SB 056 without brake

Dimensions	xx 06
A	221,5

Table 7-26: Dimensions of SB 056 with brake

#### Tolerances:

Shaft diameter: k6  
featherkey way according to DIN 6885, tight fit, tolerance P9

**SB 070**

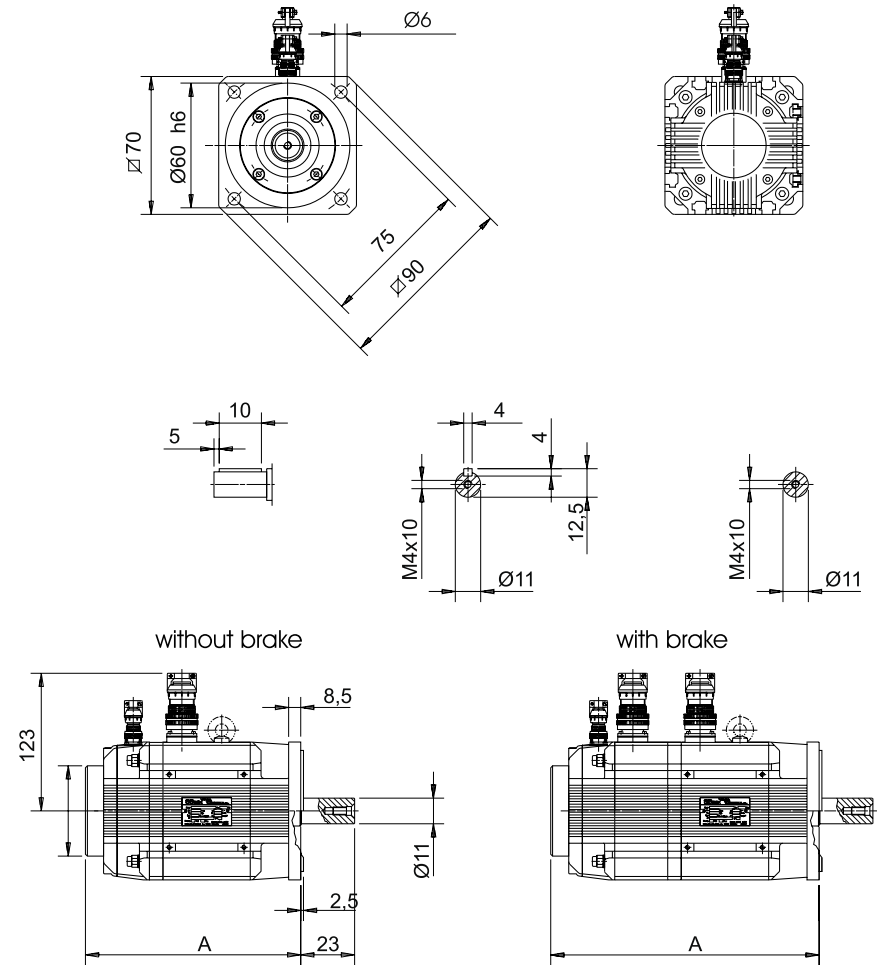

Fig. 7-9: Dimensional drawing of SB 070

Dimensions	xx 05	xx 10	xx 15	xx 20
A	158	188	218	248

Table 7-27: Dimensions of SB 070 without brake

Dimensions	xx 05	xx 10	xx 15	xx 20
A	214	244	274	304

Table 7-28: Dimensions of SB 070 with brake

Tolerances:

Shaft diameter: k6  
featherkey way according to DIN 6885, tight fit, tolerance P9



**SB 105**

Fig. 7-10: Dimensional drawing of SB 105

Dimensions	xx 02	xx 04	xx 06	xx 08
A (A mit SinCos)	186 (205)	229 (248)	273 (292)	317 (336)

Table 7-29: Dimensions of SB 105 without brake

Dimensions	xx 02	xx 04	xx 06	xx 08
A (A mit SinCos)	250 (269)	293 (312)	337 (356)	381 (400)

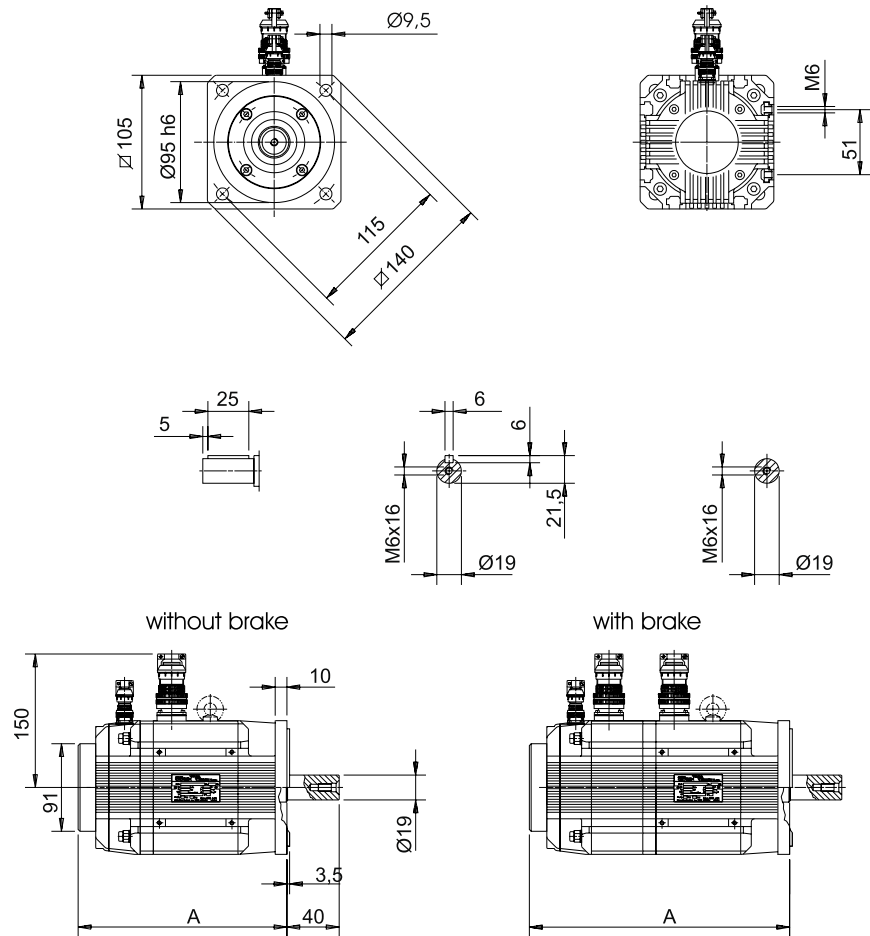
Table 7-30: Dimensions of SB 105 with brake

**Tolerances:**

Shaft diameter: k6

featherkey way according to DIN 6885, tight fit, tolerance P9

**SB 145**

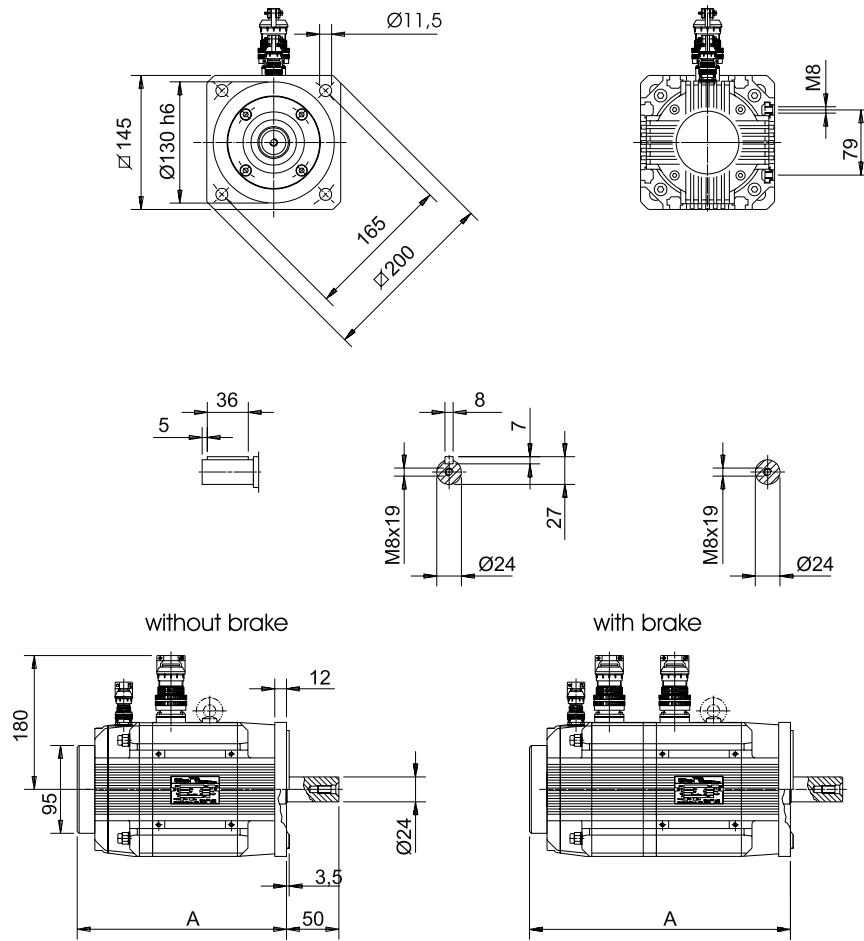

Fig. 7-11: Dimensional drawing of SB 145

Dimensions	xx 08	xx 15	xx 22	xx 28
A (A mit SinCos)	231 (250)	292 (311)	354 (373)	416 (435)

Table 7-31: Dimensions of SB 145 without brake

Dimensions	xx 08	xx 15	xx 22	xx 28
A (A mit SinCos)	305 (379)	366 (440)	428 (502)	490 (564)

Table 7-32: Dimensions of SB 145 with brake

Tolerances:

Shaft diameter: k6

featherkey way according to DIN 6885, tight fit, tolerance P9

**SB 205**

Fig. 7-12: Dimensional drawing of SB 205

Dimensions	xx 27	xx 50	xx 70	xx 90
A (A mit SinCos)	273 (292)	342 (361)	411 (430)	480 (499)

Table 7-33: Dimensions of SB 205 without brake

Dimensions	xx 27	xx 50	xx 70	xx 90
A (A mit SinCos)	372 (391)	441 (460)	510 (529)	579 (598)

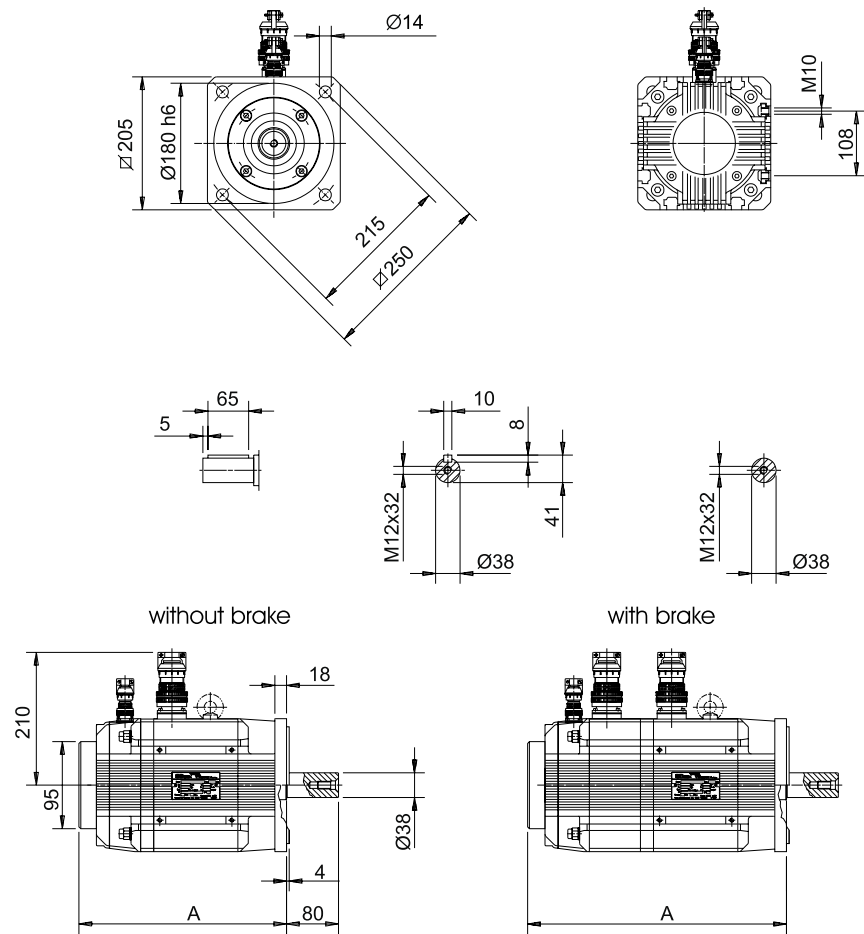
Table 7-34: Dimensions of SB 205 with brake

**Tolerances:**

Shaft diameter: k6

featherkey way according to DIN 6885, tight fit, tolerance P9

### SB Motor with surface ventilation

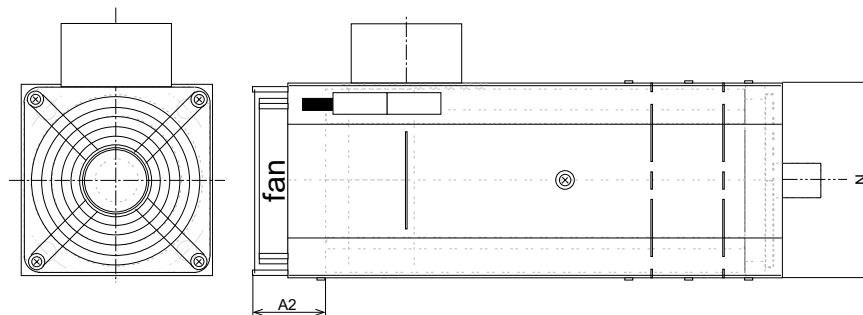

Fig. 7-13: Dimensional drawing of SB Motor with surface ventilation

If an SB motor has surface ventilation, the motor gets longer. Add the size A2 to the size A of the „standard motor“.

SB Motor	Size A2	Size N
SB 056	not with fan available	not with fan available
SB 070	approx. 59 mm (2.32)	approx. 110 mm (4.33)
SB 105	approx. 69 mm (2.72)	approx. 145 mm (5.71)
SB 145	approx. 75 mm (2.95)	approx. 170 mm (6.69)
SB 205	approx. 105 mm (4.13)	approx. 235 mm (9.25)

Table 7-35: Dimensions of SB Motor with surface ventilation

7.3.2 SP Gearbox

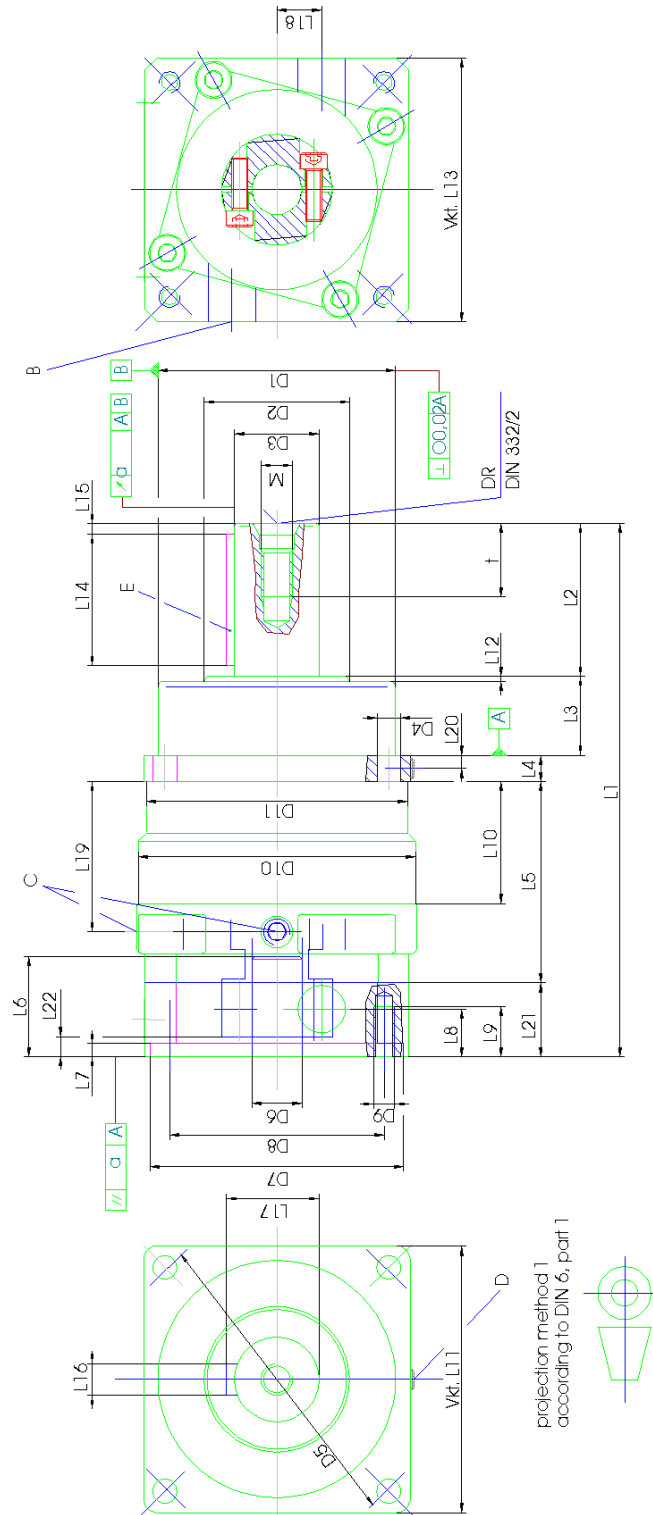

Fig. 7-14: Dimensional drawing of SP gearbox

### Sizes SP 060 and SP 075

Size		SP 060		SP 075	
Number of gears		1	2	1	2
D1	g6	60	60	70	70
D2		30	30	38	38
D3	k6	16	16	22	22
D4	4x	5.5	5.5	6.6	6.6
D5		68	68	85	85
D6	F7	14	14	19	19
D10		58.5	58.5	74	74
L1	+/- 2	129	149	156	182.5
L2		28	28	36	36
L3		20	20	20	20
L4		6	6	7	7
L5		60	80	71	97.5
L6	min. max.	15 30	15 30	23 40	23 40
L7	+0.5	4	4	4	4
L8		9.4	9.4	14	14
L9		9	9	12	12
L10		44	64	51	77.5
L11	+/- 1	62	62	76	76
L12		2	2	2	2
L13	+/- 1	60	60	80	80
L14*		25	25	32	32
L15		2	2	2	2
L16	h9	5	5	6	6
L17		18	18	24.5	24.5
L18**		10	10	12	12
L19		48.3	68.3	57	83.5
L20		-	-	-	-
a		0.025	0.025	0.025	0.025
B		8	8	15	15

Size		SP 060		SP 075	
C		1xM6	1xM6	1xM8x1	1xM8x1
D		-		-	
E		feather groove according to DIN 6885 sheet 1, form A			
M		M5	M5	M8	M8
t		12.5	12.5	19	19

Table 7-36: Gearbox dimensions

\* (on L14) In case of reversing operation and high gear strain, we recommend smooth drive shafts.

\*\* (on L18) The dimensions may differ in case of very small motors.

### Sizes SP 100, SP 140 and SP 180

Size		SP 100		SP 140		SP 180	
Number of gears		1	2	1	2	1	2
D1	g6	90	90	130	130	160	160
D2		55	55	70	70	90	90
D3	k6	32	32	40	40	55	55
D4	4x	9	9	11	11	13	13
D5		120	120	165	165	215	215
D6	F7	28	28	35	35	48	48
D10		99	99	124	124	180	180
L1	+/- 2	202	234.5	256.5	296.5	297	315.5
L2		58	58	82	82	82	82
L3		30	30	30	30	30	30
L4		10	10	12	12	15	15
L5		76	108.5	102	142	132.5	158
L6	min. max.	30 50	30 50	32 60	32 60	45 82	45 82
L7	+0.5	5	5	6	6	6	6
L8		18	18	18	18	24.5	18
L9		19	19	21	21	25	21
L10		50	82.5	66.5	106.5	84.5	122.5
L11	+/- 1	101	101	141	141	182	182
L12		2	2	3	3	3	3
L13	+/- 1	100	100	140	140	190	140
L14*		50	50	70	70	70	70
L15		4	4	5	5	6	6
L16	h9	10	10	12	12	16	16
L17		35	35	43	43	59	59
L18**		17	17	19	19	26	19
L19		57	89.5	74.5	114.5	100.5	130.5
L20		5	5	6	6	12	12
L21		28	28	30.5	30.5	37.5	30.5
a		0.025	0.025	0.04	0.04	0.04	0.04



Size		SP 100		SP 140		SP 180	
B		18	18	20	20	20	20
C		3xM12x1.5		3xM12x1.5		3xM12x1.5	
D		1xM8x1		1xM8x1		1xM8x1	
E		feather groove according to DIN 6885 sheet 1, form A					
M		M12	M12	M16	M16	M20	M20
t		28	28	36	36	42	42

Table 7-37: Gearbox dimensions

\* (on L14) In case of reversing operation and high gear strain, we recommend smooth drive shafts.

\*\* (on L18) The dimensions may differ in case of very small motors.



## 8 Appendix

---

### 8.1 Contact Addresses

---

#### For repair

Please send the components to be repaired or checked, along with the error report, to this address:

#### ELAU AG

Abt. Kundendienst	house address:
Postfach 1255	Dillberg 12
97821 Marktheidenfeld	97828 Marktheidenfeld
Phone: +49 (0) 93 91 / 606 - 142	
Fax: +49 (0) 93 91 / 606 - 300	

#### Service team

Should you need to talk to a member of our service team or require on-site service, please contact:

#### ELAU AG

Dillberg 12  
 D-97828 Marktheidenfeld  
 Phone: +49 (0) 93 91 / 606 - 0  
 Fax: +49 (0) 93 91 / 606 - 300  
 e-mail: info@elau.de  
 Internet: www.elau.de

#### ELAU, Inc.

4201 West Wrightwood Avenue  
 Chicago, Illinois 60639 - USA  
 Phone: +1 773 342 8400  
 Fax: +1 773 342 8404  
 e-mail: sales@elau.com  
 Internet: www.elau.com

#### ELAU SYSTEMS ITALIA S.r.l.

Via Tosarelli 300  
 I-40050 Villanova di Castenaso (BO)  
 Phone: +39 051 / 7818 70  
 Fax: +39 051 / 7818 69  
 e-mail: info@elau.it  
 Internet: www.elau.it

---

#### NOTE

You find more contact addresses on the ELAU homepage ([www.elau.de](http://www.elau.de)).

---



## 8.2 Further Literature

ELAU can provide you with these manuals and instructions on the PacDrive™ systems:

### Project Manual PacDrive M

German	Art.No. 17 13 00 58 - 000
English	Art.No. 17 13 00 58 - 001
French	Art.No. 17 13 00 58 - 003

### Operating Manual MC-4 MotorController (PacDrive M)

German	Art.No. 17 13 00 62 - 000
English	Art.No. 17 13 00 62 - 001
Italian	Art.No. 17 13 00 62 - 002
French	Art.No. 17 13 00 58 - 003

### Project Manual PacDrive S

German	Art.No. 17 13 00 55 - 000
English	Art.No. 17 13 00 55 - 001

### Operating Manual PacDrive S

German	Art.No. 17 13 00 54 - 000
English	Art.No. 17 13 00 54 - 001
Italian	Art.No. 17 13 00 54 - 002
French	Art.No. 17 13 00 54 - 003
Spain	Art.No. 17 13 00 54 - 004

### Operating Manual SB-Motor

German	Art.No. 17 13 00 51 - 100
English	Art.No. 17 13 00 52 - 100

### Operating Manual SM-Motor

German	Art.No. 17 13 00 68 - 000
English	Art.No. 17 13 00 68 - 001
Italian	Art.No. 17 13 00 68 - 002
French	Art.No. 17 13 00 68 - 003

### Operating Manual SR-Motor

German	Art.No. 17 13 00 82 - 000
English	Art.No. 17 13 00 82 - 001

## **8.3 Product Training**

---

We offer practical workshops and seminars in our training centre in Marktheidenfeld.

Our experienced seminar leaders will enable you to make optimum use of the vast possibilities of the PacDrive™ M system.

Please contact us for further information or to order our seminar program. See also our homepage ([www.elau.de](http://www.elau.de)).

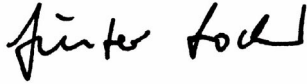

## 8.4 Declaration by the manufacturer

	<p style="text-align: center;"><b>Herstellereklärung / EC-Declaration by the manufacturer / CE-Déclaration du fabricant</b></p> <p style="text-align: center;">im Sinne der EG-Maschinenrichtlinie 89/392 EWG, Anhang II Abschnitt B as defined by EC-machinery directive 89/392 EEC, Annexe II Section B conformément à la directive "CE" relative aux machines 89/392 CEE Annexe II Section B</p>	<p style="text-align: center;"><b>ELN 120-01/09.01</b></p> <p style="text-align: center;">Seite 1/1</p>
<p>Das von uns gelieferte Produkt</p> <p><b>AC-Servomotor</b></p> <p><b>SR 058</b></p> <p>ist zum Einbau in eine Maschine bestimmt.</p> <p>Die Inbetriebnahme ist solange untersagt, bis festgestellt wurde, dass die Maschine, in die dieses Produkt eingebaut werden soll, den Bestimmungen der EG-Richtlinie entspricht.</p> <p><b>Hersteller:</b></p> <p>ELAU AG Dillberg 12 D-97828 Marktheidenfeld</p> <p><b>Stellung im Betrieb / Position :</b></p> <p>Vorstand/Chairman</p>  <p>3.9.2001 Günter Locherer ..... (Datum, Date / Unterschrift, Signature)</p>	<p>The product delivered by our company</p> <p><b>AC-Servomotor</b></p> <p><b>SR 058</b></p> <p>is intended to be incorporated into a machine.</p> <p>The product must not be operated until the machine into which this product is to be incorporated has been declared in conformity with the provisions of the directive.</p> <p><b>Manufacturer:</b></p> <p>ELAU AG Dillberg 12 D-97828 Marktheidenfeld</p>	<p>Le produit livré par notre société</p> <p><b>AC-Servomotor</b></p> <p><b>SR 058</b></p> <p>est destiné à être installé dans une machine.</p> <p>La mise en service des composants est fortement déconseillée avant que la machine dans laquelle le produit sera installé n'ait été déclarée conforme aux dispositions de la directive.</p> <p><b>Fabricant:</b></p> <p>ELAU AG Dillberg 12 D-97828 Marktheidenfeld</p>

---

## 8.5 Modifications

### 07 / 1998

- Operating Manual newly written

### 01 / 1999

- Allocation in operating manual SB motor and SM motor
- various expansions

### 10 / 2001

- structure of the document revised
- engines with fan new
- order numbers updated
- description of the encoder systems new
- description of the holding brake expanded
- various error corrections and supplements



### NOTE

The latest documentation and modification service on this product are available on the ELAU Homepage ([www.elau.de](http://www.elau.de)).

---



## 8.6 Index

### A

admissible shaft strain 54  
 ambient conditions  
   SB motor 52  
 approvals  
   SB motor 52

### B

bearing  
   SB motor 53  
 brake 16, 101  
   SB motor 57

### C

CE 119  
 characteristics  
   SB motor 72  
 cleaning 25  
 commissioning 28  
 configuration 29  
 connections  
   SB motor 100  
 contents III

### D

declaration by the manufacturer 119  
 definitions 47  
 depiction conventions 13  
 diagnosis 17  
 dimensions  
   gearbox 109  
   SB motor 103

### E

ELAU AG 2  
 eMail  
   ELAU AG 2  
 EMC rules 25  
 encoder 16  
   resolver 56  
   SinCos (motor) 55  
 error report 123  
 exchanging units 23  
   cable 24

### F

features 15  
 feedback 16

### H

holding brake 16  
   SB motor 57  
 homepage  
   ELAU AG 2

### I

imprint 2  
 internet  
   ELAU AG 2

### L

literature 116

### M

maintenance 21  
 manuals 116  
 modifications 120  
 motor 101  
   -feedback 16  
   -shaft (SB motor) 53

### O

operating manual 116  
 order numbers  
   cables 45  
   SB motor 30  
 overview 15

### P

physical correlations 47  
 pictograph 5  
 programming 29  
 protection means  
   SB motor 52

### Q

qualification of personnel  
   safety 13

### R

repair 22, 115

- risk
  - classification 5
  
- S**
- safety 7
  - notes 5
- sales regions 115
- seminare 117
- service
  - personnel 115
- service addresses 22
- shaft
  - SB motor 53
- SinCos 102
- spare parts 21
- storage 19
- surface ventilation
  - SB motor 59
  
- T**
- technical data
  - SB 056 50 60
  - SB 070 40 61
  - SB 070 60 62
  - SB 105 20 63
  - SB 105 30 64
  - SB 105 40 65
  - SB 145 20 66
  - SB 145 30 67
  - SB 145 40 68
  - SB 205 10 69
  - SB 205 20 70
  - SB 205 30 71
- trademarks 2
- training 117
- transportation 19
- type plate 20
  
- U**
- unpacking 20
  
- W**
- warning notes 5

## 8.7 Form for Error Report

This error report is absolutely necessary in order to enable efficient processing.

Send the error report to your ELAU representative or to:

ELAU AG, Abt. Kundendienst  
 Dillberg 12, D-97828 Marktheidenfeld  
**Fax: 09391/606-300**

Sender:

Company:	City:	Date:
Department:	Name:	Tel.:

### Details on the defective product

Product name: .....

Article number: .....

Serial number: .....

Software version: .....

Hardware code: .....

Parameter enclosed:        yes [ ]    no [ ]

IEC program enclosed:        yes [ ]    no [ ]

### Details of the machine on which the problem occurred:

Machine producer: .....

Type: .....

Hours of operation: .....

Machine number: .....

Date of commissioning: .....

Producer/Type of machine control:

.....

